



Reciprocating Grate
Combustion System

**MORE MODELS
CHOICES
SOLUTIONS**

- (1) "FIREBOX" Firetube/Watertube Vessel Design
- (2) Ash Collector
- (3) Induced Draft fan/stack
- (4) Reciprocating Fire Grates
- (5) Under Fire Air Fan
- (6) Reciprocating Drive
- (7) Over Fire Fan/Dampers
- (8) Rotary Ash Dump to Can
- (9) Fire Door
- (10) Aux. Ash Clean Out Door
- (11) Watertube Section
- (12) Fuel Metering Bin
- (13) Ash Removal Conveyor
- (14) Refractory Arch
- (15) Walking Floor Fuel Storage
- (16) Transfer Conveyor
- (17) Over Sized Fuel Material for re-Chipping Bin

- Efficient 3-Pass Design.
- Water "Leg" Side Walls (High Efficiency Tubed Membrane)
- Wet-Back Construction.
- A.S.M.E. Code Constructed & Stamped.
- Registered with National Board of Inspectors.
- Large Water Cooled Furnace.
- Burner Mounting Ring.
- 16" Rear Access Port.
- Ample Water-Side Clean-out Opening.
- 2" High Temp Insulation.
- Powder Coat Finish on Lagging.
- UL Listed Controls & Trim.
- Open Bottom for Stoker Firing of Solid Fuel.
- Hinged Front & Rear Doors.

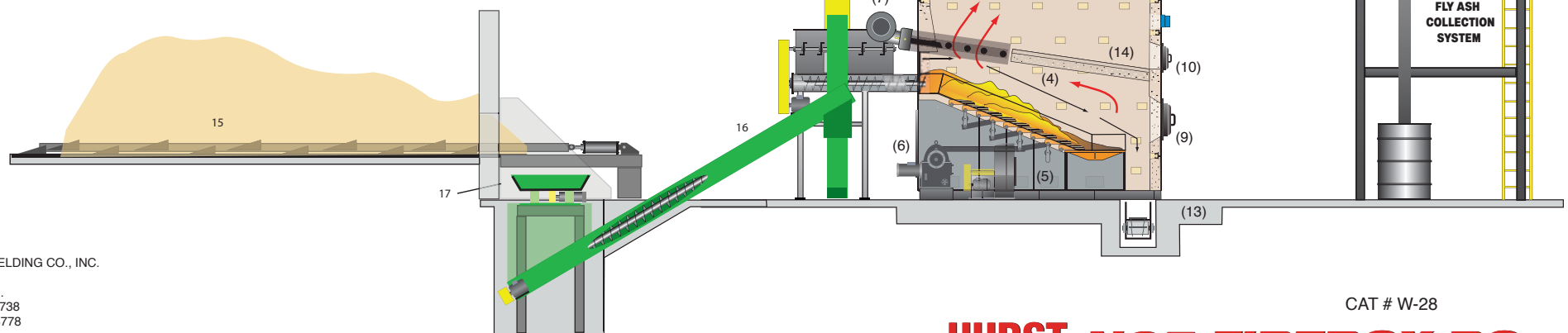

HURST BOILER & WELDING CO., INC.
P. O. Drawer 530
21971 Highway 319 N.
Coolidge, Georgia 31738
Toll Free: 1-877-994-8778
Tel: (229) 346-3545
Fax: (229) 346-3874
Email: info@hurstboiler.com

CAT # W-28

HURST N65 FIREBOX RG

Reciprocating Grate System

Modular Packaged