

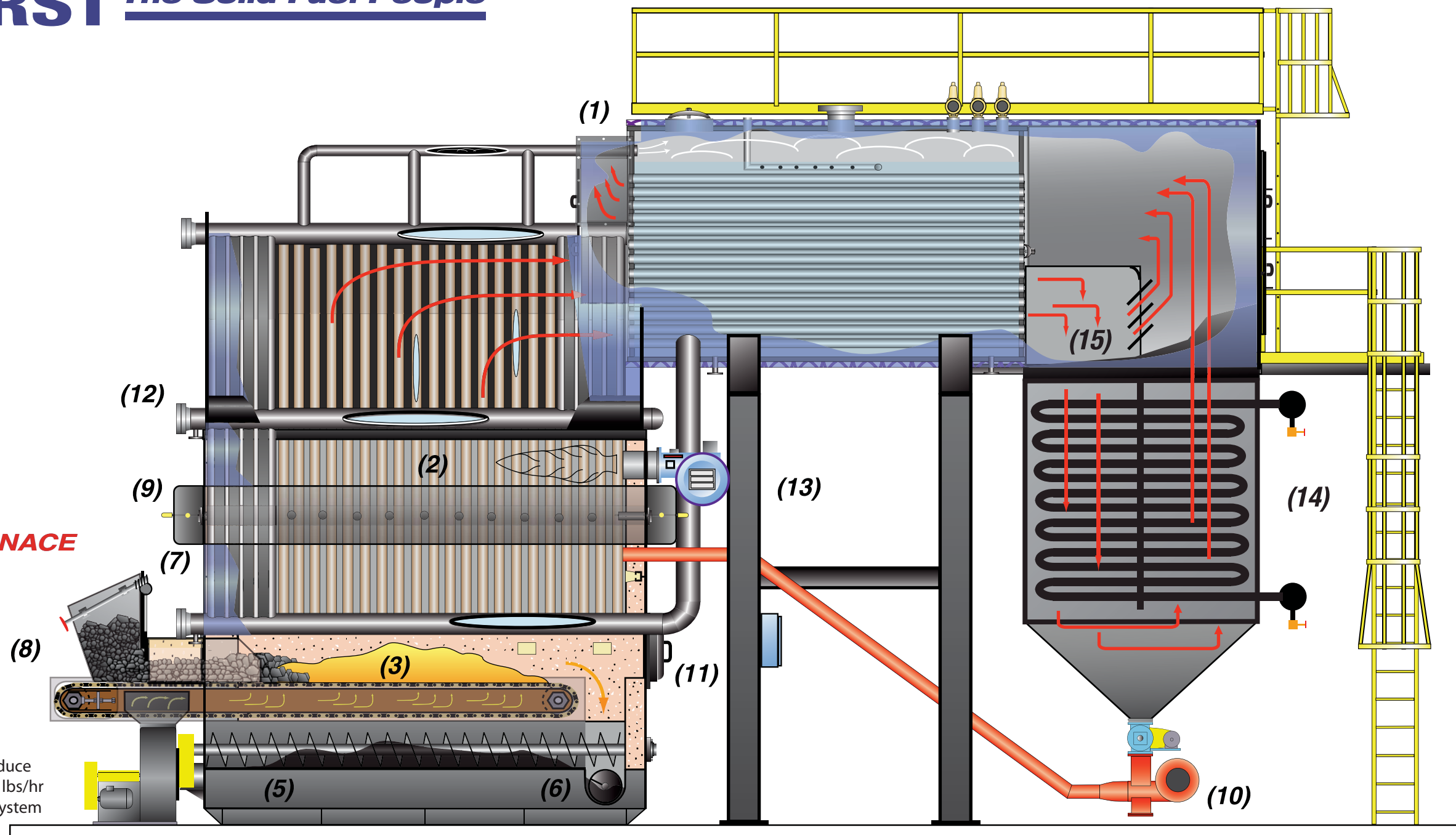

HURST *The Solid Fuel People*

- (1) "Hybrid" Firetube/Watertube Vessel Design
- (2) Watertube Section
- (3) Chain Grate Stoker System
- (4) Combustion Chamber
- (5) Primary Ash Collection Screw
- (6) Secondary Ash Removal Screw
- (7) Air Control Dampers
- (8) Metering Hopper
- (9) Over Fire Air System
- (10) Ash Reinjection Blower
- (11) Fire Doors
- (12) Water-Side Inspection Ports
- (13) Backup Gas/Oil Burner
- (14) Super Heater (heat exchanger)
- (15) Flue Gas Diverter (bypass damper)

WATER WALL FURNACE



The Hybrid WW CG SH design is suitable for applications to produce high pressure steam or hot water in ranges from 3,450 – 60,000 lbs/hr (3.4 mmBTU – 60 mmBTU) output from 100 up to 400 PSI. This system is designed by HBC to combine the best technologies from the "old school" of coal combustion and the latest advanced

combustion control technologies. The new HBC chain grate-type stoker system permits either bituminous coal washed singles or smalls to be combusted in an efficient manner with the added advantage of automatic de-ashing. This combination is particularly suitable for industrial heating and process steam applications. The boiler vessel is a two pass hybrid design incorporating a water tubed boiler-type water membrane and a two-pass fire tube scotch marine vessel. This vessel's advantages over standard water tube boilers include much larger steam disengagement area providing high quality steam, larger steam storage capability for quicker response to sudden steam demand and much larger thermal storage that provides fast demand response times and safer operation. This system also incorporates extended water wall membranes that extend down the gasification/combustion chambers side walls thereby greatly reducing refractory requirements which is essential when utilizing highly volatile solid fuels.

HURST

HYBRID WW CG SH

COAL FIRED

Modular Packaged

SUPER HEATER *equipped*