



INTERNAL USE ONLY
INFORMATION SUBJECT TO
CHANGE WITHOUT NOTICE

EnergyCell 5

User Manual



OPTICS RE Compatible



About OutBack Power

OutBack Power designs and manufactures advanced battery-based renewable energy systems and power electronics, empowering energy independence for off-grid, grid-tied, and backup applications worldwide.

Applicability

These instructions are only applicable to the OutBack EnergyCell 5 battery system.

Contact Information

Address: 400 Maple St
Commerce, TX 75428 USA

Telephone: +1 360-435-6030

Website: www.outbackpower.com

Warranty

The warranty for this product can be downloaded from: <https://outbackpower.com/procedures/>

Notice of Copyright

© 2025 by Outback Power. All Rights Reserved. Subject to revisions without notice. E. & O.E.

Trademarks

Trademarks and logos are the property of Outback Power and its affiliates unless otherwise noted. The UL, ETL, and IEEE trademarks are not the property of Outback Power.

Date and Revision

October 2025, Revision A

Part Numbers

EC-FE5148, EC-FE5148-CM, EC-FE5148-B

Table of Contents



General Safety	4
Symbols Used in Manual	4
Symbols Used on Equipment	4
Battery Safety Information	5
Introduction	8
Welcome to OutBack Power	8
Components	9
Included in the Box	9
Battery Module Components	10
Control Module Components	11
Dimensions	12
Battery Communication	14
Installation	15
Location and Environmental Requirements	15
Recommended Tools	16
Single Stack Installation and Cabling	17
Design Guidelines	24
One Inverter with 2 Parallel Stacks Diagram	26
One Inverter with 3 Parallel Stacks Diagram	26
Parallel Inverters with Dedicated Stacks Diagram	28
Commissioning	29
Functional Test	29
Pre-Power Up Procedures	29
Power Up	29
Powering Down	30
System Charge	30
Phone App	30
Troubleshooting	32
Common Issues and Solutions	32
LEDs	32
System Maintenance	33
Battery Storage	33
Battery Disposal	33
Specifications	34
Abbreviations	37

INTERNAL USE ONLY
SUBJECT TO
CHANGE WITHOUT NOTICE

General Safety



This manual provides instructions for the physical installation and wiring of this product, along with detailed information on stacked lithium batteries, including specifications, operational guidelines, maintenance procedures, and other relevant details. It is intended for use by professionals and technical personnel who install, operate, and maintain the batteries, as well as end-users.

Symbols Used in Manual

	WARNING: Hazard to Human Life This type of notation indicates that a hazard may pose a risk to human health and safety.
	CAUTION: Hazard to Equipment This type of notation indicates that the hazard could potentially damage the equipment.
	IMPORTANT: This type of notation indicates that the information provided is important for the installation, operation, and/or maintenance of the equipment. Failure to follow the recommendations in such a notation could result in the equipment warranty being voided.
	NOTE: This type of notation indicates useful information. This symbol is not always used.

Symbols Used on Equipment

	WARNING: Read the instructions before installation, operation and maintenance of the system
	WARNING: Read the instructions before installation, operation and maintenance of the system
	WARNING: Hazardous Voltage Circuits

Battery Safety Information

Before starting the installation, thoroughly review all safety instructions and follow them when handling the battery and related equipment. Make sure the installation complies with all applicable national and local standards and regulations. Contact the local Authority Having Jurisdiction (AHJ) and/or utility company to secure the necessary permits and permissions prior to installation.

Failure to follow these warnings and instructions could lead to:

- Injury or death to the installer, operator, or others.
- Damage to the battery or other equipment in the system.

Several safety concerns must be addressed before, during, and after system installation. The instructions provided are intended for the installer and any end-users of this product under normal operating conditions.

1. Do not disassemble the product. If it needs repairs, contact the place of purchase for guidance and proper handling instructions. Failing to repair the module properly may pose a risk of electric shock or fire and will void the warranty.
2. Do not short-circuit DC inputs. Short-circuiting the battery can cause electric shock, fire, severe injury, death, or permanent damage to the unit and connected equipment.
3. Use extreme caution when working with metal tools on or around the battery and other system components. The risk of electrical arcs or short-circuiting can cause severe injury or death, as well as damage to equipment.
4. Beware of high battery current. Ensure all battery breakers are in the open (OFF) position before installing or working on the module. Confirm there is no voltage present using a multimeter to avoid electric shock.
5. Do not make any connections or disconnections to the system while it is in operation. There is a risk of electrical shock when working with energized components that generate power.
6. Ensure the battery bank is properly grounded.
7. Make sure to be well protected using compliant PPE (Personal Protective Equipment) during the installation.
8. Inspect all existing wiring to make sure it meets the appropriate specifications and conditions before installing, operating, or maintaining the system.
9. Before operating, ensure that the battery and system component connections are properly made to prevent damage or injuries caused by improper installation.

Only qualified personnel should work on this product and its system design. Including but not limited to: System Design, Installation, Operation, Settings, Configuration, and Maintenance.

1. Read all instructions before installation. For electrical work, follow all local and national wiring standards, regulations, and the installation instructions in the user manual. All wiring should be in accordance with the National Electric Code (NEC), ANSI/NFPA 70.
2. The battery and its system can connect to the utility only if the utility provider permits. Consult with the local AHJ before installing this product for additional requirements and regulations.
3. All labels, nameplates, and warnings on the battery should be clearly visible and must not be removed or covered.
4. Consider the safety of future users when choosing the battery's installation location per the user manual instructions.
5. Do not allow children to be near the battery and/or its system.



**TAKE THESE ADDITIONAL PRECAUTIONS DURING
INSTALLATION/REPLACEMENT**

Important Safety Instructions

Ensure that all precautions listed above have been taken prior to beginning the installation and observe these additional precautions during installation. Failure to take these precautions may result in serious injury or death:



- **Thermal Runaway:** Immediately stop the installation, place battery in a safe state if possible, and move away from the battery if the battery:
 - begins to swell or bulge,
 - if you smell any unusual odors,
 - if you hear a hissing sound, or
 - if the battery begins to emit heat and/or smoke.

Your battery may be experiencing thermal runaway, a dangerous condition that may cause fire or explosion. Contact local fire department, Chemtrec 800-262-8200, and OutBack Power support.

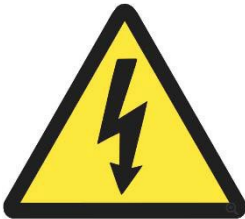

- **Electrical Shock:** When installing/replacing the battery:
 - Ensure that the battery does not get wet.
 - Do not spray water or other liquids on the battery.
 - Do not perform the installation in conditions where dust, moisture, or other debris could enter the battery.
 - Avoid touching connections and components unless instructed to do so by this guide.
 - Do not leave the battery unattended during installation without verifying it is in a safe and secure condition. Do not touch, lean on, or lay tools on the battery or connections.

If you are electrically shocked during installation, place battery in a safe state if possible, and seek immediate medical attention.



- **Ventilation Warning:** When installing/replacing the battery:
 - Do not open the battery.
 - Do not attempt the installation/replacement if the battery is damaged.

Lithium batteries may emit toxic gases when ruptured. Do not attempt to repair battery in the case of rupture. Move outdoors in the case of rupture and seek professional assistance.



- **Electrolyte Exposure: When installing/replacing the battery:**
 - **Ensure that the battery is not damaged.**
 - **Do not attempt the installation/replacement if the battery is damaged.**

Lithium batteries contain a liquid electrolyte solution that is corrosive and damaging to skin and eyes. Exposure may occur in the case of damage to the battery.

General Advice:

In all cases of exposure, seek medical attention if symptoms persist or if large amounts of electrolyte are involved. Show this safety information to the treating physician.

Skin Contact:

- **Immediately remove contaminated clothing and shoes.**
- **Rinse affected skin thoroughly with plenty of water for at least 15 minutes.**
- **Seek medical attention if irritation persists or burns appear.**
- **Wash contaminated clothing before reuse.**

Eye Contact:

- **Immediately flush eyes with plenty of water for at least 15 minutes, keeping eyelids open.**
- **Remove contact lenses if present and easy to do.**
- **Seek immediate medical attention.**

Inhalation (if applicable):

- **Move the person to fresh air immediately.**
- **If breathing is difficult, provide oxygen. If not breathing, give artificial respiration.**
- **Seek immediate medical attention.**

Ingestion:

- **Do not induce vomiting.**
- **Rinse mouth with water.**
- **Give small amounts of water or milk to dilute, if the person is conscious and alert.**
- **Never give anything by mouth to an unconscious person.**
- **Seek immediate medical attention or contact Poison Control immediately.**



Introduction

Welcome to OutBack Power

The OutBack EnergyCell 5 is an all-weather, low-voltage, stackable battery built for energy storage applications, with a modular design, independent protection, and active balancing.

- Equipped with high-performance lithium iron phosphate cells for longevity, safety, and a broad operating temperature range
- Lightweight and compact for a high-density, pollution-free energy product
- Integrated active balancing BMS with management of battery voltage, current, temperature, and health
- LED lights to indicate battery SOC
- Automatic Recognition Protocols - Enable faster and easier closed-loop communication with supported inverters
- RS485/CAN Communication
- Automatic Identification and Addressing - Easily add and identify multiple EnergyCell 5 stackable batteries
- Supports the parallel connection of multiple batteries and stacks of batteries
- Fire prevention feature with an integrated fire extinguishing module
- Stable performance and maintenance-free
- Over 10 years of design life



Components

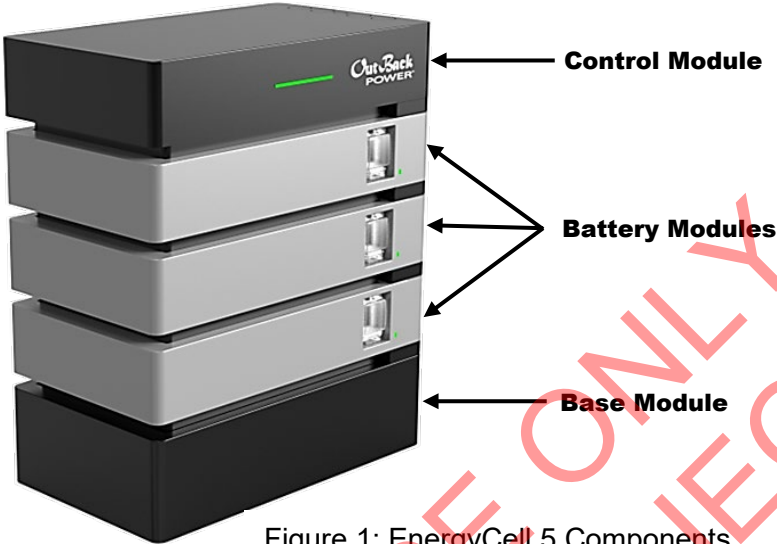

Figure 1: EnergyCell 5 Components

Included in the Box

Control Module & Base Module	Battery Module
Control Module *	Battery Module
Base Module	Communication Cable - Battery to Battery 8 5/8 in. [220 mm]
Communication Cable - Control Module to Inverter 59 in. [1500 mm]	Red Power Cable - Battery (Degson) to Battery (Degson), 2 AWG, 6 1/4 in. [160 mm]
Communications Cable Waterproof Cover (x2) **	Black Power Cable - Battery (Degson) to Battery (Degson), 2 AWG, 6 1/4 in. [160 mm]
Red Power Cable – Control Module (Degson) to Inverter (bare), 2/0 AWG, 59 in. [1500 mm]	Emergency Shutdown DI Connector & Wire - 59 in. [1500 mm]
Black Power Cable – Control Module (Degson) to Inverter (bare), 2/0 AWG, 59 in. [1500 mm]	120 Ω RJ45 Terminating Resistor
Red Power Cable – Control Module (Degson) to Battery (Degson), 2 AWG, 60 in. [1524 mm]	Chassis Connector - Battery to Battery
Black Power Cable – Control Module (Degson) to Battery (Degson), 2 AWG, 60 in. [1524 mm]	L-Brackets (x2)
Chassis Connector – Control Module to Battery Module	
Chassis Connector – Base Module to Battery Module	
Wi-Fi Antenna	
L-Brackets (x2)	

* Ships in a separate box from the Base Module and included accessories.
 ** Used when attaching a communication cable between parallel battery stacks.

Battery Module Components

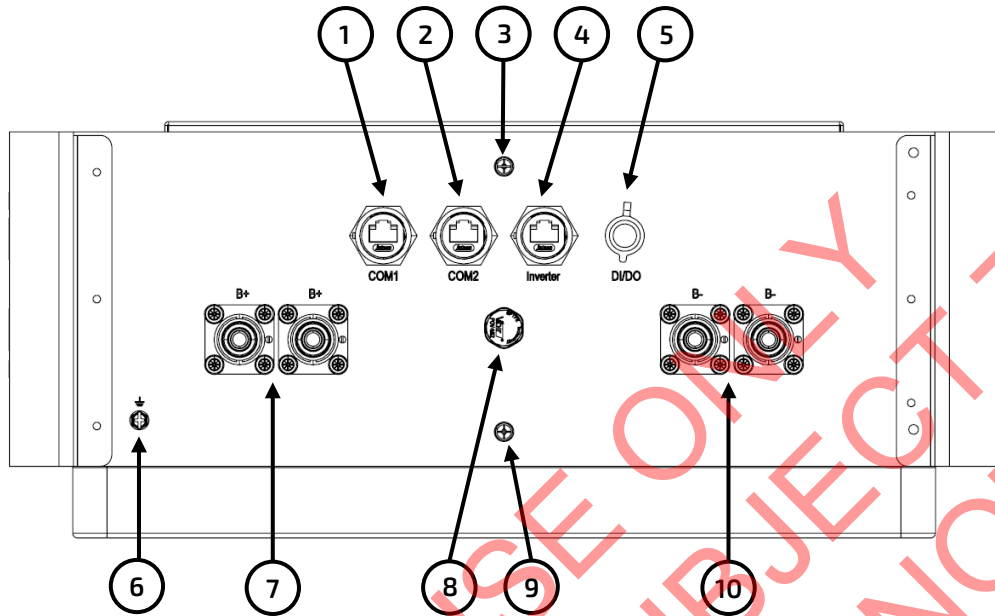

Figure 2: Battery Module Side View

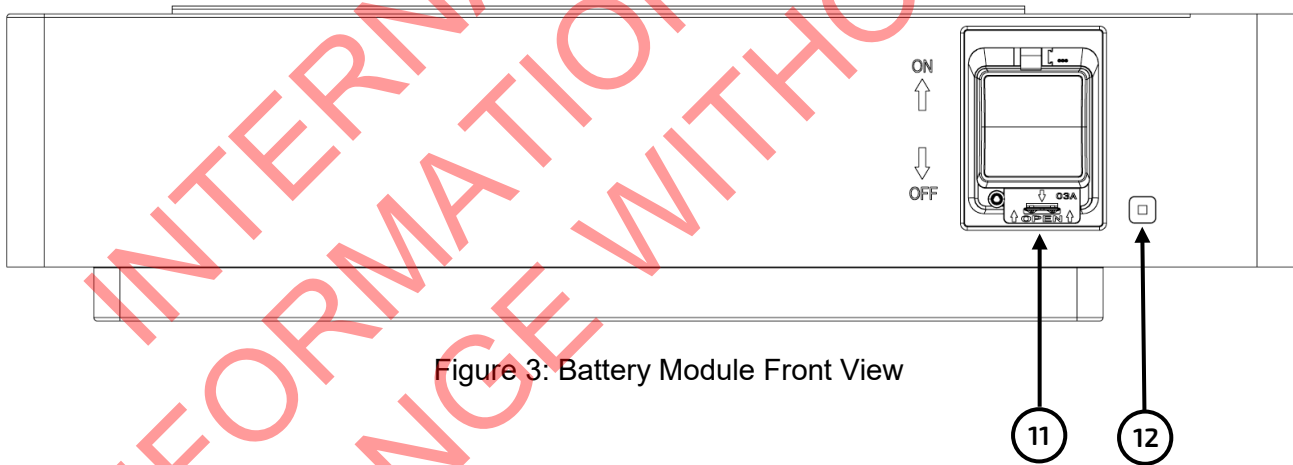

Figure 3: Battery Module Front View

- | | |
|-----------------------------------------------------|-----------------------------------------------------|
| 1. Communication port 1 | 7. Battery positive connections |
| 2. Communication port 2 | 8. Pressure relief valve |
| 3. Upper chassis connector mounting hole with screw | 9. Lower chassis connector mounting hole with screw |
| 4. Inverter communication port | 10. Battery negative connections |
| 5. DI/DO connection | 11. Breaker |
| 6. Ground connection with screw | 12. Battery operation LED indicator |

Control Module Components

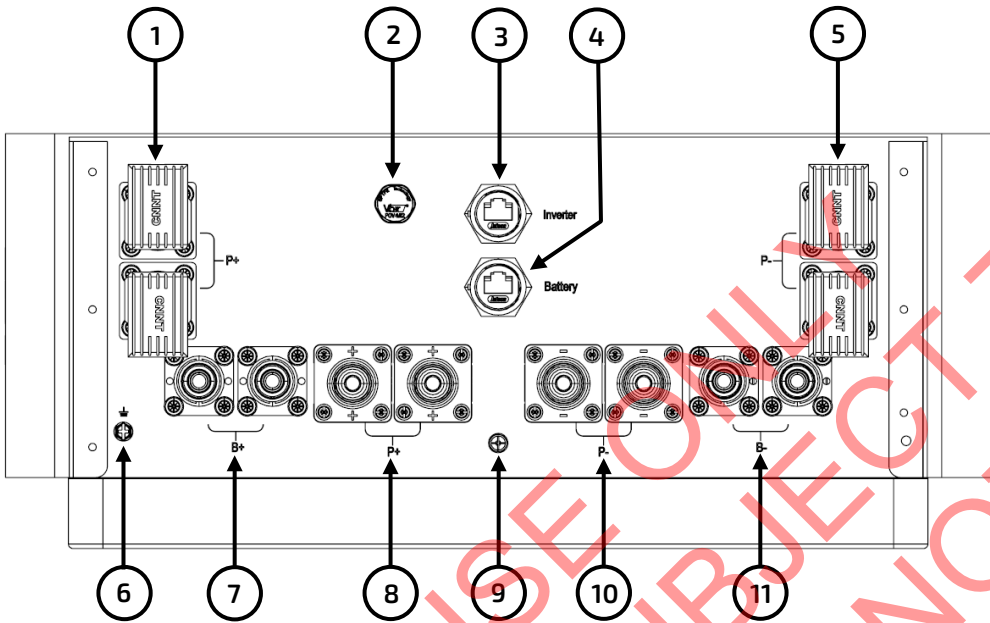

Figure 4: Control Module Side View

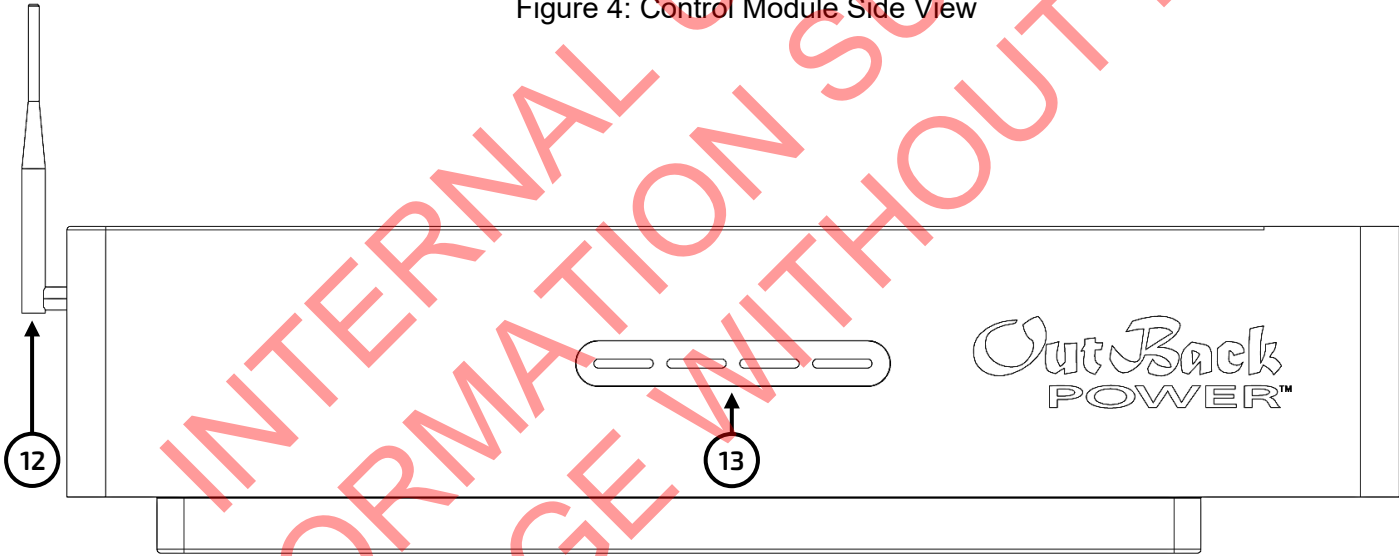

Figure 5: Control Module Front View

- 1. Battery parallel positive connections
- 2. Pressure relief valve
- 3. Control module to inverter communication port
- 4. Control module to battery communication port
- 5. Battery parallel negative connections
- 6. Ground connection with screw
- 7. Control module to battery positive connections
- 8. Control module to inverter positive connections
- 9. Chassis connector mounting hole with screw
- 10. Control module to inverter negative connections
- 11. Control module to battery negative connections
- 12. Wi-Fi antenna
- 13. Battery state of charge indicators

Dimensions

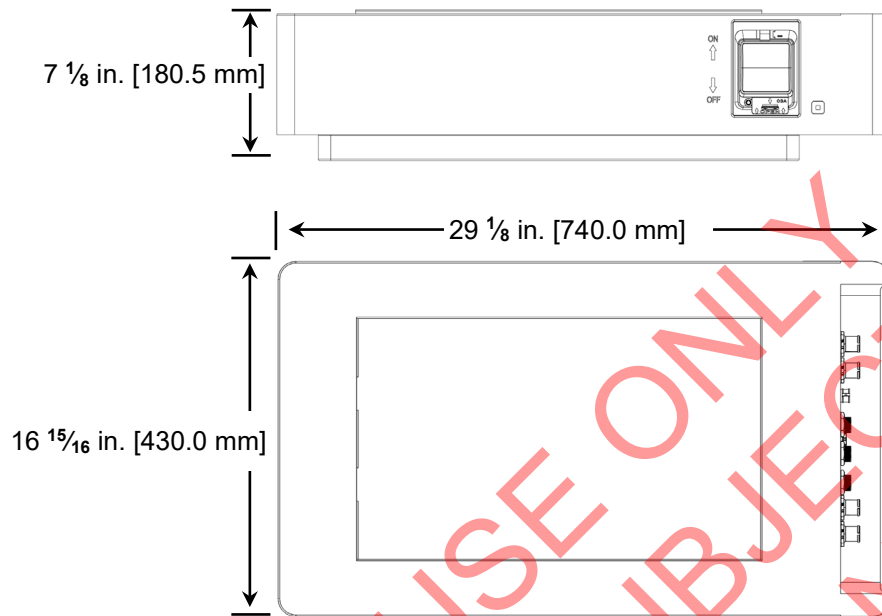

Figure 6: Battery Module Dimensions

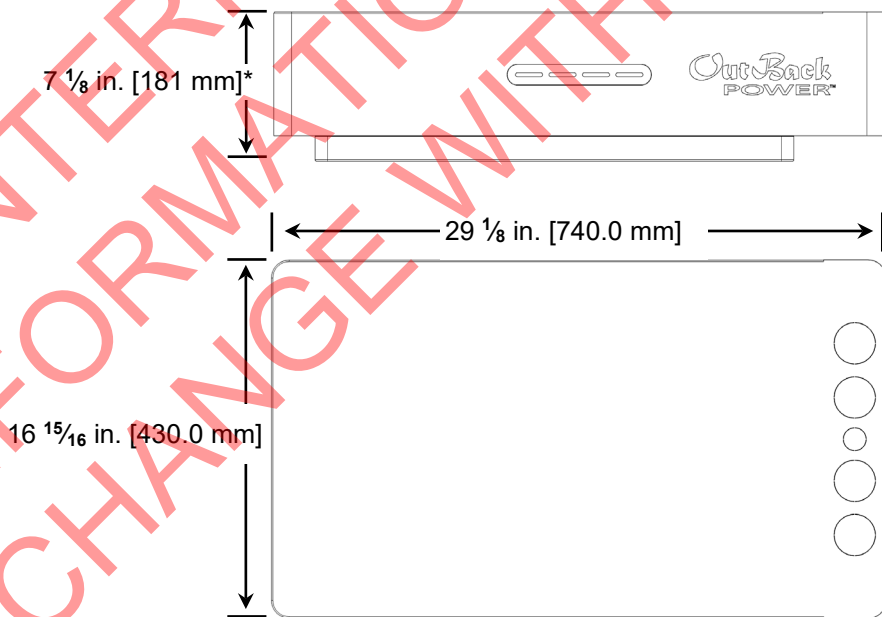

Figure 7: Control Module Dimensions

* Without antenna. Total height with antenna is approximately 12 1/4 in. [312 mm].

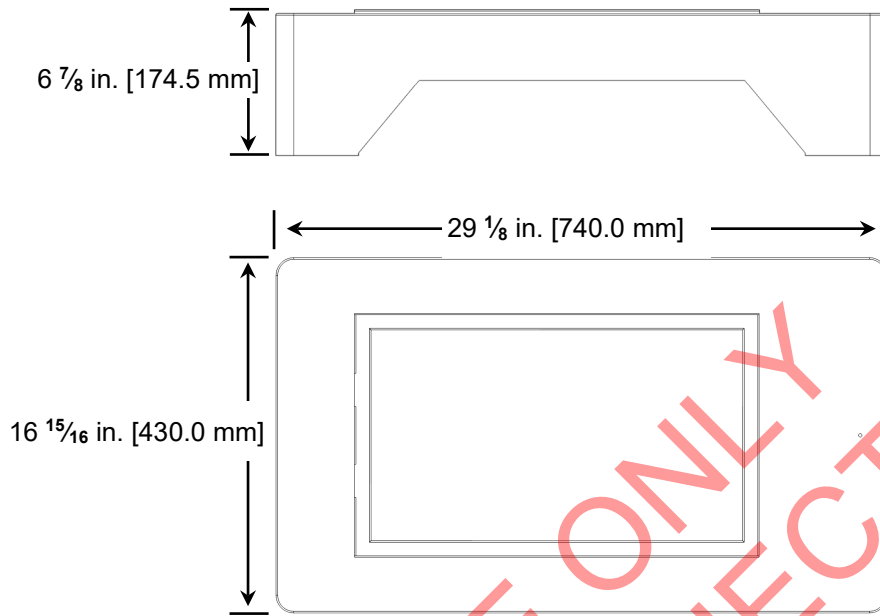
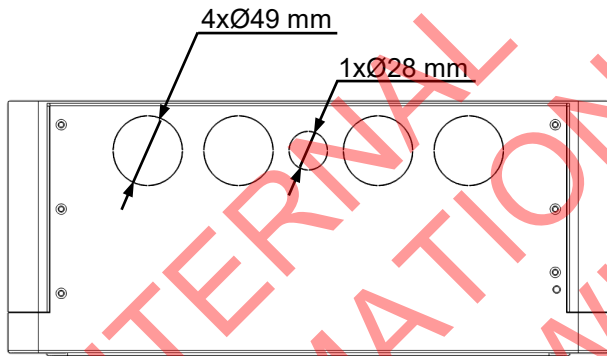

Figure 8: Base Module Dimensions



Actual Knockout Size	US Nominal Trade Size
28 mm	3/4 in.
49 mm	1 1/2 in.



Figure 9: Control Module Knockout Details

Battery Communication

The EnergyCell 5 battery stack can be configured in either an open-loop or closed-loop setup. A closed-loop setup is preferred because it allows for greater data exchange between the inverter and the battery bank. When using an open-loop setup, the inverter only receives limited information from the battery, such as current and voltage.

Closed-Loop

The battery management system (BMS) communicates with supported inverters using a straight-through Cat5/6 Ethernet cable, utilizing either CAN or RS485 protocols. The master battery automatically detects and chooses the inverter type and battery ID as each battery powers on and initializes.



NOTE:

The inverter model and battery ID cannot be manually configured.

Supported Inverter Protocols:

CAN: EG4, Growatt, Solark, Deye, Megarevo, Luxpower, Pylon, Victron, Solis, SMA

RS485: EG4, Growatt, Schneider, Voltronic

Port Interface Pinout:

COM1	
1	485-B1
2	485-A1
3	AD-DO
4	H/S-H1
5	CAN-H1
6	CAN-L1
7	-
8	-

COM2	
1	485-B1
2	485-A1
3	AD-DI
4	H/S-H1
5	CAN-H1
6	CAN-L1
7	-
8	-

Inverter	
1	485-B2
2	485-A2
3	+12v
4	CAN-H2
5	CAN-L2
6	GND
7	485-A3
8	485-B3

Open Loop

This setup does not require a communication cable to the inverter. The battery bank supports inverters that accept 48V Lithium Iron Phosphate batteries. This makes the battery bank compatible with a wider range of manufacturers than inverters that use closed-loop communication. The communication cables between the control module and the master battery, as well as between batteries, are still used to support functions like ESS shutdown and cell balancing.

OutBack Integration

The EnergyCell 5 ESS can be integrated with existing OutBack inverters. For additional information, see the following OutBack Integration Guide by scanning or selecting the QR code to the right.





Installation

Location and Environmental Requirements

Proper battery installation is crucial for safety, longevity, and optimal performance.

- The batteries are intended to be installed indoors or outdoors. However, when choosing an installation location, avoid placing the battery in hot or humid environments.
 - The batteries will operate normally in a range of 4°F – 131°F [-20°C – 55°C], and carry an IP65 ingress protection (IP) rating and a 0 – 95% relative humidity (RH) rating.
- Units intended for indoor residential use should only be installed in attached or detached garages, sheds, enclosed utility closets, basements, storage, or utility spaces within dwelling units. These units are not meant for installation in habitable or living areas within dwellings. The system must be installed in accordance with local, electrical, building, fire, and other relevant codes or utility requirements, as specified by qualified personnel, following the installation instructions and proper practices.
- The typical spacing between battery stacks is 3 feet [914 mm]. AHJs may authorize a reduction to a minimum of 6 inches [152 mm], as supported by the UL 9540A Large Scale Fire Testing Report. The allowance for spacing reduction is subject to jurisdictional approval and is not universally guaranteed.

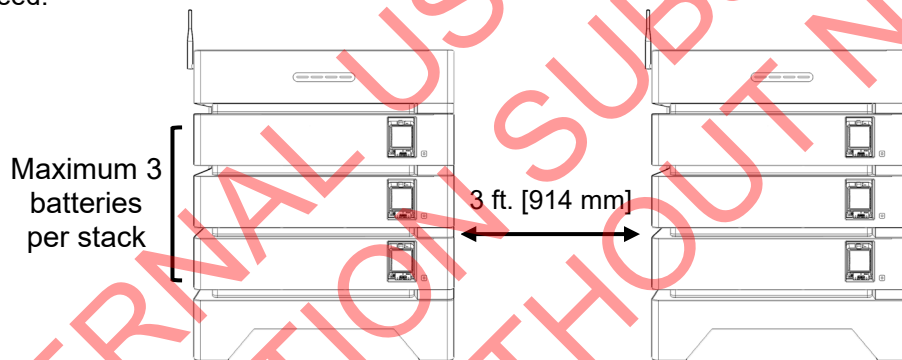

Figure 10: Stack Spacing Requirements



IMPORTANT:

To comply with UL 9540 safety standards, individual battery stacks are generally limited to a maximum capacity of 20kWh or system aggregate limits of 40kWh/80kWh, depending on the installation location. For EnergyCell 5, this would be three batteries per stack. However, some Authorities Having Jurisdiction (AHJs) may allow systems to exceed these limits based on UL 9540A Large Scale Fire Testing data.

Before purchasing or installing an energy storage system, verify that the design complies with all applicable codes and requirements established by your local jurisdiction, fire department, and utility provider.

The manufacturer's installation instructions do not supersede local codes and regulations. Each jurisdiction may interpret codes and safety standards differently. Early engagement with local officials can save time, money, and headaches.

Recommended Tools

The recommended tools may vary depending on the installation location. Typically, the following items are needed to install EnergyCell 5 batteries:



Safety Goggles



Dielectric Shoes



Insulated Gloves

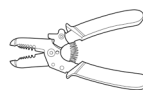

Wire Stripper



Multimeter



Insulated Phillips Screwdriver



Socket Set



Electric Drill and Drill Bits



Insulated Slotted Screwdriver

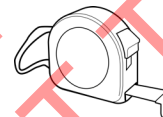

Tape Measure



WARNING:

Do not wear loose clothing, metal jewelry (such as rings, watches, necklaces, bracelets, etc.), or conductive accessories and tools when working with electrical components. Avoid synthetic fabrics that can generate static electricity. Always wear Personal Protective Equipment (PPE) as required.

INTERNAL USE ONLY
ELECTRICAL
INFORMATION SUBJECT TO
CHANGE WITHOUT NOTICE

Single Stack Installation and Cabling



CAUTION: Battery Damage

Improper handling may lead to short circuits or damage to the battery pack, potentially resulting in battery leakage or fire.



NOTE:

The maximum supported number of batteries in a single stack is 8. To comply with UL 9540 safety standards, individual battery stacks are generally limited to a maximum capacity of 20kWh. For EnergyCell 5, this would be three batteries per stack. However, some Authorities Having Jurisdiction (AHJs) may allow systems to exceed these limits based on UL 9540A Large Scale Fire Testing data. Before purchasing or installing an energy storage system, verify that the design complies with all applicable codes and requirements established by your local jurisdiction, fire department, and utility provider.

1. Remove the wiring cover plate screws labeled "A" and the ground screws labeled "B" from each module cover using an insulated Phillips screwdriver. Set the screws and cover plates aside for reassembly later.

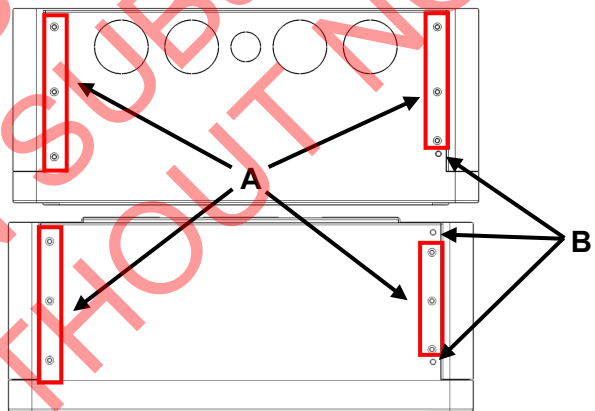

Figure 11: Cover Plate Locations

2. Choose a location to install the EnergyCell 5 battery.
 - Avoid placing the battery in areas with high temperature or humidity.
 - Verify the location is on a clean, flat surface.

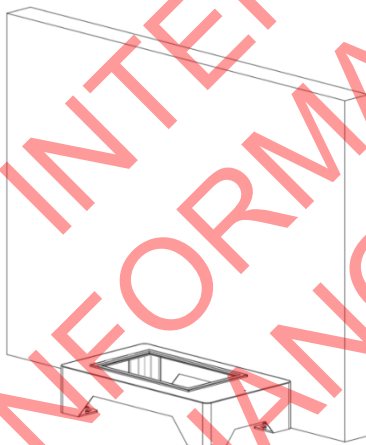

Figure 12: Base Placement

3. Position the base approximately 2 ½ in. [64 mm] from the wall. After the battery base is in a secure position, stack the battery module on top of the battery base. Two or more people may be required to install it due to its weight.

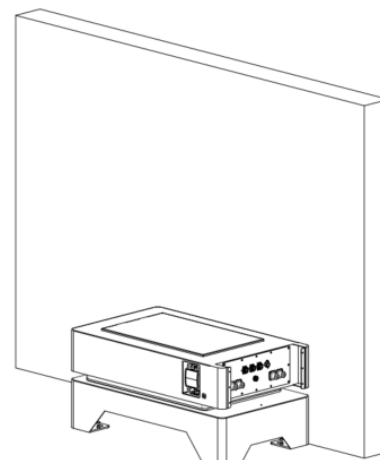

Figure 13: Battery Placement

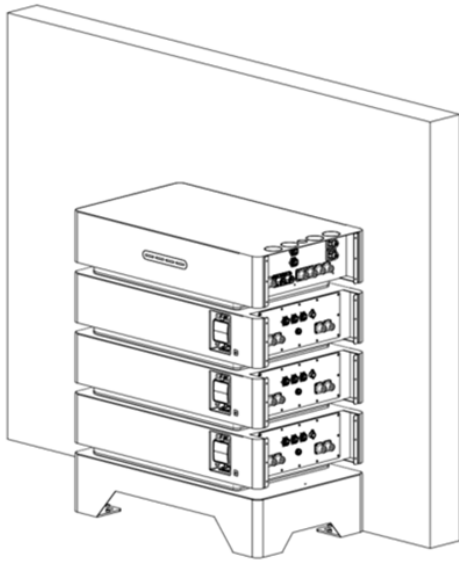

Figure 14: Control Module Placement

4. After stacking the batteries onto the battery base (maximum of 8 per stack), place the control module on top of the top battery.

See the important note under “Location and Environmental Requirements” for additional details on stack sizing limitations and local codes.

5. Install the module connector brackets, provided in each product box, between the base, batteries, and control module.
 - Remove and reuse the screws that are pre-installed in each module.

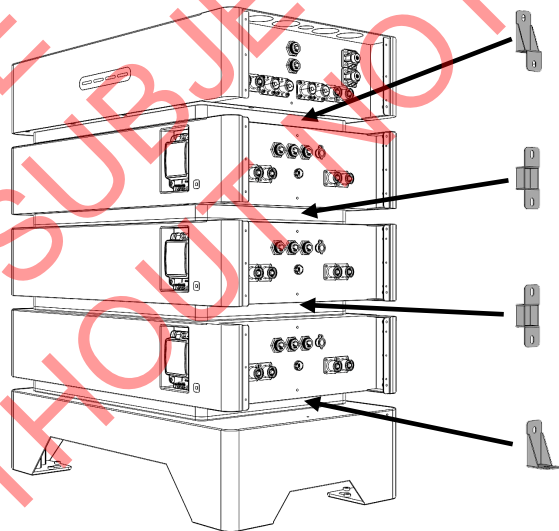

Figure 15: Module Connector Locations

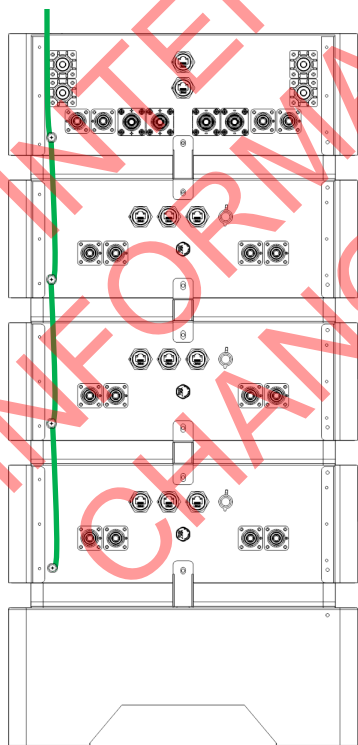

Figure 16: Ground Wire Locations

6. Install a grounding wire to each battery and control module. Ground cables are shown in green.
 - Remove the pre-installed ground screw from the lower left corner of each battery and the control module.
 - Attach the system ground wire to the ground connection point on the control module.
 - Attach a ground wire from the ground screw on the control module to the top battery grounding connection point and tighten the screws. Then continue down the stack to the last battery.



WARNING:

Make sure all battery breakers are in the open (OFF) position before installing or working on each battery. Verify there is no voltage using a multimeter to prevent electric shock.

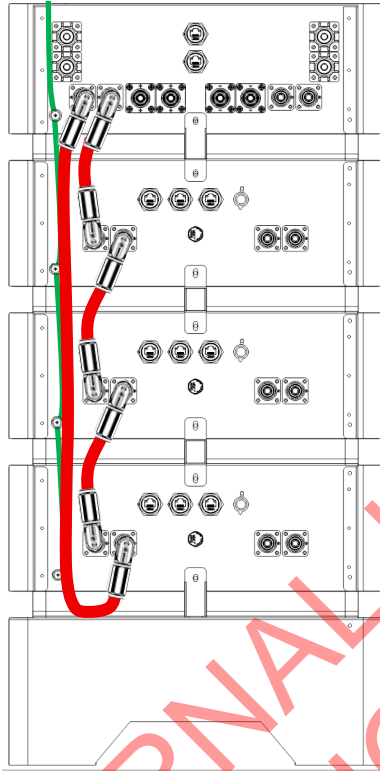

Figure 17: Positive Power Cables

7. Before connecting battery power cables, verify the battery breakers are in the open (Off) position.

Connect the red positive power cables, as shown in the image. Be sure to line up the Degson connector with the keyway on the module connector for proper connection.

- Connect a positive cable from the “B+” port of the control module to the “B+” port on the top battery. This cable is included with the battery.
- Connect a positive power cable to the “B+” battery ports between each battery, working down the stack. This cable is included with the battery.
- Connect the “B+” port of the control module to the “B+” port on the bottom battery in the stack using the return power cable. This cable is included with the control module.



CAUTION: RETURN POWER CABLES

Using a positive and a negative return power cable is required to handle the amperage load when stacking two or more batteries. Failing to connect the return power cable can lead to overheating, which may damage equipment and cause a fire.

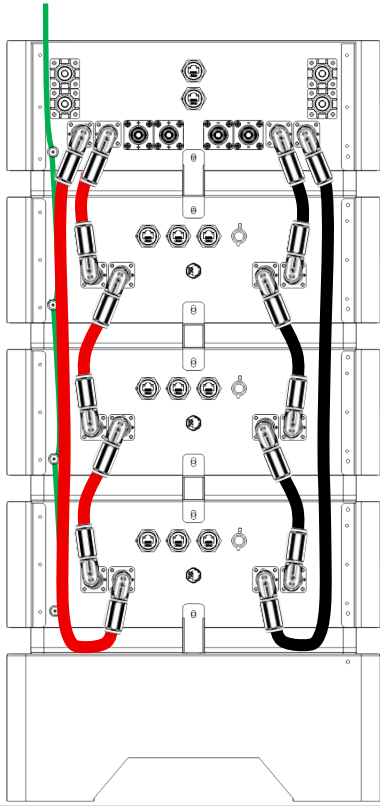

Figure 18: Negative Power Cables

8. Connect the black negative power cables, as shown in the image. Be sure to line up the Degson connector with the keyway on the module connector for proper connection.

- Connect a negative cable from the “B-” port of the control module to the “B-” port on the top battery. This cable is included with the battery.
- Connect a negative power cable to the “B-” battery ports between each battery, working down the stack. This cable is included with the battery.
- Connect the “B-” port of the control module to the “B-” port on the bottom battery in the stack using a return power cable. This cable is included with the control module.

9. When using closed-loop communication, install communication cables between each device as shown by the blue cables in the image. Communication cable all-weather connector covers are included with each battery and the control module. Use standard ethernet cables with RJ45 connectors when making the communication cables. Be sure to slide the all-weather connector cover onto the ethernet cable before crimping the end on the cable.

- Connect a communication cable from the “Battery” port on the control module to the “Inverter” port on the top battery in the stack. The top battery will become the master battery for a stack of two or more batteries.
- Connect a communication cable from the “COM2” port of the master battery to “COM1” of the battery below. Then, continue connecting a communication cable from “COM2” to “COM1” for each additional battery added to the stack, as shown in the image on the left.

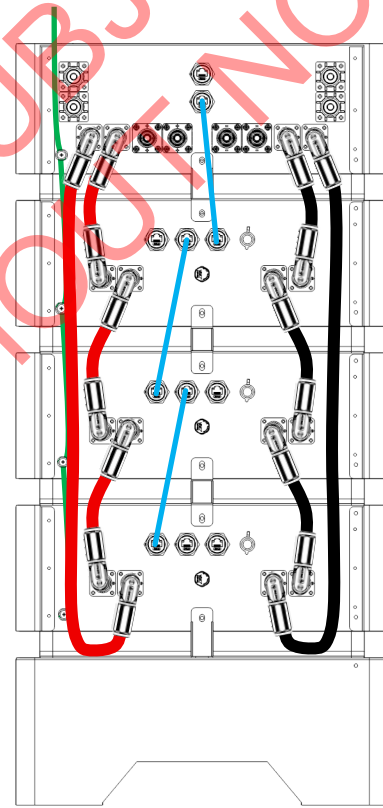

Figure 19: Communication Cable Locations



CAUTION: Battery Damage

Connecting “COM1” or “COM2” from one battery to the “Inverter” port of another battery can damage the batteries. The master battery “Inverter” port should only be connected to the control module “Battery” port.

Installation

10. When using closed-loop communication, connect the 120 Ω RJ45 terminating resistor to the open “COM1” port on the master battery when using a single stack of 2 to 8 EnergyCell 5 batteries. When using multiple stacks, refer to the section on “Multiple Stacks in Parallel” for proper placement.

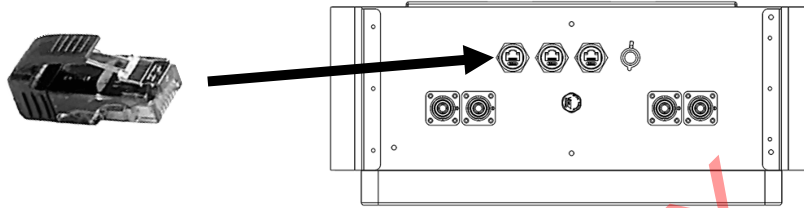

Figure 20: RJ45 Terminator Location



CAUTION: Battery Damage

Connecting “COM1” or “COM2” from one battery to the “Inverter” port of another battery can damage the batteries. The master battery “Inverter” port should only be connected to the control module “Battery” port.

11. Ensure all batteries and inverter(s) are powered off before making any connections to the control module or the inverter.

- Connect a power cable from the control module “P+” port to the inverter positive battery port, as shown by the red cables in the image. A red Degson connector is included with the control module that can be used on the control module end of the cable.
- Connect a power cable from the control module “P-” port to the inverter negative battery port, as shown by the black cables in the image. A black Degson connector is included with the control module that can be used on the control module end of the cable.
- Connect an RJ45 CAT5/6 communication cable from the control module “Inverter” port to the inverter battery communication port. Communication cables are shown as the blue cable in the image. To maintain the waterproof rating with each connection, use the included RJ45 connection covers.

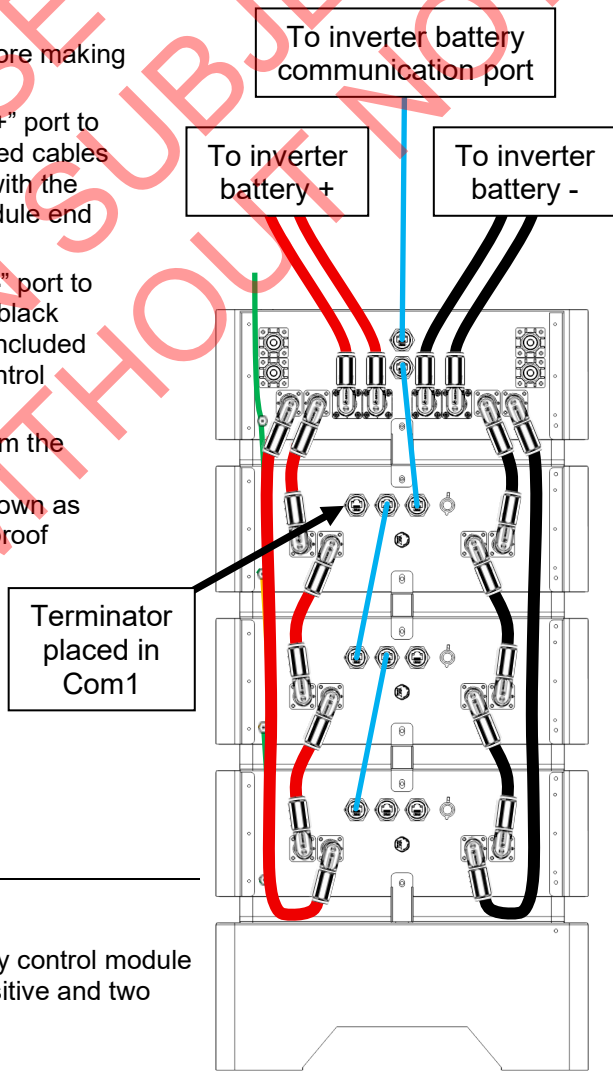

Figure 21: Inverter Power Cables



CAUTION: Equipment Damage

When the inverter is connected to the battery control module can draw over 200 amps, it requires two positive and two negative power cables.

When three or more batteries are installed in a stack, an Overcurrent Protection Device (OCPD) with the proper rating must be installed. See “Design Guidelines” on page 24 for sizing guidelines.

12. If installing ESS Emergency Disconnect, connect the included DO/DI emergency disconnect cable.

- The DI cable connected to a normally closed stop switch (not included) serves as an Energy Storage System (ESS) disconnect, which can be used to shut down the entire stack of connected EnergyCell 5 batteries. When paralleling multiple batteries, the ESS disconnect only needs to be connected to the master battery. This safety feature is part of the battery communication system and is shared with all connected batteries through the included CAT5 Ethernet cables.
- Attach the DO/DI connector to two black wires labeled “DI” to a normally closed stop switch (not included) as shown below. Then, plug the DO/DI cable into the master battery “DI/DO” port.

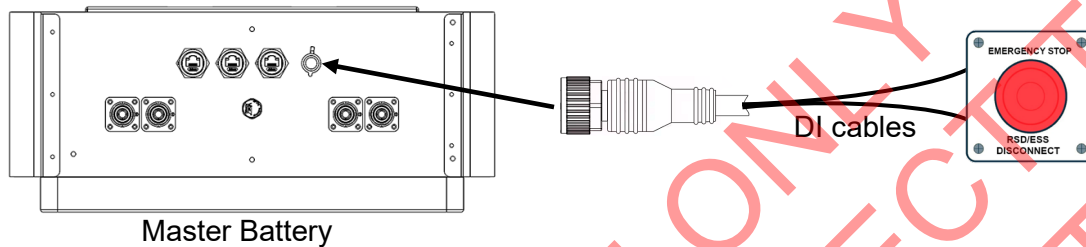

Figure 22: DI/DO Cable Connections



NOTE:

When using closed-loop communication between the inverter and EnergyCell 5 control module, certain inverter models can trigger a complete system shutdown, including the batteries, by activating the inverter's rapid shutdown (RSD) feature. In this scenario, the DI cable will not be used to activate the ESS shutdown of the batteries, as this will be controlled by the inverter, if supported. Refer to the inverter's user manual for more details.

It is recommended to ensure the installation complies with all relevant RSD/ESS standards and requirements, as established by the National Electrical Code, local jurisdiction, fire department, and utility provider.

13. Install the cable cover plates.

- Check that all wiring connections are secure and within the cable box area. Align the cable cover plates with the control module and battery modules, then attach the cover plates using the screws removed in step 1.

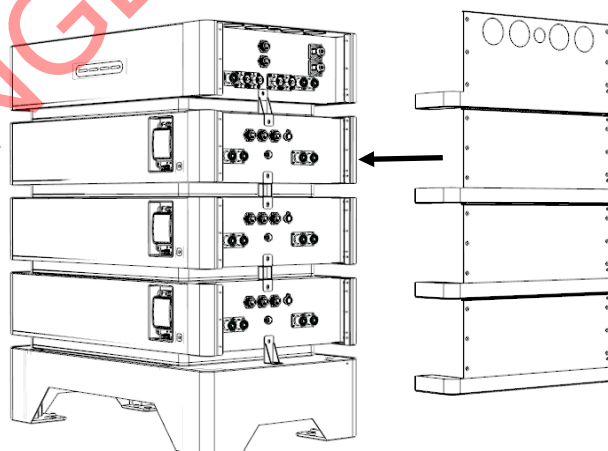

Figure 23: Module Cover Plates

Installation

14. Lastly, secure the modules to the wall:

- Remove the pre-installed screws from the module where the L-bracket will be installed.
- Temporarily mount the provided L-bracket to the side of the module using the screws that were just removed.
- Mark the hole placement on the wall using the bracket as a template.
- Remove the bracket and drill an appropriate pilot hole in the wall for the type of fastener to be used.
- Attach the bracket to the module and the wall.

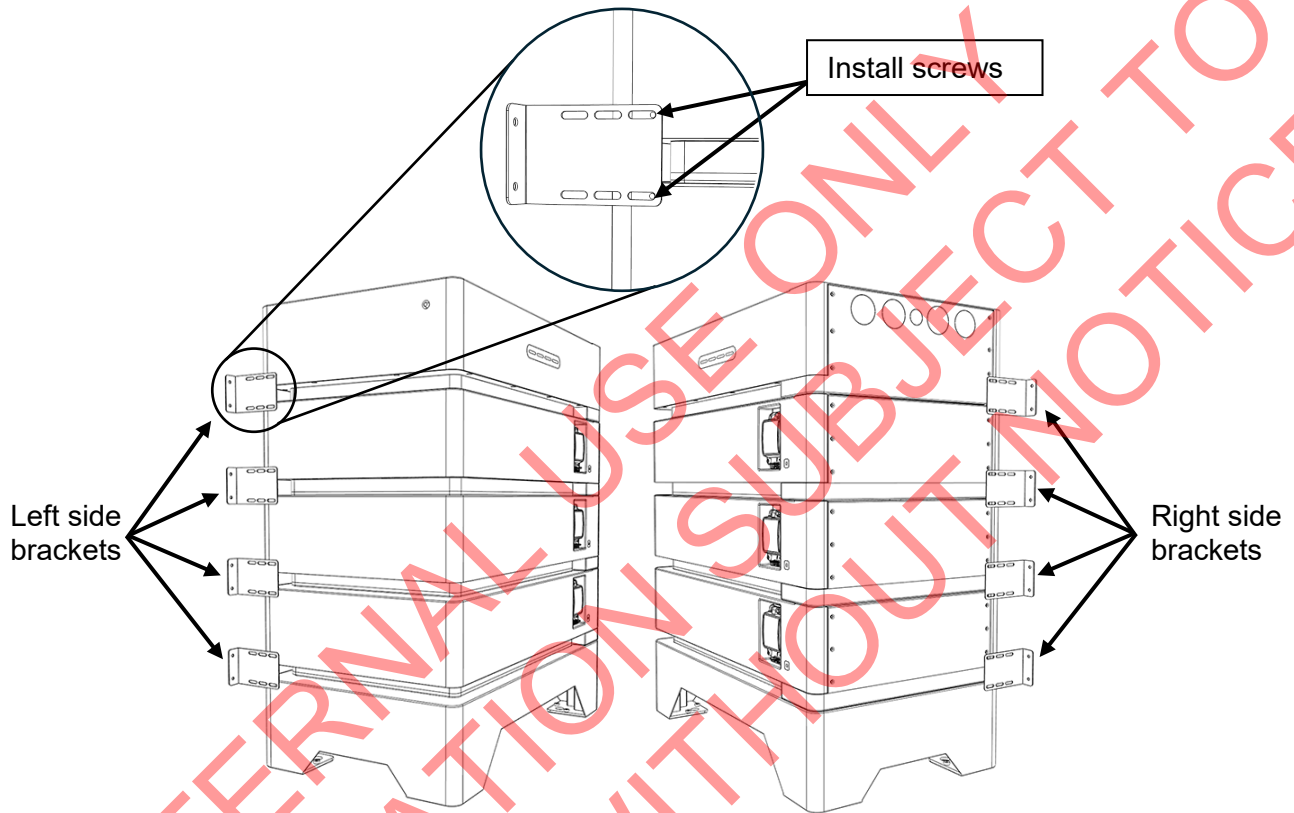

Figure 24: Module Bracket Locations



WARNING:

Stacked battery modules are heavy and can become unstable if not properly secured to the wall. An unsecured stack may tip over, resulting in:

- Severe injury or death from crushing or impact.
- Damage to battery modules, which could lead to electrical hazards, short circuits, or fire.

To prevent tipping:

- Install the supplied wall brackets or approved anchoring hardware.
- Use the correct wall anchors designed for the wall material where the brackets are installed.
- Ensure the floor and wall surfaces are level, stable, and capable of supporting the full system weight.

Failing to secure the battery stack to the wall using the included brackets can lead to serious injury, equipment damage, or fire.

Design Guidelines

This section details supported configurations for using one or more inverters with one or more battery stacks. Read this section carefully to ensure proper planning before installing equipment.

All Stacks

When planning and designing an energy storage system with EnergyCell 5, the following items should be considered:

- The maximum supported load is 300 amps for the entire system, whether it's a single stack or two to three stacks in parallel.
- A single inverter can be connected to a single stack, or two or three parallel battery stacks.
- If two or more inverters are connected in parallel, each inverter must be connected to a dedicated battery stack split banks.
- Ensure the required overcurrent protection device (OCPD) is installed between the inverter and control module to safeguard the power cables and battery stack from potential damage. The OCPD that is integrated into the inverter must meet the specifications listed below. If not, a separate, properly rated OCPD must be installed between the inverter and battery control module.
 - If the maximum load can be set at or below 200A, an OCPD rated for at least 60VDC at a maximum of 200A is required.
 - If the maximum load can be set at or below 300A, an OCPD rated for at least 60VDC at 300A is necessary.
- A single set or double set of power cables may be required when connecting the inverter.
 - A single set of 2/0 cables must be used to support a 200A load. A set of cables are included with the control module.
 - A double set of 2/0 cables must be used to support a 300A load. Only one set of cables is included. If a second set is needed, Degson connectors can be purchased for creating custom cables.

Parallel Battery Stacks

When connecting two or three battery stacks to a single inverter, the following requirements must be met:

- Battery stacks must be connected in parallel so the load can be evenly distributed between stacks.
- Two positive and two negative 2/0 AWG power cables must be used between each stack.
- Use the appropriately sized power cable(s) between the inverter and battery control module according to the maximum load.
- Use the included RJ45 waterproof connector covers when creating and installing the RJ45 parallel communication cable between stacks. This cable is not included, but any shielded CAT5/6 cable can be used.
- See Figures 25 and 26

**NOTE:**

Connecting battery stacks in parallel requires additional power and communication cables that are not included with the system.

For each additional battery stack the following cables are required:

- Shielded CAT5/6 Communication cable with RJ45 connectors
- 2/0 AWG positive power cable w/compression ring terminal (x2)
- 2/0 AWG negative power cable w/compression ring terminal (x2)

Dedicated Battery Stacks

When setting up two or more inverters in parallel, each inverter must be connected to its own dedicated battery stack. Ensure that the following requirements are met:

- A battery stack must be connected to each inverter so the current can be dedicated to each inverter.
- Use the appropriately sized power cable(s) between the inverter and battery control module according to the maximum load.
- Do not connect the battery stacks together with power cables or a communication cable.
- See Figure 27

INTERNAL USE ONLY
INFORMATION SUBJECT TO
CHANGE WITHOUT NOTICE

One Inverter with 2 Parallel Stacks Diagram

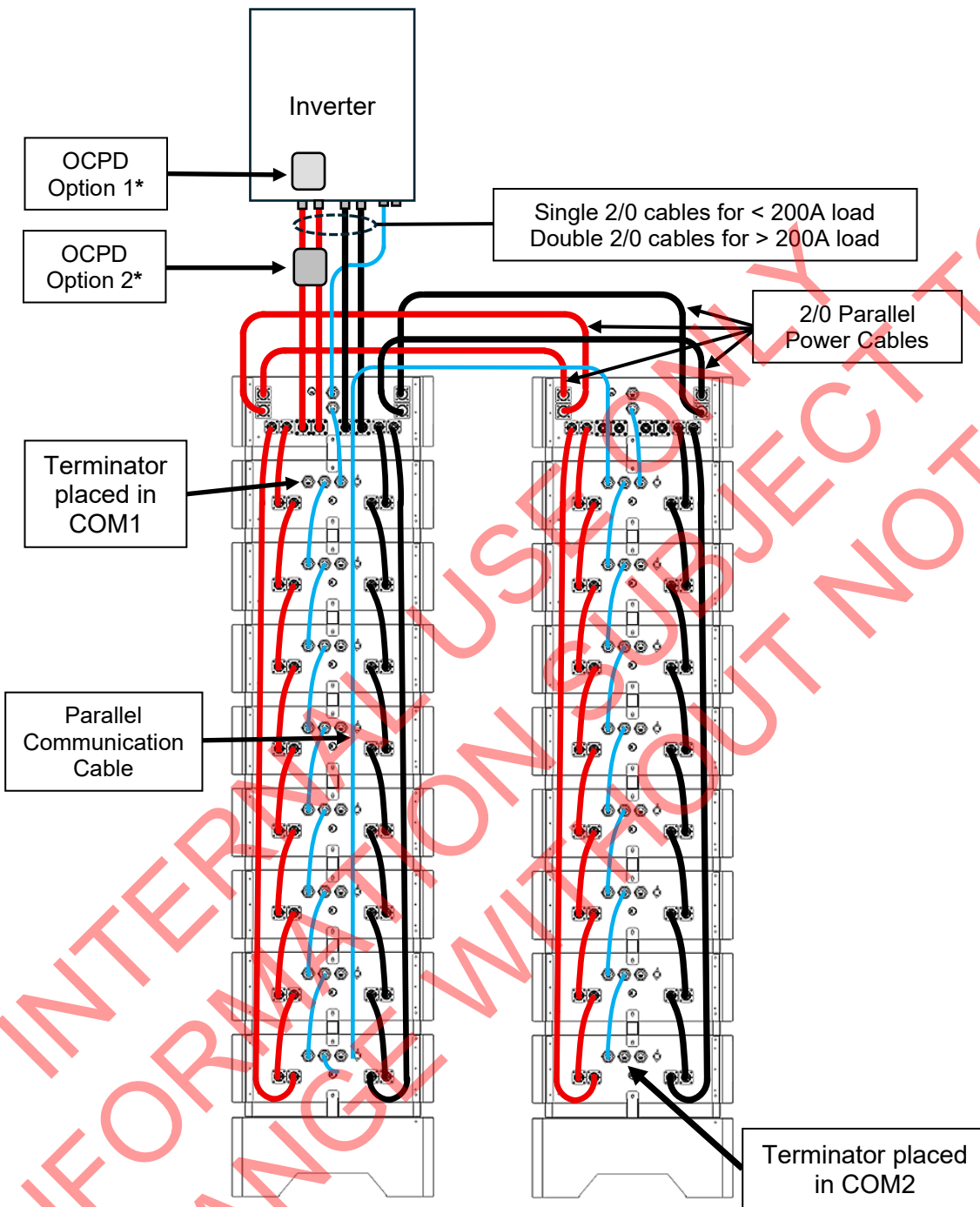

Figure 25: Two Parallel Battery Stacks

*See page 24 for specifications



NOTE:

The battery layout shown is a side view, provided for wiring illustration purposes only. Proper system installation requires the battery stack to be front-facing and securely mounted to the wall using wall brackets. For correct placement and installation, refer to “Single Stack Installation and Cabling” for more information.

One Inverter with 3 Parallel Stacks Diagram

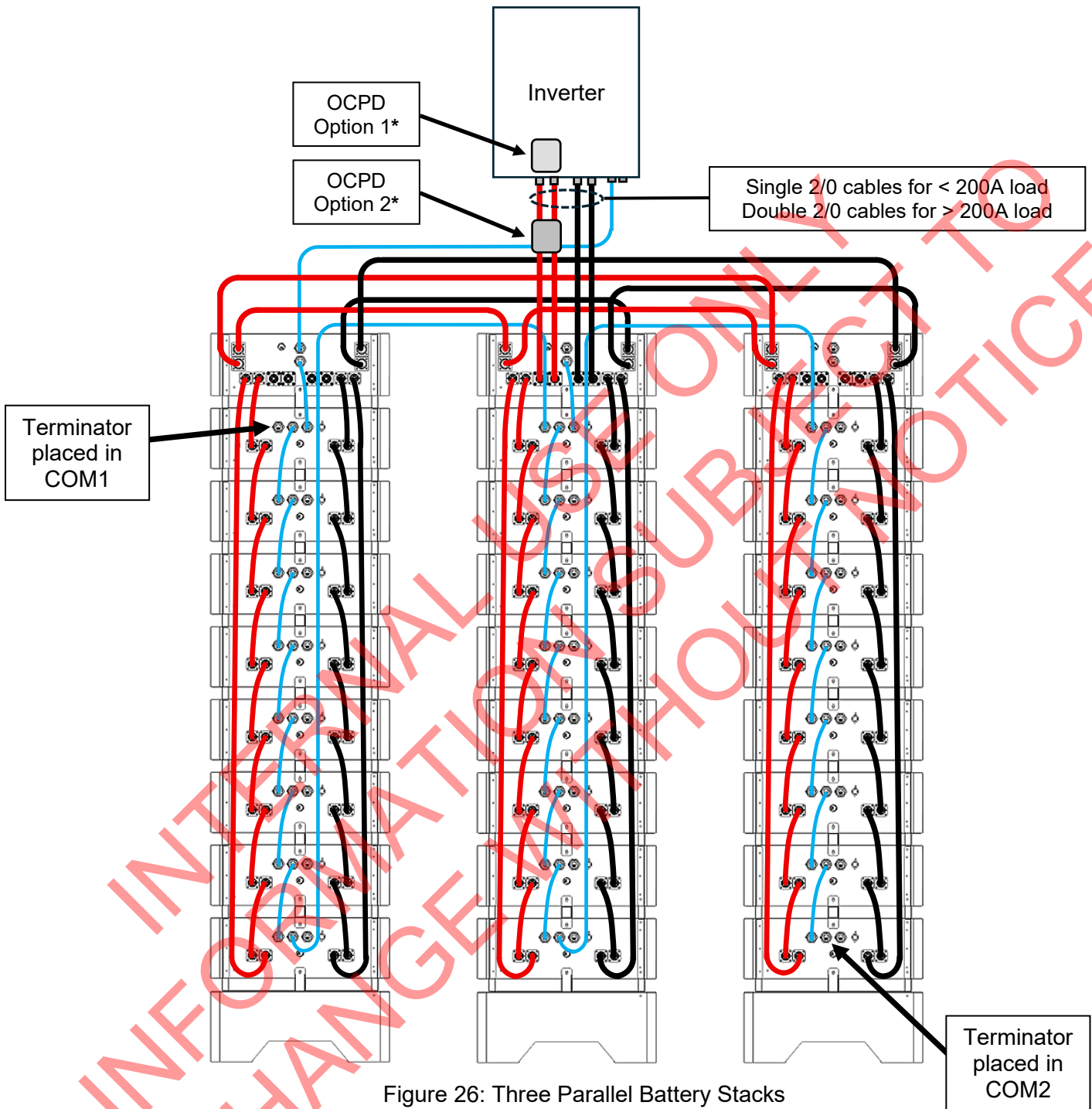

*See page 24 for specifications



NOTE:

The battery layout shown is a side view, provided for wiring illustration purposes only. Proper system installation requires the battery stack to be front-facing and securely mounted to the wall using wall brackets. For correct placement and installation, refer to "Single Stack Installation and Cabling" for more information.

Parallel Inverters with Dedicated Stacks Diagram

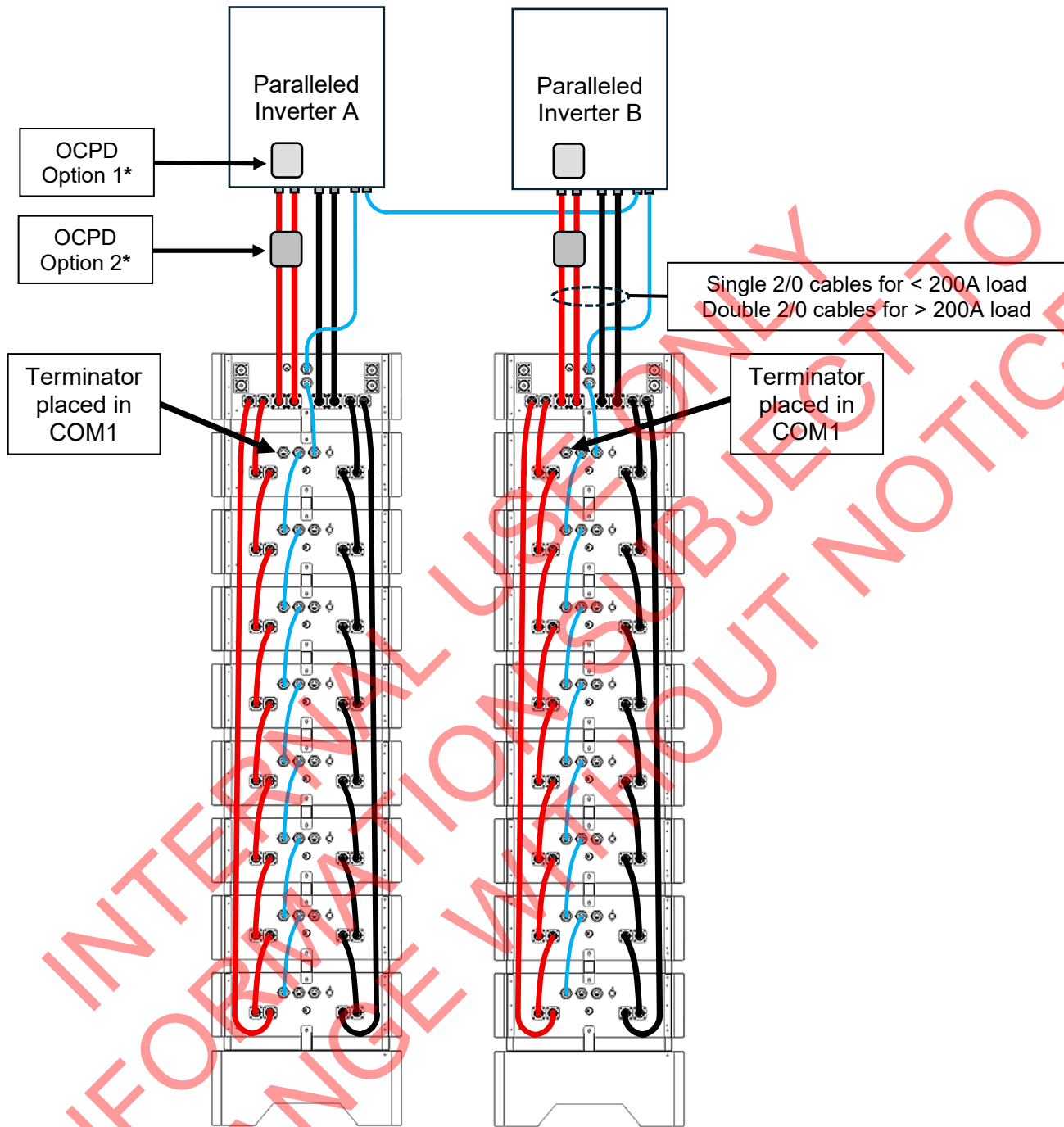

Figure 27: Dedicated Battery Stacks

*See page 24 for specifications



NOTE:

The battery layout shown is a side view, provided for wiring illustration purposes only. Proper system installation requires the battery stack to be front-facing and securely mounted to the wall using wall brackets. For correct placement and installation, refer to “Single Stack Installation and Cabling” for more information.



Commissioning

Functional Test

It is highly recommended that all applicable steps be taken in the following order. However, if steps are inapplicable, they can be omitted.

Pre-Power Up Procedures

After installation, the EnergyCell 5 lithium battery needs to be started up. Before starting up, ensure the following precautions are taken.

1. All electrical connections must be made in accordance with the installation steps and electrical diagrams in the manual.
2. Double-check that all cables are connected correctly and verify the grounding cable connection.
3. Ensure all DC overcurrent devices are OFF.



CAUTION: Equipment Damage

Incorrect battery polarity will damage the battery. This damage is not covered by the warranty.

Power Up

To power up the battery:

1. Double-check that all cables are connected correctly.
2. Ensure the grounding and RSD wiring are properly connected.
3. Turn on the switch located on the battery side of the inverter or between the inverter and the battery.
4. Turn on the master battery breaker, then proceed down the stack. As the batteries power on, the green LED will flash amber while the master battery sets the addresses of the other batteries.
5. After all the battery LEDs are solid green, turn on the inverter.

INFORMATIONAL USE ONLY
SUBJECT TO
CHANGE WITHOUT NOTICE

Powering Down

If the battery system must be turned off, follow the steps below in the following order:

1. Turn off the inverter.
2. Switch off the breaker between the battery and the inverter.
3. Switch off each battery breaker to turn off the battery system.

System Charge

When the battery system is transported or stored for an extended period, the battery's State of Charge (SOC) may decrease due to self-discharge of the cells. It is recommended that each battery be at least 20% State of Charge (SOC) before applying loads. If the battery stack is below 20% SOC, charging can be performed using the inverter connected to the battery stack.

It is also recommended not to discharge the battery below 20% SOC. While LiFe PO batteries can technically handle full discharges, consistently draining them to 0% SOC can greatly reduce their lifespan, accelerate capacity loss, and increase the likelihood of BMS protection events. OutBack Power strongly advises maintaining a 20% SOC to 80% Depth of Discharge (DoD) for optimal battery life, efficiency, and reliability.

Phone App

A phone app can be downloaded and installed on both Apple and Android devices from their online app stores. Once installed, the app allows users to view information about each battery and the entire stack. After installing the app, follow the instructions below to finish setting up and connecting to the battery stack.

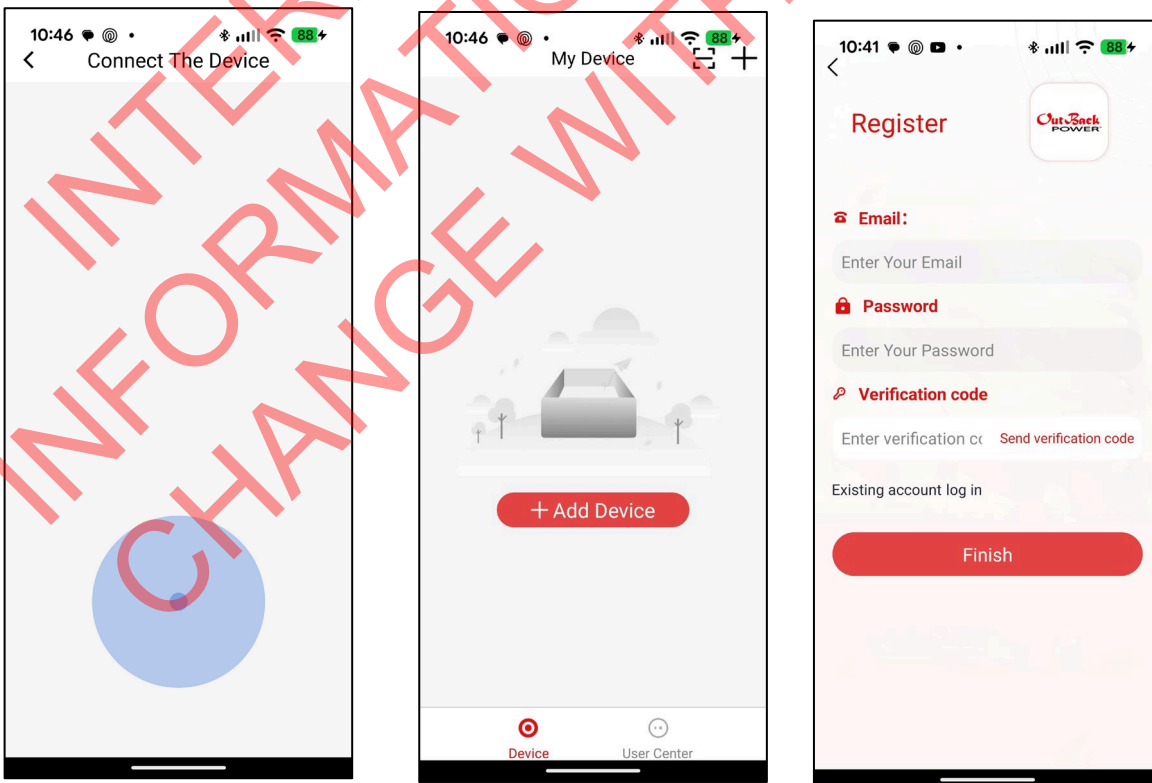



Troubleshooting

Common Issues and Solutions

Issue	Analysis	Solution
Communication failure with the inverter.	Communication port connection error or an unsupported inverter.	Check communication cable connections.
No DC output.	The breaker is either open, or the battery has low voltage.	Close the breaker or charge the battery.
The battery life is too short.	Insufficient battery capacity or not fully charged.	Maintenance or replacement
The battery can't be fully charged.	The DC output voltage drops below the minimum charging voltage.	Regulating the DC output voltage of the power supply to an appropriate charging voltage.
The battery's output voltage is unstable	BMS is not functioning properly.	Reset and reboot the system.
Different SOC levels in batteries connected in parallel.	Normal fault	No operation

LEDs

Use the chart below to determine battery LED information:

LED COLOR	LED STATE	MEANING
Green	Solid	Powered on and idle
Green	Blinking	Charging or discharging
Red	Solid	Protection
Red	Blinking	Auto-addressing or miscommunication

System Maintenance

Routine maintenance information is shown in the table below.

Item	Maintenance	Time Between
Power Cables	<ul style="list-style-type: none"> Inspect the power cable for any signs of mechanical damage and make sure that the terminal insulation sleeves are intact and not falling off. If any damage is found, turn off the system and perform maintenance or replace the cable. Ensure the power cable is secure and not loose. If it is loose, use a standard torque wrench to tighten it. Check the system for loose screws or discoloration of the copper busbar. If the screws are loose, tighten them with a torque wrench. If the copper busbar is discolored, contact the distributor for after-sales replacement. 	Once every 6 months
Communication Cables	<ul style="list-style-type: none"> Verify that the terminals of the parallel communication cable are securely fastened. 	Once every 12 months
System Running Status	<ul style="list-style-type: none"> Check if all parameters (system voltage, current, temperature, etc.) are normal when the system is running. Verify that the main core components of the system, including switches and connectors, are working properly. 	Once every 6 months
Charge and discharge	<ul style="list-style-type: none"> Perform a light load and shallow charge/discharge test to evaluate the normality of the SOC and SOH of the battery. It is recommended that the DOD and charge/discharge power do not exceed 20% of the rated value. 	Once every 6 months

Battery Storage

Store the batteries in a dry, non-flammable location away from strong electromagnetic fields and direct sunlight.

- If the battery is stored for less than three months, it can be fully charged. The temperature storage range is 32°F – 113°F [0°C – 45°C] with a relative humidity of 60±30%.
- If storing the battery for longer than three months, maintain the battery's State of Charge (SOC) at 50% – 70%. Temperature storage range is 68°F – 95°F [20°C – 35°C] with a relative humidity of 50±15%.

Battery Disposal

The EnergyCell 5 battery is designed to last over 10 years with proper use, assuming no more than one charge and discharge cycle daily. When it's time to retire the battery, consider a few important factors. Lithium iron phosphate (LFP) batteries are classified as hazardous materials and should not be discarded with regular trash. Many websites and organizations accept LFP batteries for recycling at little or no cost. We recommend searching online with the phrase "Lithium Battery Disposal Near Me," which should provide a list of organizations that can safely dispose of LFP batteries. Always verify ahead of time whether the location is open and accepting batteries. Before discarding or improperly disposing of the battery, contact OutBack Power customer service for assistance.



Specifications

Battery Module

General Characteristics	
Specification	Value
Model Name	EC-FE5148
Product Type	Low voltage LFP battery pack
Battery Type	Lithium Iron Phosphate (LFP)
Nominal Energy Capacity	100Ah
Nominal Voltage	51.2Vdc
Voltage Range	44.8~57Vdc
Usable Energy (DoD %)	100% (80% recommended)
Continuous Charge/Discharge Power	5kW (2.5kW recommended)
Peak Power (Duration)	7.68kW (2 seconds)
Communication Protocols	RS485, CAN
Electrical Characteristics	
Specification	Value
Charge Voltage Range	56.0+/-0.8Vdc
Discharge Cut-off Voltage	44.8Vdc
Max Continuous Charge Current	100Adc (50Adc recommended)
Max Continuous Discharge Current	100Adc (50Adc recommended)
Max Parallel Units	16 EnergyCell 5 battery modules, 2 EnergyCell 5 control modules
Protection Features	
Specification	Value
Recommended Charging/discharging rate	0.5C
Short circuit protection	>250Adc for 0.1ms
Battery Breaker	125Adc
Interrupt current rating	10kA
Environmental Characteristics	
Specification	Value
Storage Temperature Range	32°F~113°F [0°C~45°C]
Operating Temperature Range	-4°F ~131°F [-20°C~55°C]
Outdoor Rated	IP65
Humidity Range	0 – 95%
Altitude	2000M
Cooling Method	Natural convection

Specifications

Mechanical Specifications	
Specification	Value
Installation Configuration	Ground/Floor Mounted
Battery Stack Limits	3 – 8 modules per stack, 3 stacks max
Dimensions (H × W × D)	7.1" × 16.9" × 29.1" [180 mm × 430 mm × 740 mm]
Weight per Module	132 lbs. [60 kg]
Display Indicators	LEDs
Connector Types	Quick Connects, RJ45, DI-DO
Other Specifications	
Certifications and compliance	UL 1973, UL 9540 DC ESS, UL9540A, UN 38.3
Warranty and lifecycle	≥8000 (0.5C@25°C, 80%DOD) 10 years
Cycle Life (80% capacity)	8000
Design Life	>10 years

Control Module

General Characteristics	
Specification	Value
Model Name	EC-FE5148-CM
Product Type	LV Stackable Control Module
Voltage Range	44.8~57Vdc
Max Continuous Current	300Adc
Operating voltage	56Vdc
Environmental Characteristics	
Specification	Value
Storage Temperature Range	32°F~113°F [0°C~45°C]
Operating Temperature Range	-4°F ~131°F [-20°C~55°C]
Outdoor Rated	IP65
Humidity Range	0 – 95%
Altitude	2000M
Cooling Method	Natural convection
Mechanical Specifications	
Specification	Value
Installation Configuration	Ground/Floor Mounted
Dimensions (H × W × D)	7.1" × 16.9" × 29.1" [180 mm × 430 mm × 740 mm]
Weight	39.7 lbs. [18 kg]
Display Indicators	LEDs
Connector Types	Quick Connects, Screw Terminals, RJ45

Base Module

General Characteristics	
Specification	Value
Model Name	EC-FE5148-B
Product Type	LV Stackable Base Module

Weight	24.25 lbs. [11 kg]
Dimensions (H × W × D)	7.1" × 16.9" × 29.1" [180 mm × 430 mm × 740 mm]

Regulatory Specifications

- UL9540A: Test Method for Evaluating Thermal Runaway Fire Propagation in Battery Energy Storage Systems — Issue: ANSI/CAN/UL 9540A:2019 (Fourth Edition) + UL CRD's
- UL1973: ANSI/CAN/UL Batteries for use in Stationary and Motive Auxiliary Power Applications / Batteries — Issue: 2022/02/25 Ed: 3

INTERNAL USE ONLY
INFORMATION SUBJECT TO
CHANGE WITHOUT NOTICE

Abbreviations



- AWG – American Wire Gauge
- A – Amps
- Ah – Amp hour(s)
- AC – Alternating Current
- AFCI – Arc-Fault Circuit Interrupter
- AHJ – Authority Having Jurisdiction
- kAIC – kilo-Amp Interrupting Capability
- ANSI – American National Standards Institute
- BAT – Battery
- BMS – Battery Management System
- COM – Communication
- CT – Current Transformer
- DC – Direct Current
- DIP – Dual In-line Package
- DOD – Depth of Discharge
- EG – Equipment Ground
- EGS – Equipment Grounding System
- EMC – Electromagnetic Compatibility
- EPS – Emergency Power System
- ESS – Energy Storage System
- E-Stop – Emergency Stop
- FCC – Federal Communication Commission
- GE – Grounding Electrode
- GEC – Grounding Electrode Conductor
- GFCI – Ground Fault Circuit Interrupter
- GFDI – Ground Fault Detector/Interrupter
- Imp – Maximum Power Point Current
- STC – Standard Testing Conditions
- UL – Underwriters Laboratories
- IEEE – Institute of Electrical and Electronic Engineers
- IP – Ingress Protection
- I_{sc} – Short-Circuit Current
- In-lbs. – Inch Pounds
- kW – Kilowatt
- kWh – Kilowatt-hour
- LCD – Liquid Crystal Display
- LFP – Lithium Iron Phosphate
- L1 – Line 1
- L2 – Line 2
- mm – Millimeters
- MPPT – Maximum Power Point Tracking
- mV – Millivolt
- N – Neutral
- NEC – National Electric Code
- NEMA – National Electrical Manufacturers Association
- NFPA – National Fire Prevention Association
- Nm – Newton Meters
- NOCT – Normal Operating Cell Temperature
- PC – Personal Computer
- PCB – Printed Circuit Board
- PE – Protective Earth
- PPE – Personal Protective Equipment
- PV – Photovoltaic
- RSD – Rapid Shut Down
- SCC – Standards Council of Canada
- SOC – State of Charge
- UPS – Uninterrupted Power Supply
- V – Volts

- VOC – Open-Circuit Voltage
- VMP – Voltage Maximum Power

INTERNAL USE ONLY
INFORMATION SUBJECT TO
CHANGE WITHOUT NOTICE

NOTES:

INTERNAL USE ONLY
INFORMATION SUBJECT TO
CHANGE WITHOUT NOTICE