

Table of Contents

Table of Contents.....1

SAFETY INSTRUCTIONS.....2

WARNING3

CAUTION.....4

1. Product Overview.....5

2. Before using the product.....5

3. Installation Procedure.....5

4. H100 Product Size (Drive with Conduit Option)14

5. Dimensions & Screw.....25

6. Revision History.....26

Thank you for purchasing LS Variable Frequency Drives!

SAFETY INSTRUCTIONS

To prevent injury and property damage, follow these instructions. Incorrect operation due to ignoring instructions will cause harm or damage. The seriousness of which is indicated by the following symbols.



DANGER

This symbol indicates the instant death or serious injury if you don't follow instructions



WARNING

This symbol indicates the possibility of death or serious injury



CAUTION

This symbol indicates the possibility of injury or damage to property

- The meaning of each symbol in this manual and on your equipment is as follows.



This is the safety alert symbol.

Read and follow instructions carefully to avoid dangerous situation.



This symbol alerts the user to the presence of "dangerous voltage" inside the product that might cause harm or electric shock.

- After reading this manual, keep it in the place that the user always can find easily.
- This manual should be given to the person who actually uses the products and is responsible for their maintenance.



WARNING

- **Do not remove the cover while power is applied or the unit is in operation.**
Otherwise, electric shock could occur.
- **Do not run the inverter with the front cover removed.**
Otherwise, you may get an electric shock due to high voltage terminals or charged capacitor exposure.
- **Do not remove the cover except for periodic inspections or wiring, even if the input power is not applied.**
Otherwise, you may access the charged circuits and get an electric shock.
- **Wiring and periodic inspections should be performed at least 10 minutes after disconnecting the input power and after checking the DC link voltage is discharged with a meter (below DC 30V).**
Otherwise, you may get an electric shock.
- **Operate switches with dry hands.**
Otherwise, you may get an electric shock.
- **Do not use the cable when its insulation is damaged.**
Otherwise, you may get an electric shock.
- **Do not subject the cables to scratches, excessive stress, heavy loads or pinching.**
Otherwise, you may get an electric shock.



CAUTION

- **Install the inverter on a non-flammable surface. Do not place flammable material nearby.**

Otherwise, fire could occur.

- **Disconnect the input power if the inverter gets damaged.**

Otherwise, it could result in a secondary accident and fire.

- **Do not touch the inverter while the input power is applied or after removed. It will remain hot for a couple of minutes.**

Otherwise, you may get bodily injuries such as skin-burn or damage.

- **Do not apply power to a damaged inverter or to an inverter with parts missing even if the installation is complete.**

Otherwise, electric shock could occur.

- **Do not allow lint, paper, wood chips, dust, metallic chips or other foreign matter into the drive.**

Otherwise, fire or accident could occur.

OPERATING PRECAUTIONS

- **Make sure the assembly to the specified torque, do not over tighten the screw to the specified torque.**

Otherwise, it could result in product damage.

1. Product Overview

This installation guide is applied to the LSLV – H100 drive series Conduit Option..

2. Before using the product

Perform the following tasks after receiving the conduit option.

- ◆ Inspect the conduit option for damage.
If the conduit option appears damaged upon receipt, contact the shipper immediately.

- ◆ Check the label of model whether it is as same as the model number printed on the package of the conduit option.

3. Installation Procedure

- ◆ Conduit Option Assembly and Installation Procedure

DANGER! Electrical Shock Hazard : Do not connect or disconnect wiring while the power is on. Failure to comply will result in death or serious injury.

Wiring and periodic inspections should be performed at least 10 minutes after disconnecting the input power

And after checking the DC link voltage is discharged with a meter (below DC 30V)

3.1 H100 0.8~30kW

- ① Remove the Power cover and cable guide of the product as shown in the Figure 1.

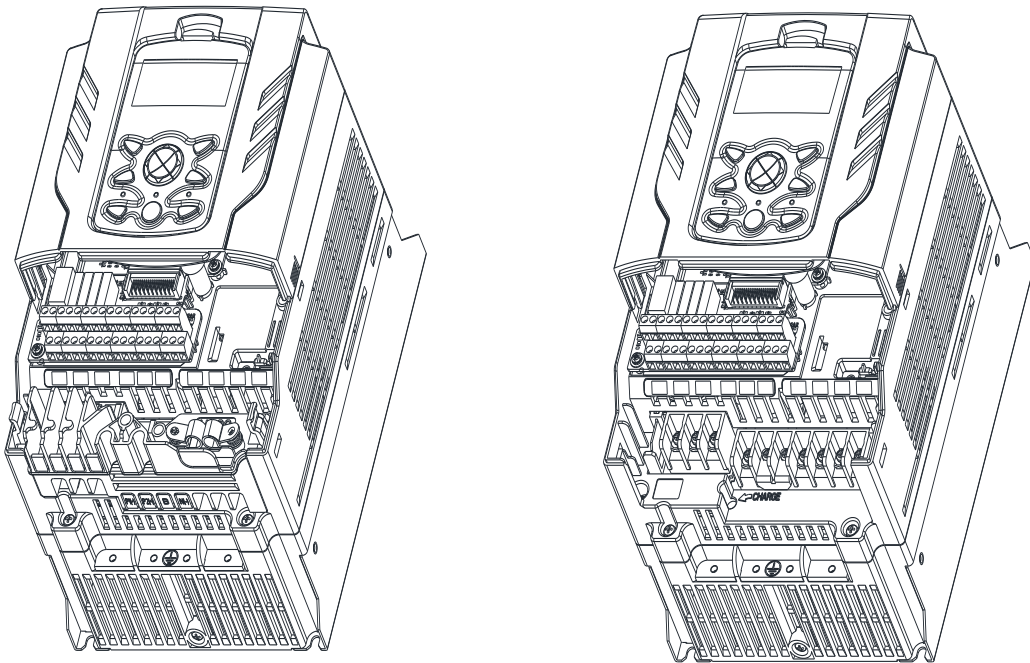

Figure 1. Remove Power Cover and CABLE Guide

- ② Fasten the Conduit Option to fit on the side of ground terminals of the product using the prescribed bolt as shown in the Figure 2.

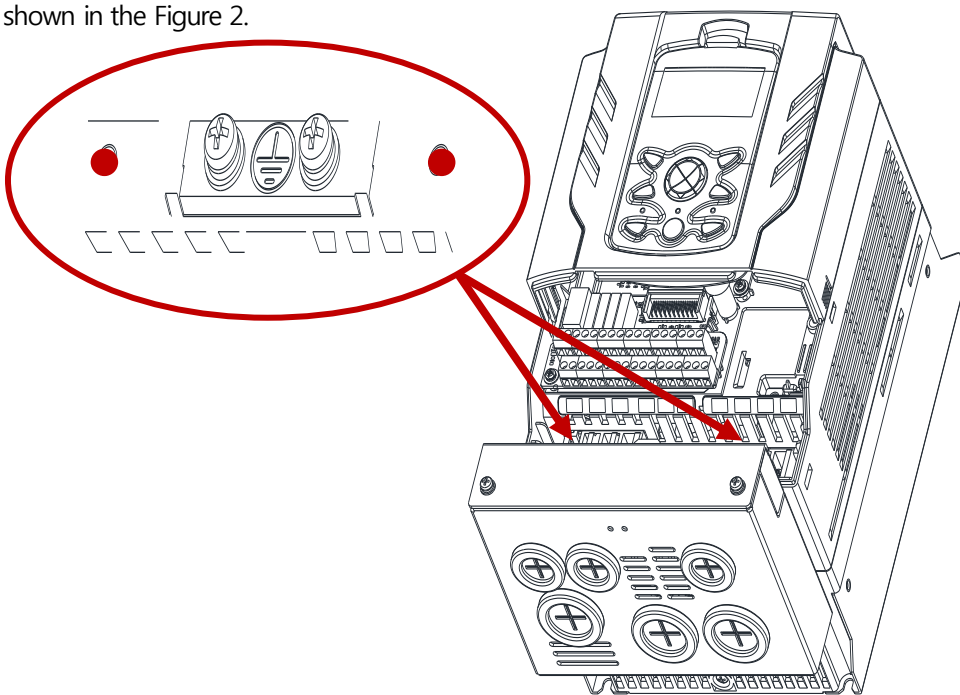

Figure 2. Install

- ③ Install the Power cover again.

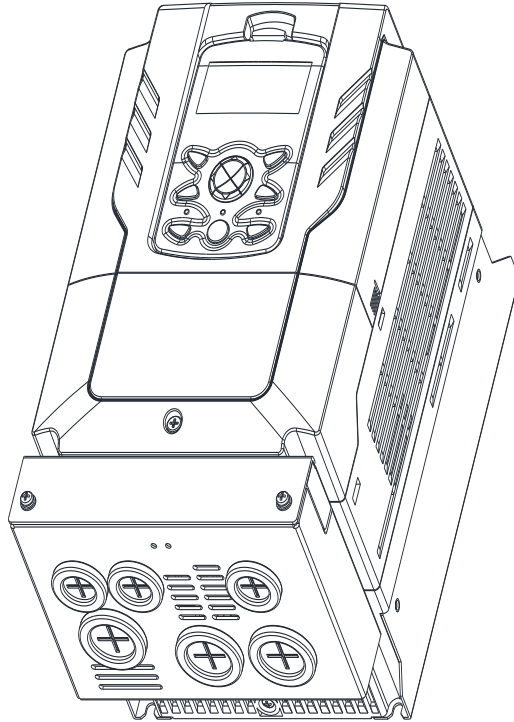

Figure 3. After installation

3.2 H100 37~90kW

- ① Remove the Power cover and cable guide of the product as shown in the Figure 4.

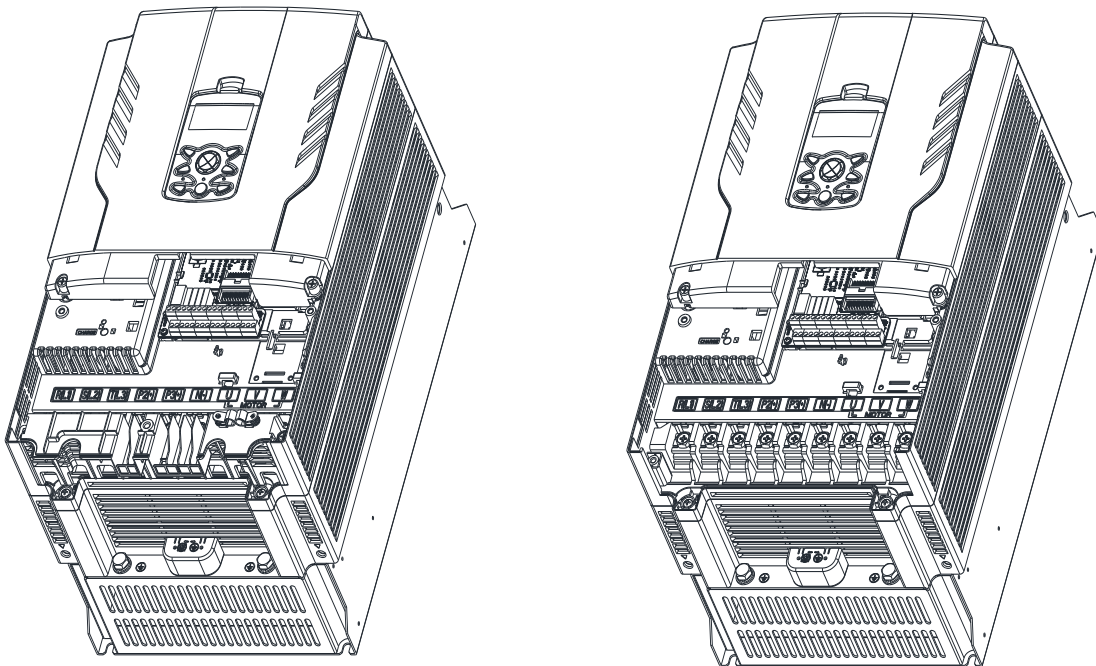

Figure 4. Remove Power Cover and CABLE Guide

- ② Fasten the Conduit Option to fit on the ground terminals and both ends (4points) of the product using the prescribed bolt as shown in the Figure 5.

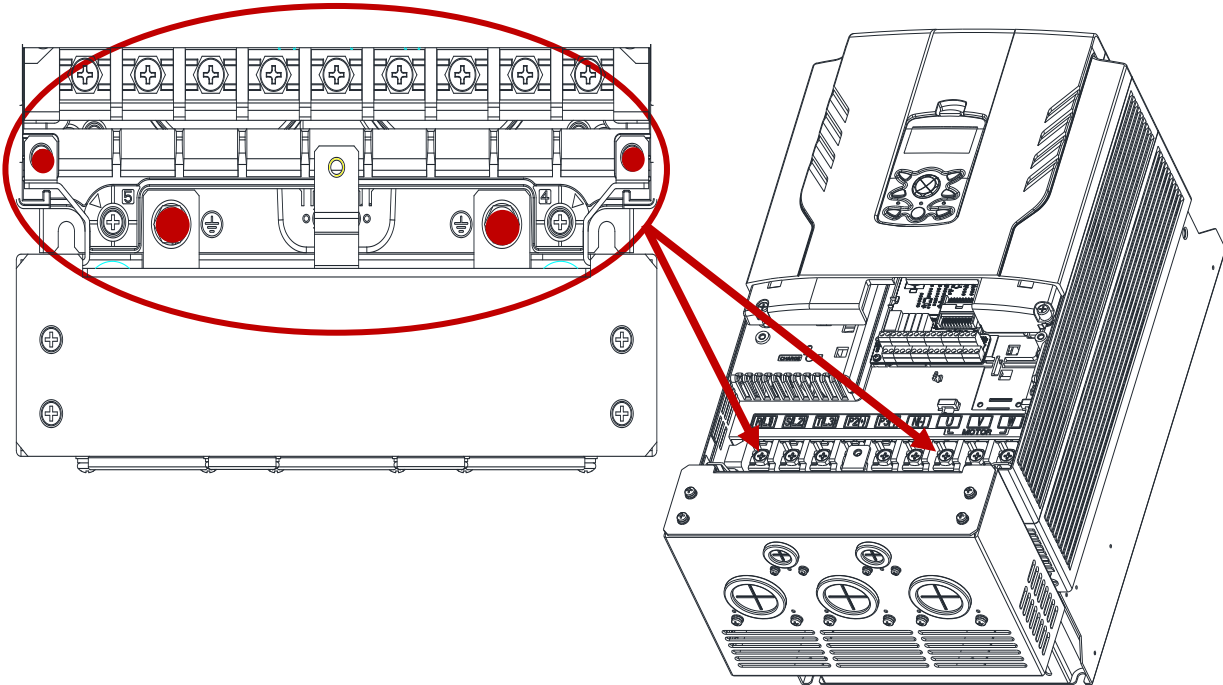

Figure 5. Install

- ③ Install the Power cover again.

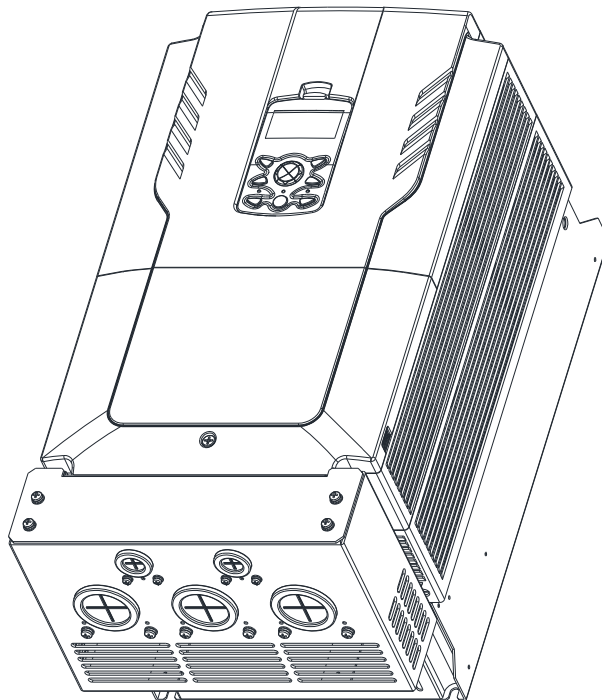

Figure 6. After installation

3.3 H100 110~185kW

- ① Remove the Power cover and cable guide of the product as shown in the Figure 7.

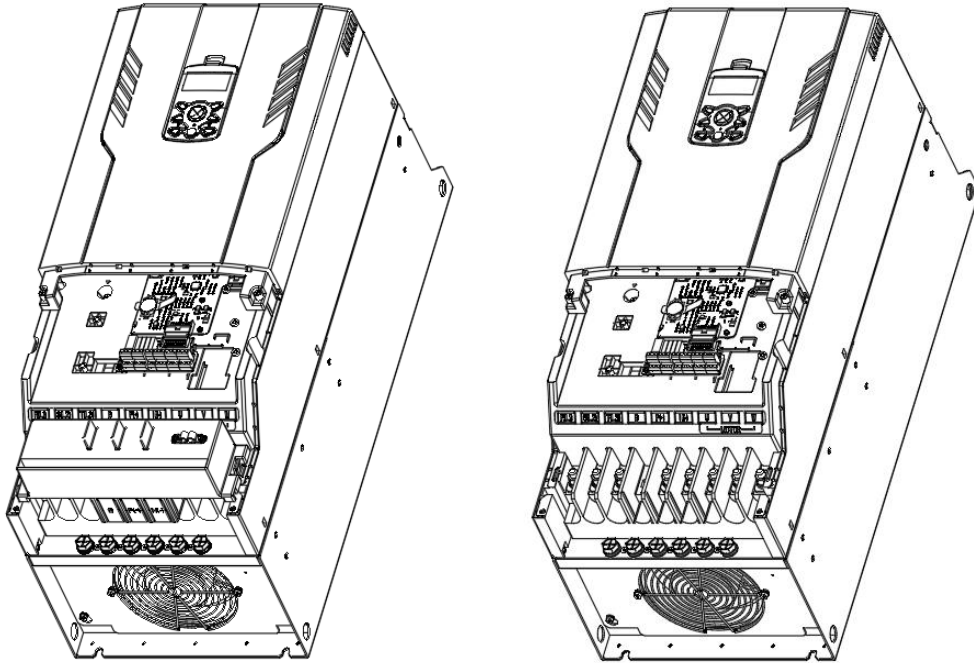

Figure 7. Remove Power Cover and CABLE Guide

- ② Fasten the Conduit Option to fit on the side of ground terminals of the product using the prescribed bolt as shown in the Figure 8.

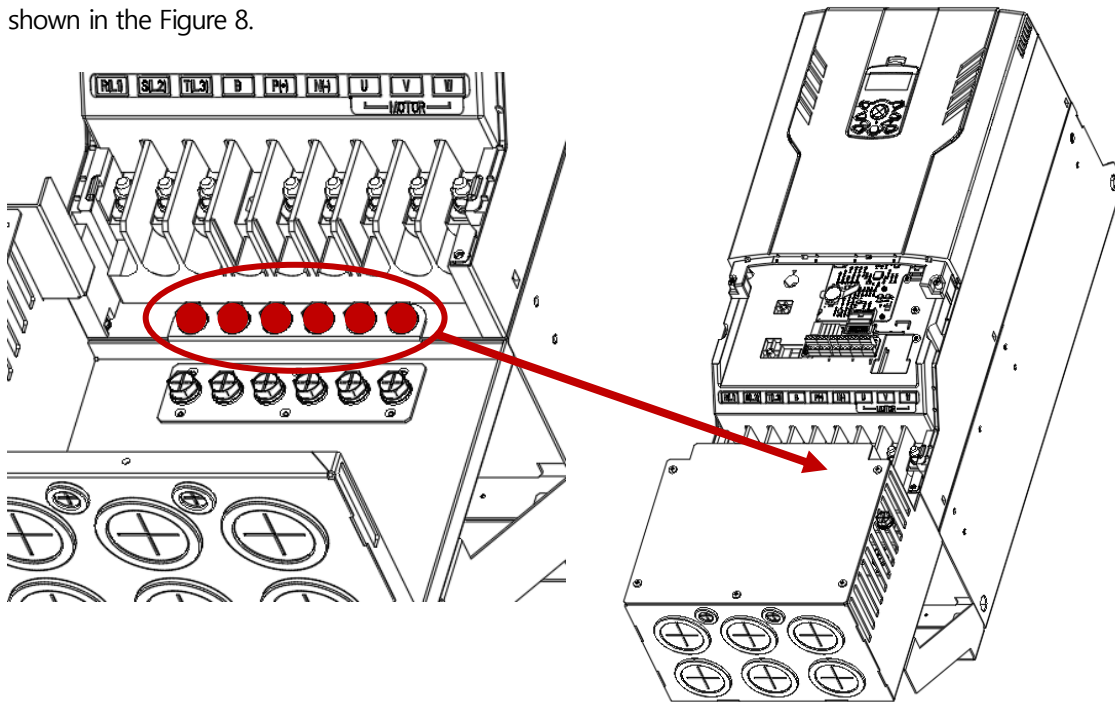

Figure 8. Install

- ③ Install the Power cover again.

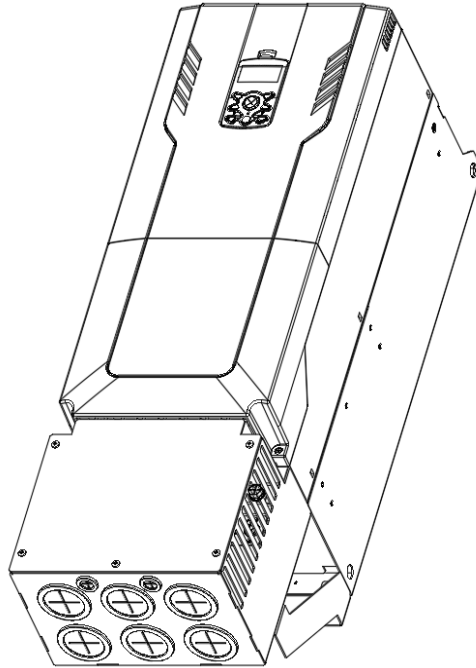

Figure 9. After installation

3.3 H100 220~250kW

- ① Remove the Power cover and Front cover of the product as shown in the Figure 10.

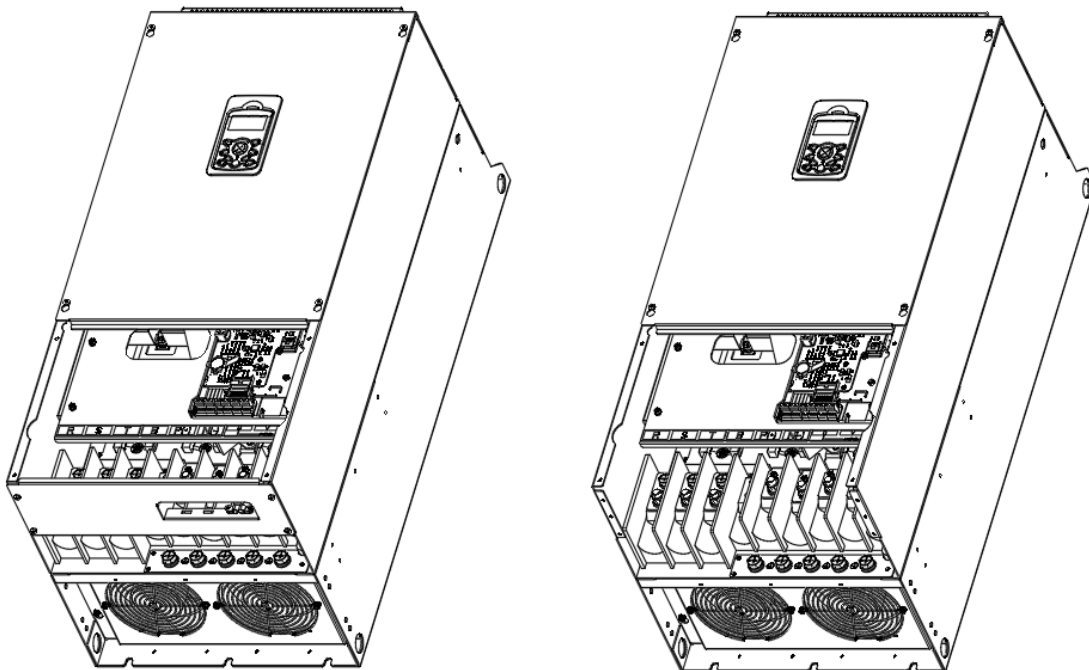

Figure 10. Remove Power Cover and Front cover

- ② Fasten the Conduit Option to fit on the side of ground terminals of the product using the prescribed bolt as shown in the Figure 11.

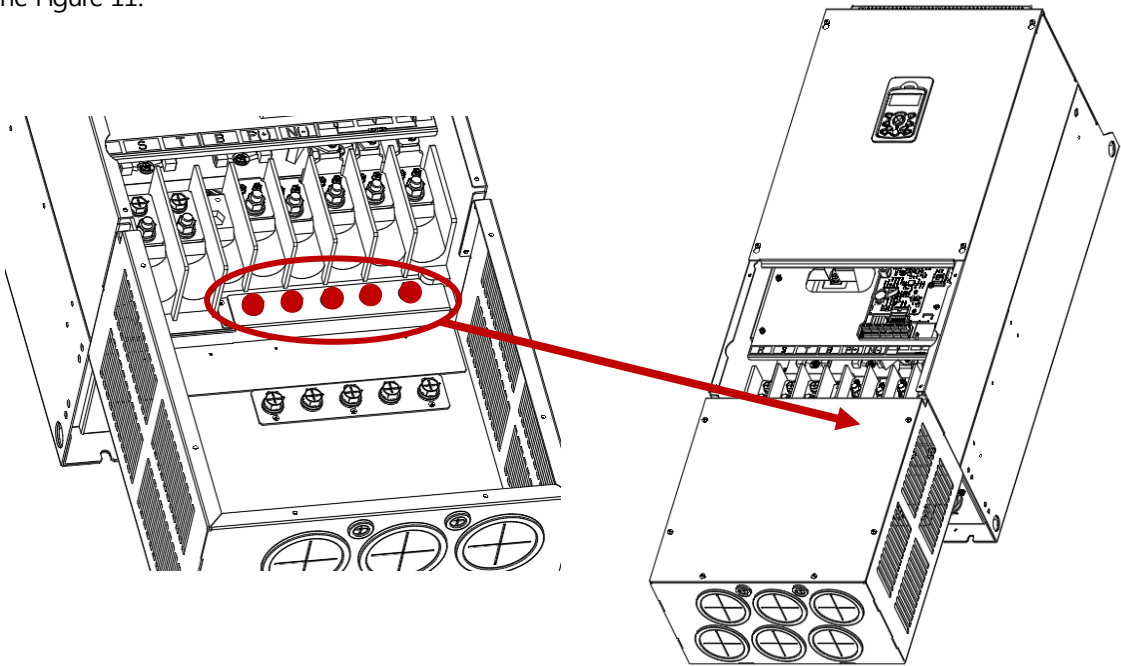

Figure 11. Install

- ③ Install the Power cover again.

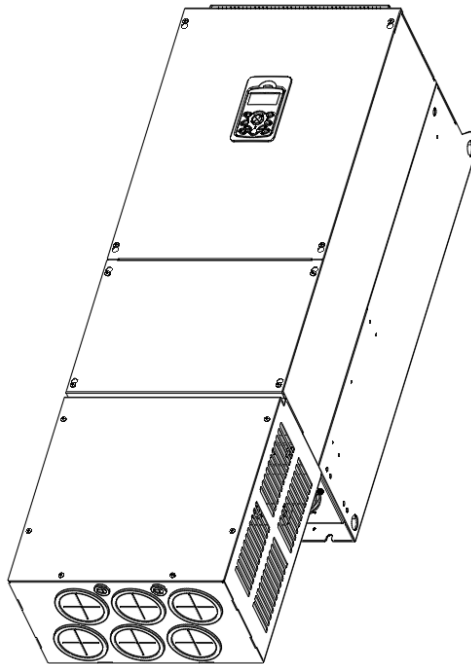

Figure 12. After installation

3.4 H100 315~500kW

- ① Remove the Power cover and Front cover of the product as shown in the Figure 13.

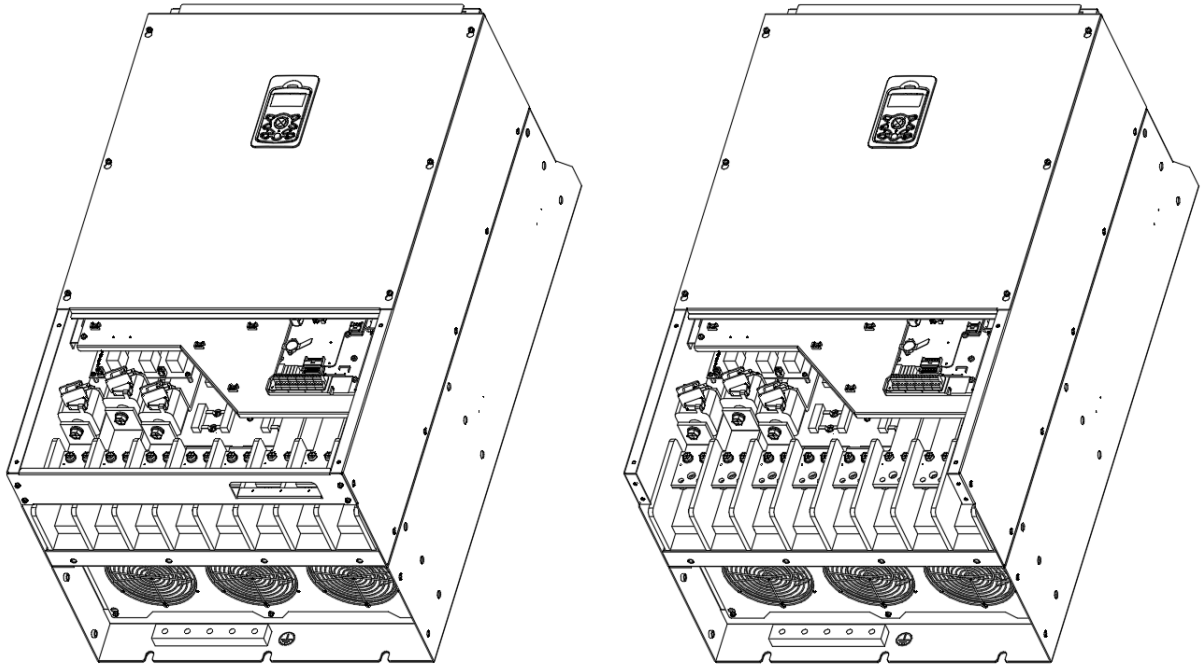

Figure 13. Remove Power Cover and Front cover

- ② Fasten the Conduit Option to fit on the side of ground terminals of the product using the prescribed bolt as shown in the Figure 14.

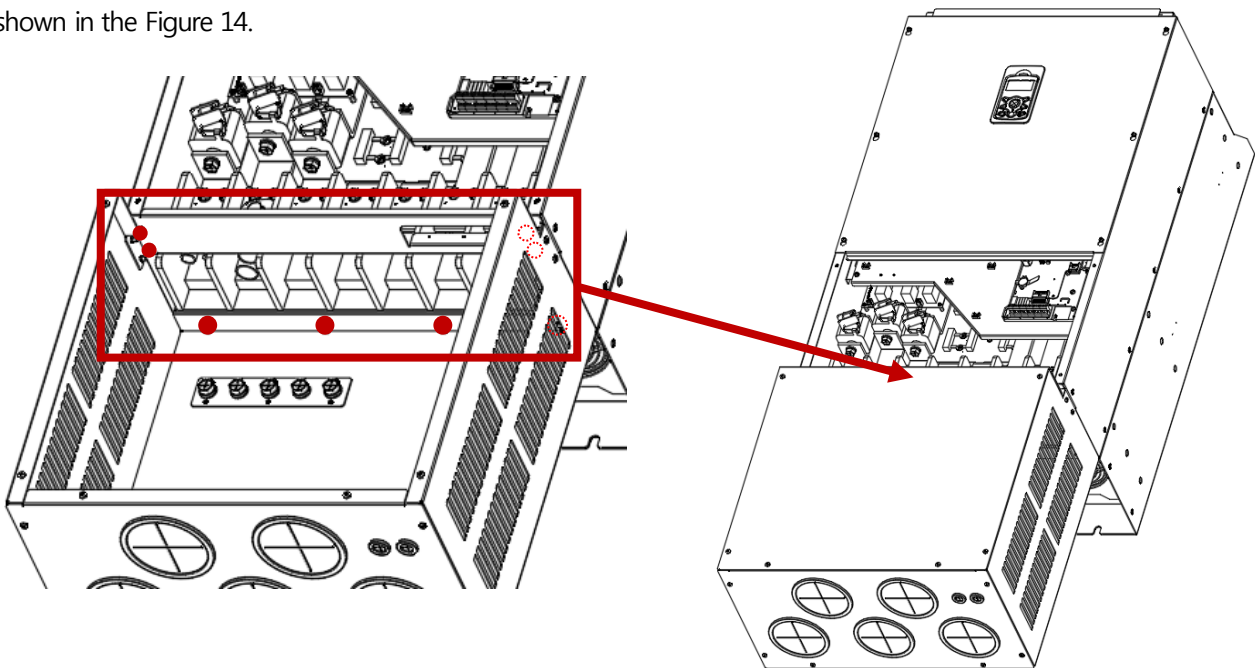

Figure 14. Install

- ③ Install the Power cover again.

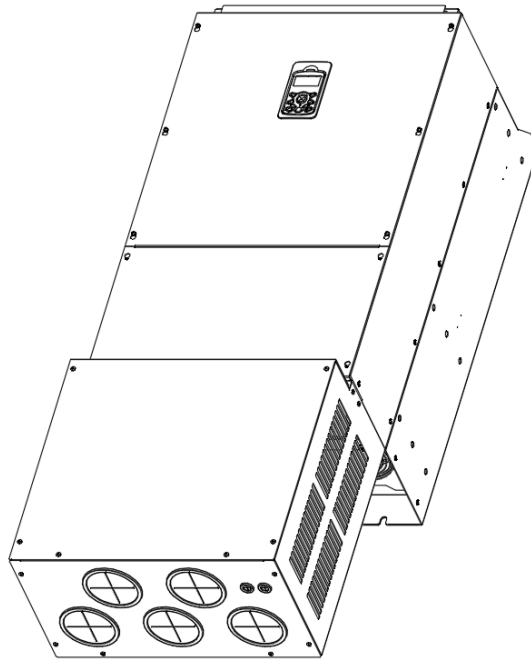
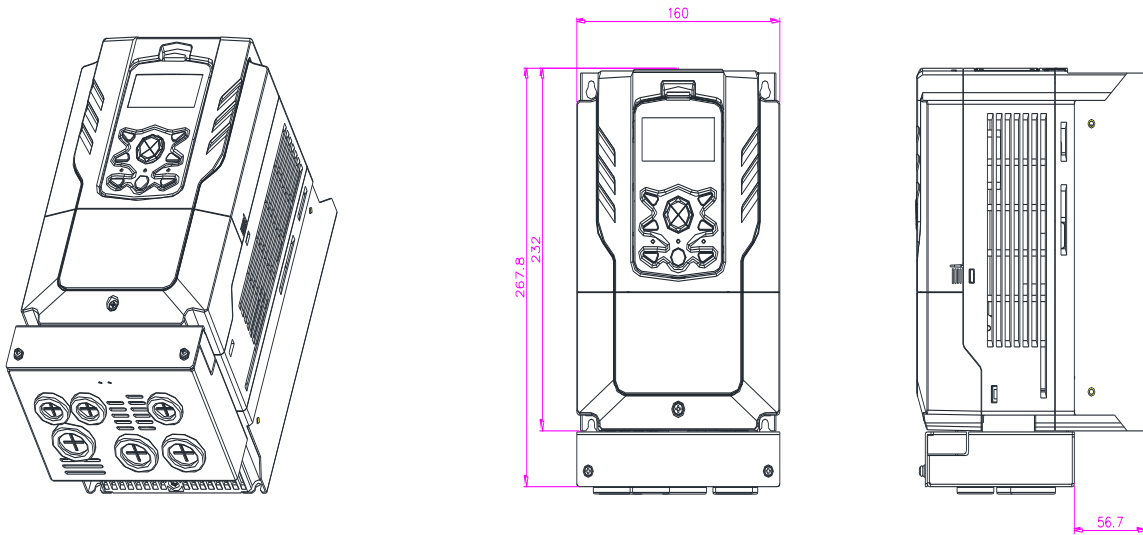

Figure 15. After installation

4. H100 Product Size (Drive with Conduit Option)

LSLV H100 0.8~11kW – 2/4



Drive + Conduit

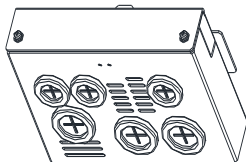
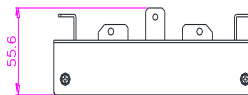
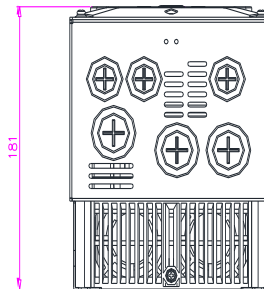

Conduit

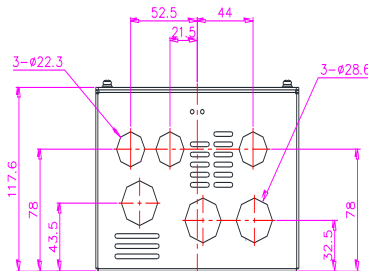

LSLV H100 15kW – 2/4, 18.5kW – 4

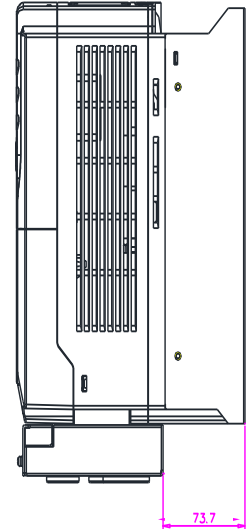
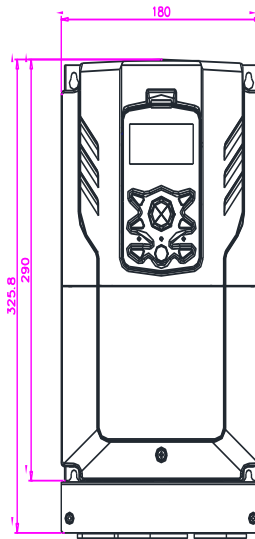
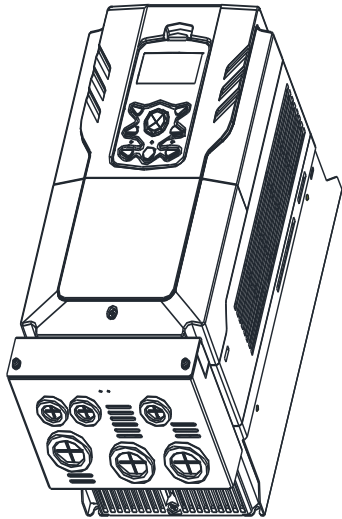

Drive + Conduit

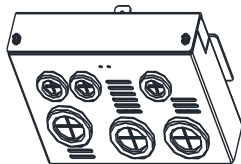
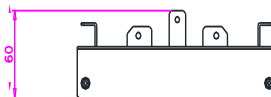
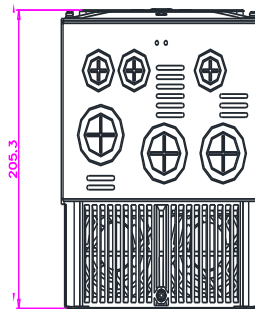

Conduit

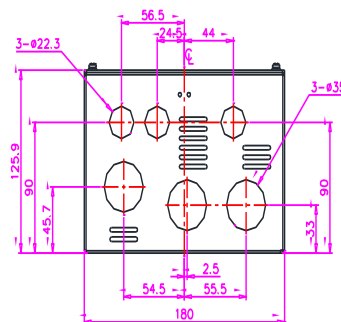

LSLV H100 18.5kW – 2, 22~30kW – 4

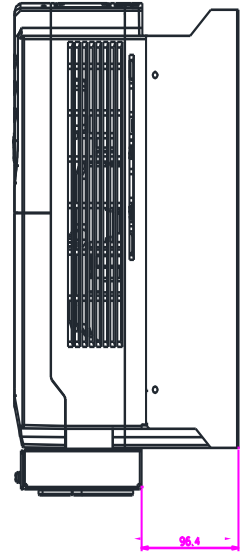
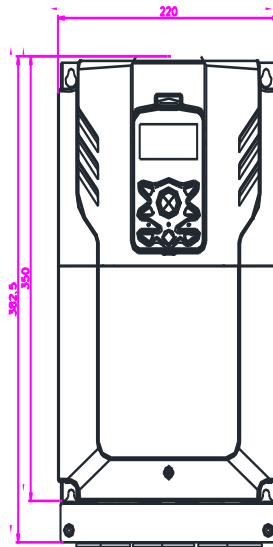
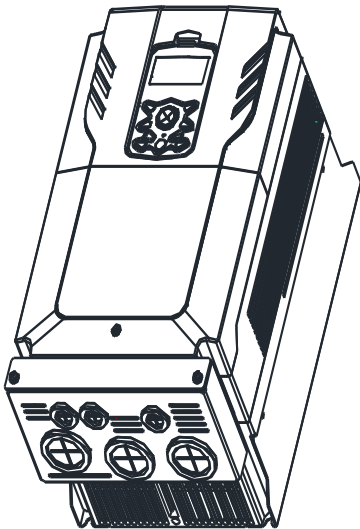

Drive + Conduit

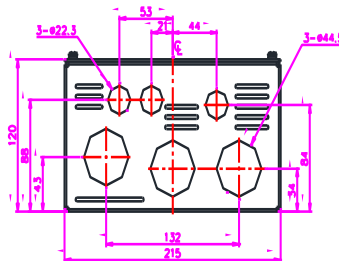
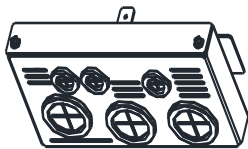
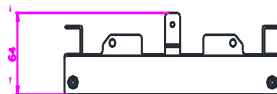
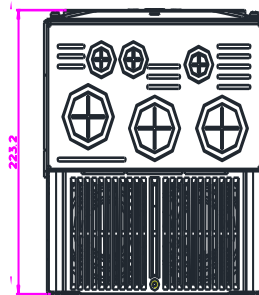

Conduit

LSLV H100 37kW – 4

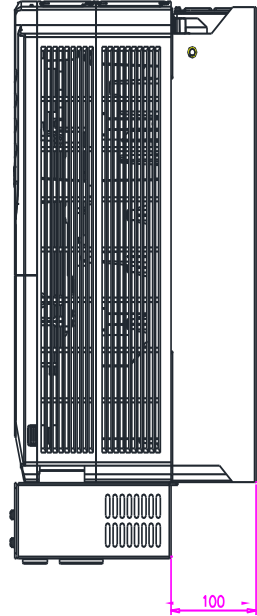
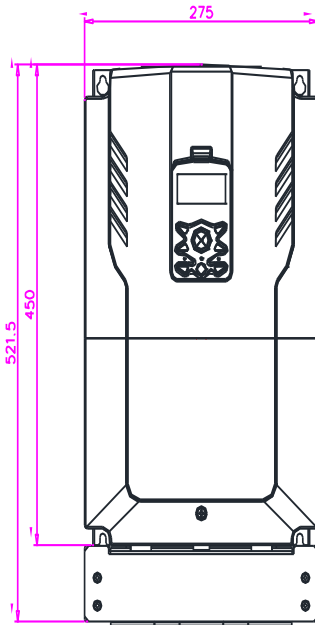
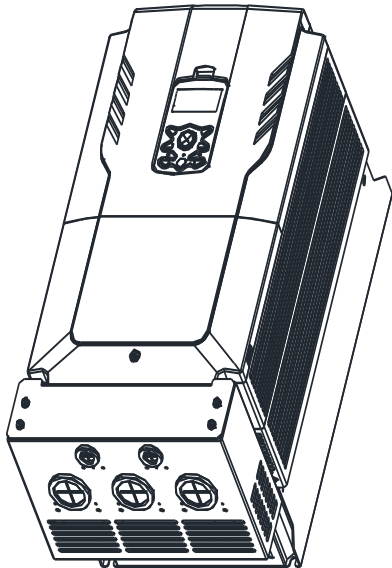

Drive + Conduit

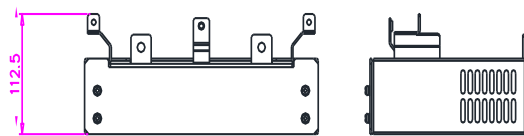
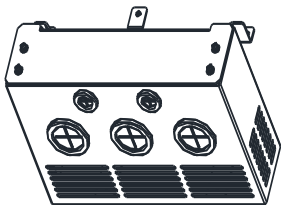
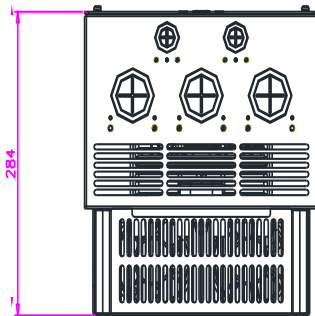

Conduit

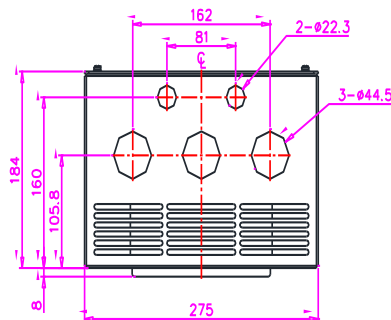

LSLV H100 45~55kW – 4

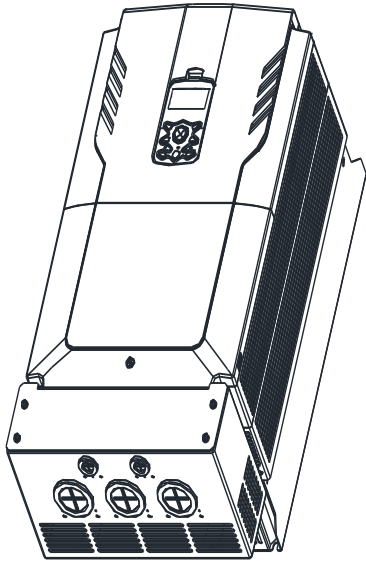

Drive + Conduit

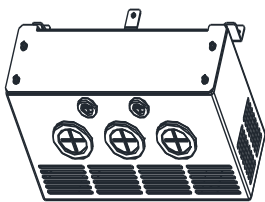
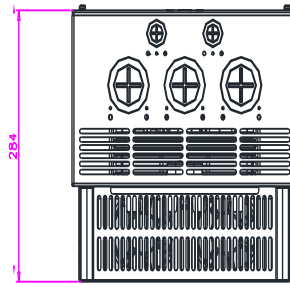
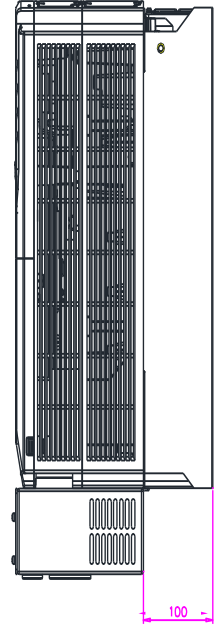
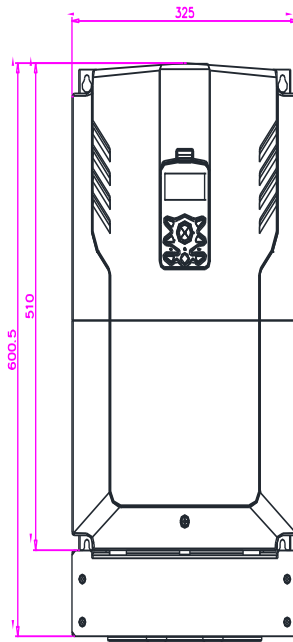

Conduit

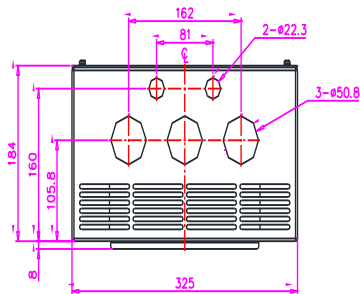
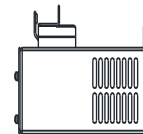
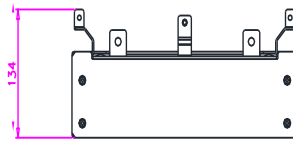

LSLV H100 75~90kW – 4

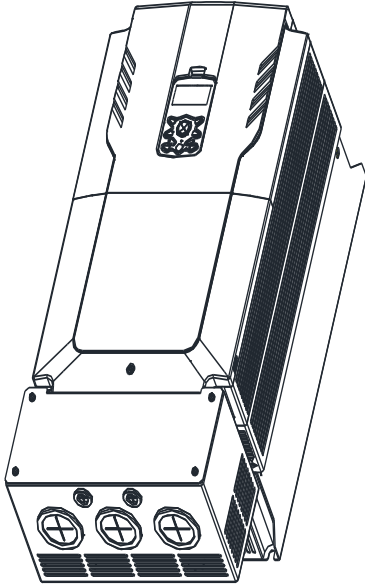

Drive + Conduit

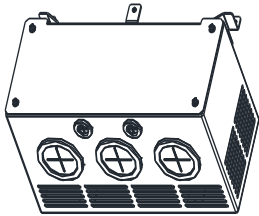
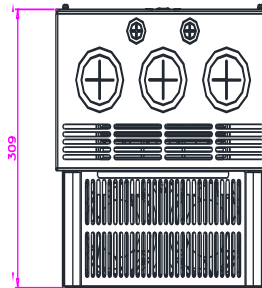
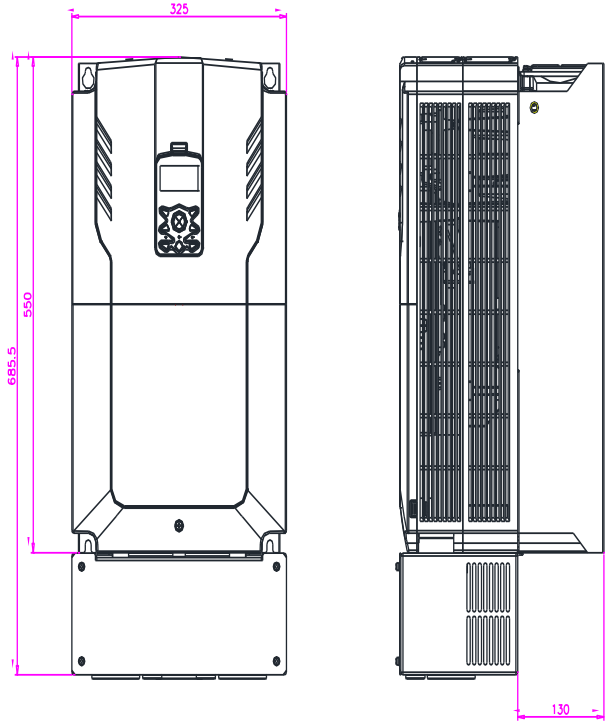

Conduit

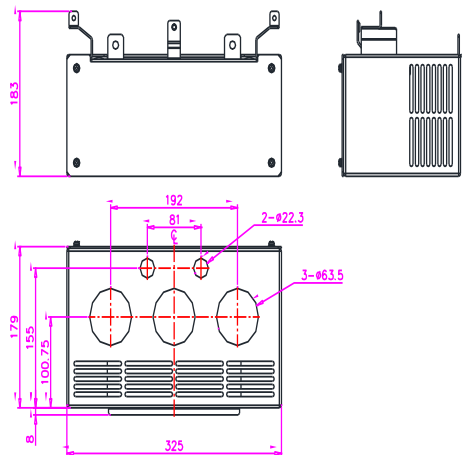

LSLV H100 110~132kW – 4

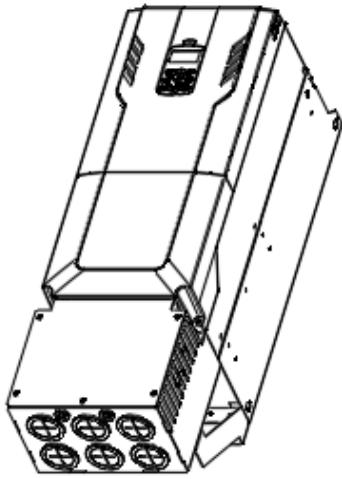

Drive + Conduit

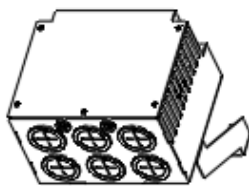
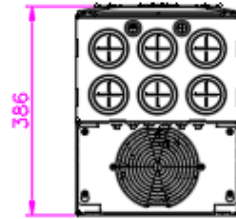
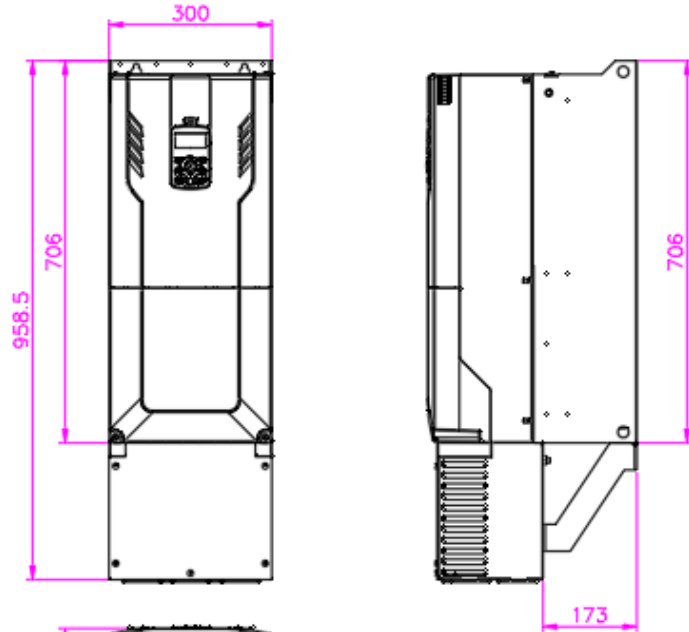

Conduit

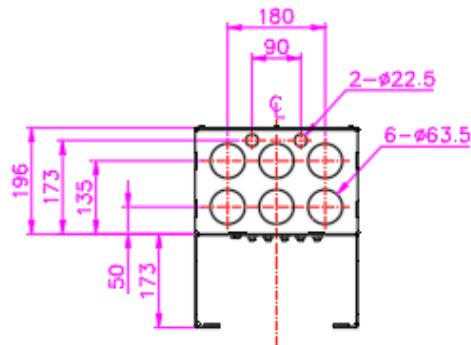
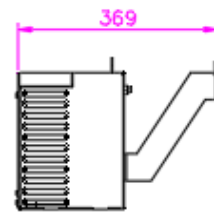
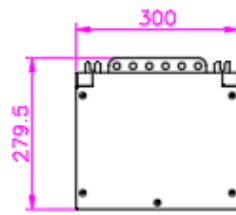

LSLV H100 160~185kW – 4

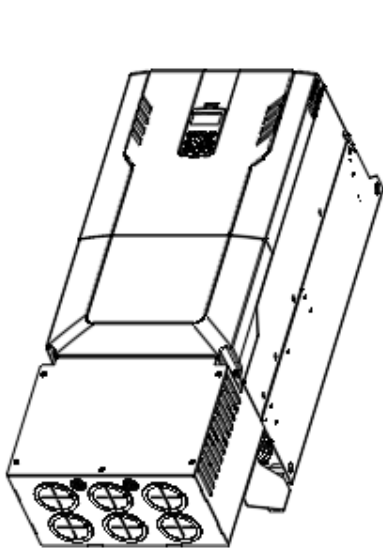

Drive + Conduit

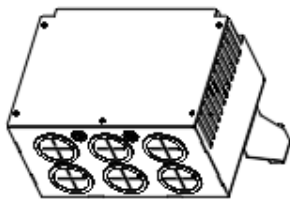
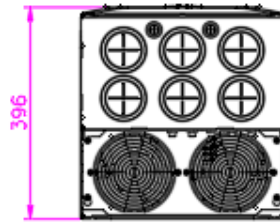
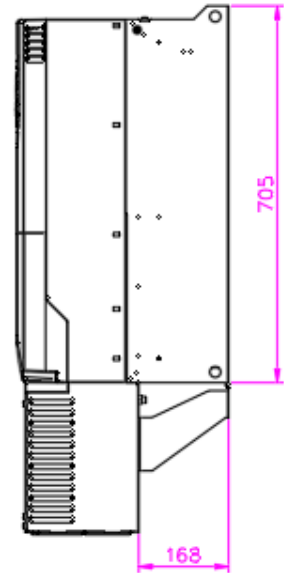
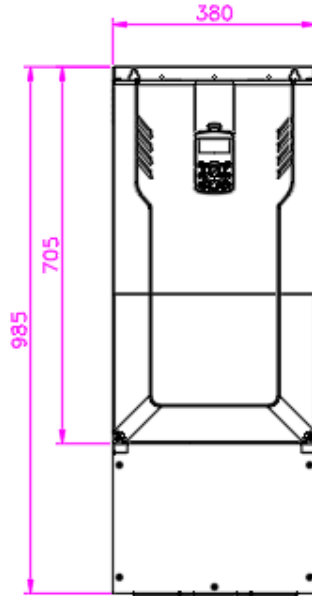

Conduit

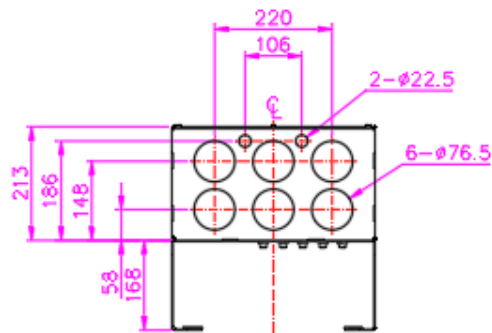
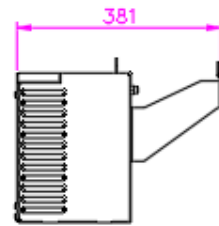
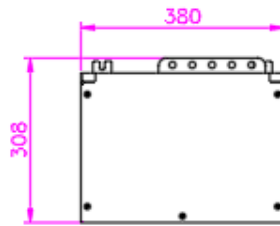

LSLV H100 220~250kW – 4

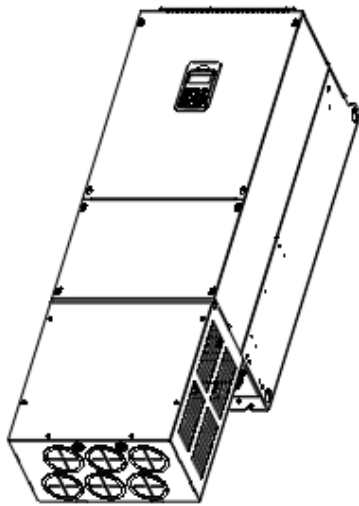

Drive + Conduit

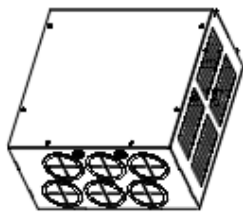
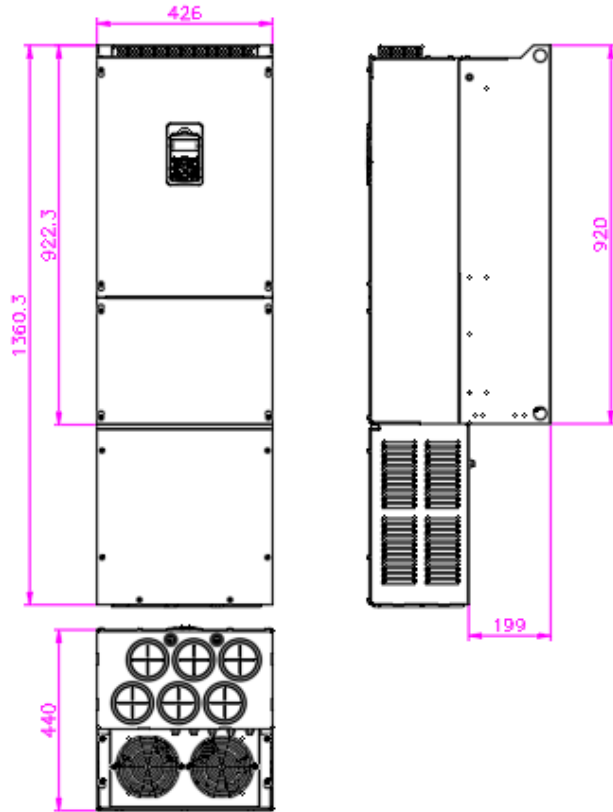

Conduit

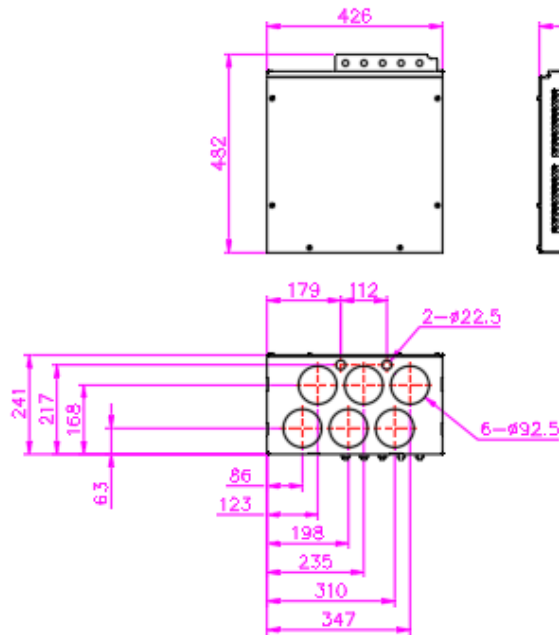

LSLV H100 315~400kW – 4

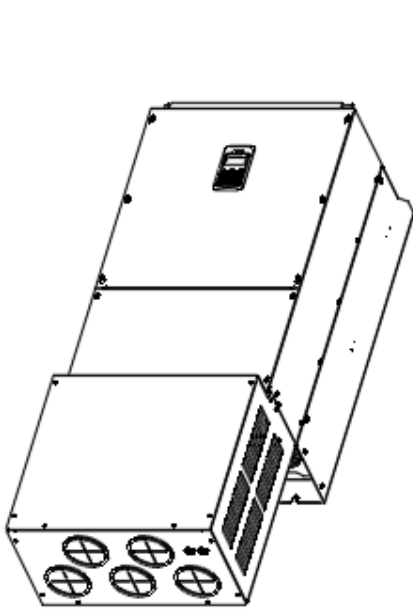

Drive + Conduit

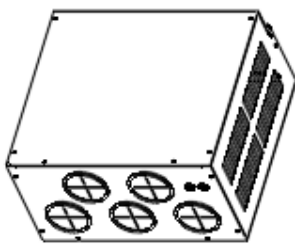
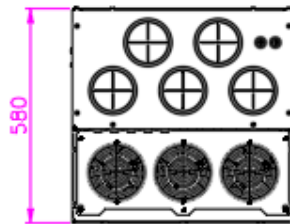
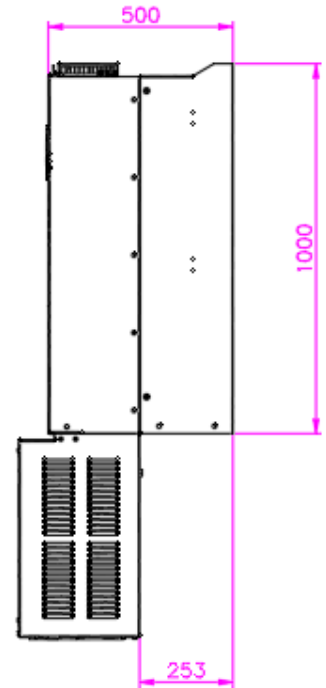
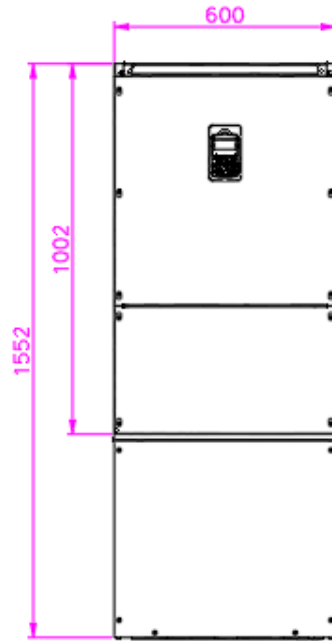

Conduit

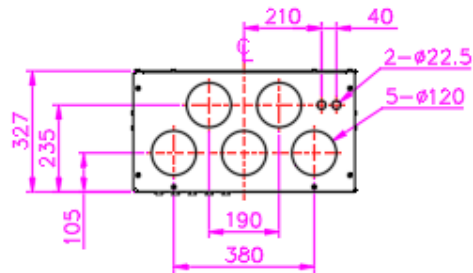
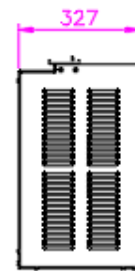
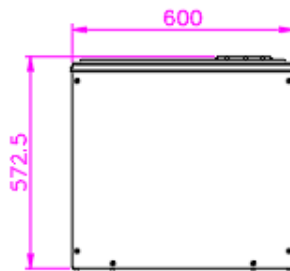

LSLV H100 500kW – 4

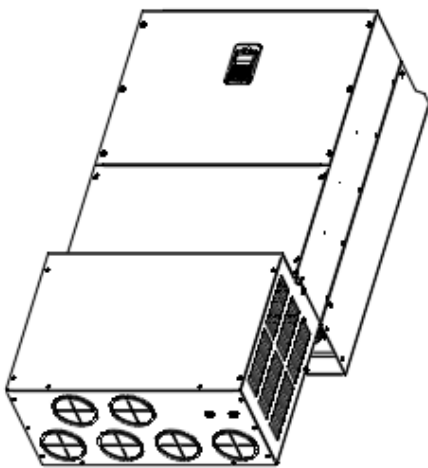

Drive + Conduit

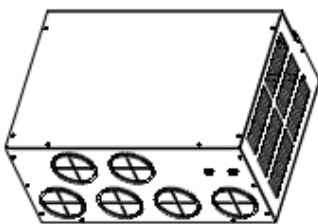
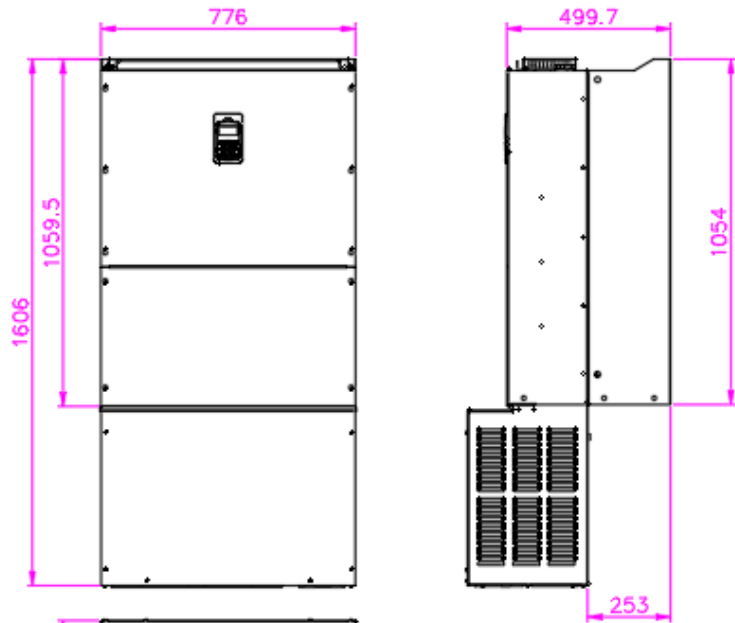

Conduit

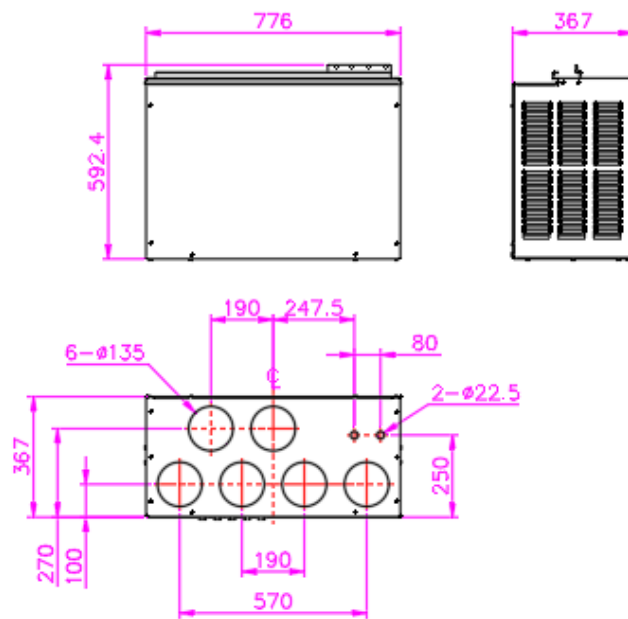

5. Dimensions & Screw

Product - capacity	W1	H1	D1	Terminal Screw Size	Screw Torque (Kgf-cm/Nm)
0008H100-2/4 0015H100-2/4 0022H100-2/4 0037H100-2/4 0055H100-2/4 0075H100-2/4 0110H100-2/4	160 (6.30)	117.6 (4.63)	55.6 (2.18)	M4	2.1~6.1/0.2~0.6
0150H100-2/4 0185H100-4	180 (7.08)	125.9 (4.95)	60 (2.36)	M5	4.0~10.2/0.4~1.0
0185H100-2 0220H100-4 0300H100-4	215 (8.46)	120 (4.72)	64 (2.52)		
0370H100-4	275 (1.08)	184 (7.24)	112.5 (4.43)	M8	61.2~91.8/6.1~9.2
0450H100-4 0550H100-4	325 (12.79)	184 (7.24)	134 (5.27)		
0750H100-4 0900H100-4	325 (12.79)	179 (7.05)	183 (7.20)		
1100H100-4 1320H100-4	300 (11.81)	369 (14.53)	279.5 (11.00)		
1600H100-4 1850H100-4	380 (14.96)	381 (15.00)	308 (12.13)	M12	182.4~215.0/17.87~21.07
2200H100-4 2500H100-4	426 (16.77)	241 (9.49)	482 (18.98)		
3150H100-4 3550H100-4 4000H100-4	600 (23.62)	327 (12.87)	572.5 (22.54)		
5000H100-4	776 (30.55)	367 (14.45)	592.4 (23.32)		

W,H,D Units : mm(inches)

6. Revision History

No	Date	Editioin	Changes
1	2018.09	First Edition	-