

**(en) Electric current! Danger to life!**  
Only skilled or instructed persons may carry out the following operations.

**(de) Lebensgefahr durch elektrischen Strom!**  
Nur Elektrofachkräfte und elektrotechnisch unterwiesene Personen dürfen die im Folgenden beschriebenen Arbeiten ausführen.

**(fr) Tension électrique dangereuse !**  
Seules les personnes qualifiées et averties doivent exécuter les travaux ci-après.

**(es) ¡Corriente eléctrica! ¡Peligro de muerte!**  
El trabajo a continuación descrito debe ser realizado por personas cualificadas y advertidas.

**(it) Tensione elettrica: Pericolo di morte!**  
Solo persone abilitate e qualificate possono eseguire le operazioni di seguito riportate.

**(zh) 触电危险!**  
只允许专业人员和受过专业训练的人员进行下列工作。

**(ru) Электрический ток! Опасно для жизни!**  
Только специалисты или проинструктированные лица могут выполнять следующие операции.

**(nl) Levensgevaar door elektrische stroom!**  
Uitsluitend deskundigen in elektriciteit en elektrotechnisch geïnstrueerde personen is het toegestaan, de navolgend beschreven werkzaamheden uit te voeren.

**(da) Livsfare på grund af elektrisk strøm!**  
Kun uddannede el-installatører og personer der er instruerede i elektrotekniske arbejdsopgaver, må udføre de nedenfor anførte arbejder.

**(el) Προσοχή, κίνδυνος ηλεκτροπληξίας!**  
Οι εργασίες που αναφέρονται στη συνέχεια θα πρέπει να εκτελούνται μόνο από ηλεκτρολόγους και ηλεκτροτεχνίτες.

**(pt) Perigo de vida devido a corrente eléctrica!**  
Apenas electricistas e pessoas com formação electrotécnica podem executar os trabalhos que a seguir se descrevem.

**(sv) Livsfara genom elektrisk ström!**  
Endast utbildade elektriker och personer som undervisats i elektroteknik får utföra de arbeten som beskrivs nedan.

**(fi) Hengenvaarallinen jännite!**  
Vain pätevät sähköasentajat ja opastusta saaneet henkilöt saavat suorittaa seuraavat työt.

**(cs) Nebezpečí úrazu elektrickým proudem!**  
Níže uvedené práce smějí provádět pouze osoby s elektrotechnickým vzděláním.

**(et) Eluhtlik! Elektrilöögiolt!**  
Järgnevalt kirjeldatud töid tohib teostada ainult elektriala spetsialist või elektrotehnilise instrueerimise läbinud personal.

**(hu) Életveszély az elektromos áram révén!**  
Csak elektromos szakemberek és elektrotechnikában képzett személyek végezhetik el a következőkben leírt munkákat.

**(lv) Elektriskā strāva apdraud dzīvību!**  
Tālāk aprakstītos darbus drīkst veikt tikai elektrospeciālisti un darbam ar elektrotehnikām iekārtām instruētās personas!

**(lt) Pavojus gyvybei dėl elektros srovės!**  
Tik elektrikai ir elektrotechnikos specialistai gali atlikti žemiau aprašytus darbus.

**(pl) Porażenie prądem elektrycznym stanowi zagrożenie dla życia!**  
Opisane poniżej prace mogą przeprowadzać tylko wykwalifikowani elektrycy oraz osoby odpowiednio poinstruowane w zakresie elektrotechniki.

**(sl) Življenjska nevarnost zaradi električnega toka!**  
Spodaj opisana dela smejo izvajati samo elektrostrokovnjaki in elektrotehnično poučene osebe.

**(sk) Nebezpečnosť ohrozenia života elektrickým prúdom!**  
Práce, ktoré sú nižšie opísané, smú vykonávať iba elektroodborníci a osoby s elektrotechnickým vzdelaním.

**(bg) Опасност за живота от електрически ток!**  
Операциите, описани в следващите раздели, могат да се извършват само от специалисти-електротехници и инструктиран електротехнически персонал.

**(ro) Atenție! Pericol electric!**  
Toate lucrările descrise trebuie efectuate numai de personal de specialitate calificat și de persoane cu cunoștințe profunde în electrotehnică.

**(hr) Opasnost po život uslijed električne struje!**  
Radove opisane u nastavku smiju obavljati samo stručni električari i osobe koje su prošle elektrotehničku obuku.

## DA1-...-A20...

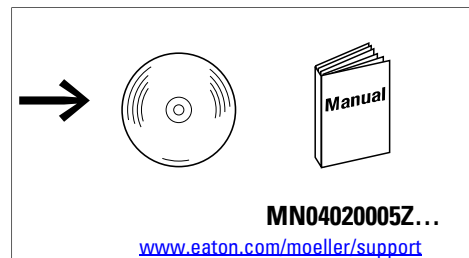
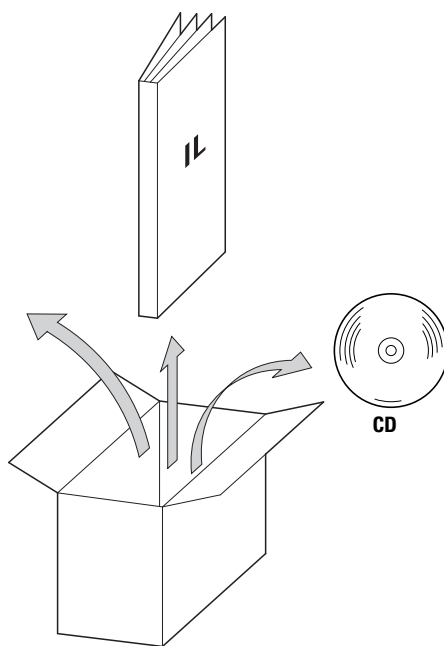
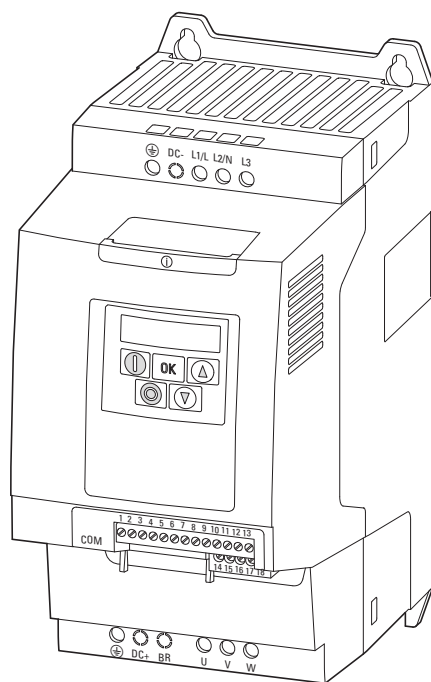

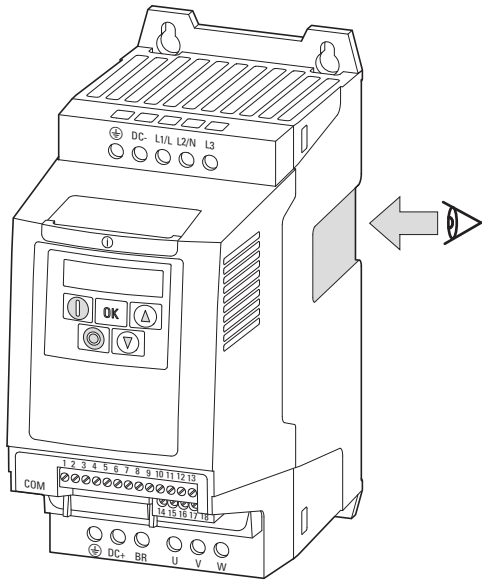

DA1-xy zzz FN - A20N

- 20 = IP20, NEMA 0
- B = Brake chopper (DC+, BR)
- N = No Brake chopper
- F = EMC Filter (RFI)
- N = No EMC Filter
- $I_e$
- 4D3 = 4.3 A
- 024 = 24 A
- $U_{LN}$  (Mains), 50/60 Hz
- 2 = 230 V (200 - 240 V  $\pm 10$  %)
- 4 = 400 V (380 - 480 V  $\pm 10$  %)
- Mains  $\rightarrow$  Motor
- 1 = 1 AC  $\rightarrow$  3 AC
- 3 = 3 AC  $\rightarrow$  3 AC

**Mains (TN, TT)**

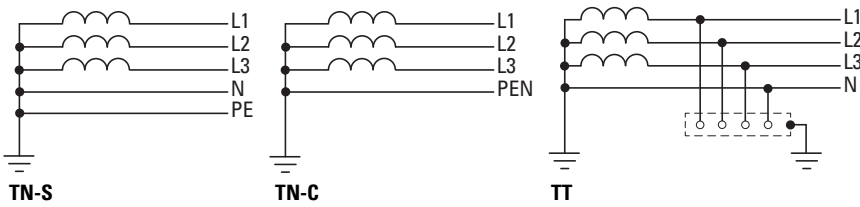

**DA1-12...**

Mains,  $U_{LN} = 1 \sim 200 - 240 \text{ V} \pm 10 \%$

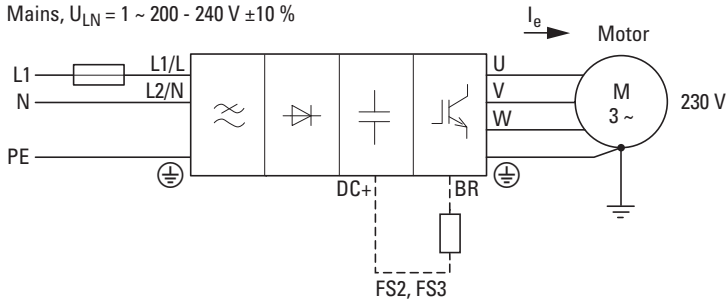

**DA1-32...**

Mains,  $U_{LN} = 3 \sim 200 - 240 \text{ V} \pm 10 \%$

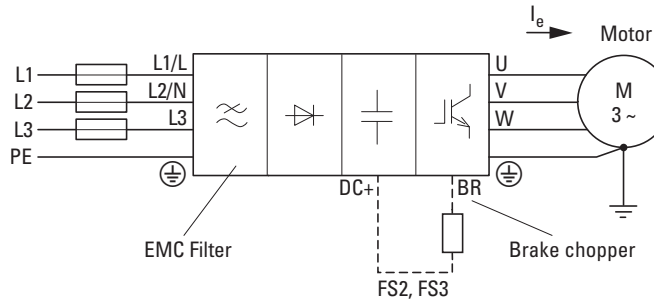

**DA1-34...**

Mains,  $U_{LN} = 3 \sim 380 - 480 \text{ V} \pm 10 \%$

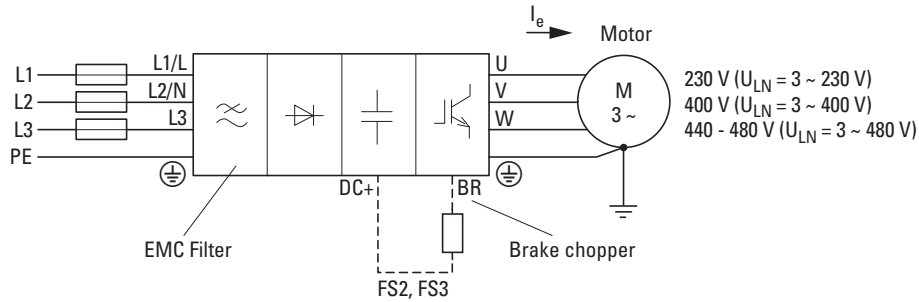

10/13 IL04020010Z

- |                                      |                                     |                                 |                                      |
|--------------------------------------|-------------------------------------|---------------------------------|--------------------------------------|
| (en) <b>Dimensions and weights</b>   | (ru) <b>Размеры и вес</b>           | (fi) <b>Mitat ja painot</b>     | (pl) <b>Wymiary i masy</b>           |
| (de) <b>Abmessungen und Gewichte</b> | (nl) <b>Afmetingen en gewichten</b> | (cs) <b>Rozměry a hmotnosti</b> | (sl) <b>Dimenzije in teže</b>        |
| (fr) <b>Encombremets et poids</b>    | (da) <b>Mål og vægt</b>             | (et) <b>Mõõtmed ja kaalud</b>   | (sk) <b>Rozmery a hmotnosti</b>      |
| (es) <b>Dimensiones y pesos</b>      | (el) <b>Διαστάσεις και βάρη</b>     | (hu) <b>Méreték és Súly</b>     | (bg) <b>Размери и тегло</b>          |
| (it) <b>Dimensioni e pesi</b>        | (pt) <b>Medições e pesos</b>        | (lv) <b>Izmēri un svārs</b>     | (ro) <b>Dimensiuni și greutateți</b> |
| (zh) <b>尺寸和重量</b>                    | (sv) <b>Dimensioner och vikter</b>  | (lt) <b>Matmenys ir svoriai</b> | (hr) <b>Dimenzije i težina</b>       |

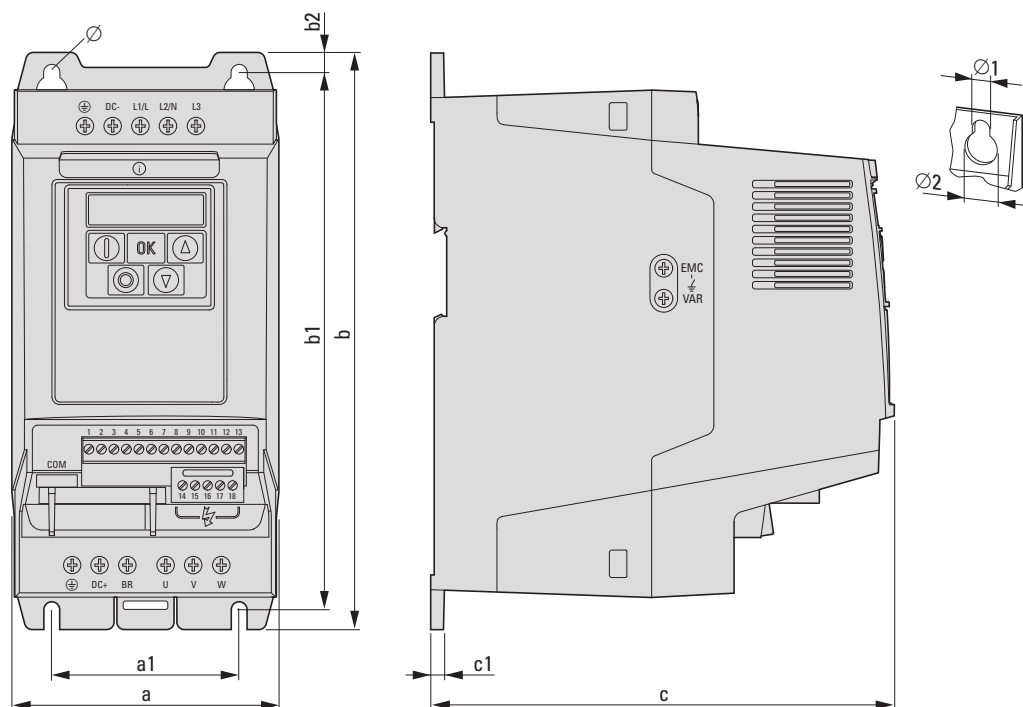

[mm (in)]

FS		a	a1	b	b1	b2	c	c1	Ø 1	Ø 2	kg (lbs)
FS2	DA1-12...	107 (4.21)	75 (2.95)	231 (9.09)	215 (8.46)	8 (0.31)	186 (7.32)	5 (0.2)	6 (0.24)	12 (0.47)	1.8 (3.97)
	DA1-32...										
	DA1-34...										
FS3	DA1-32...	131 (5.16)	100 (3.94)	273 (10.75)	255 (10.04)	8.5 (0.33)	204 (8.03)	5 (0.2)	6 (0.24)	12 (0.47)	3.5 (7.72)
	DA1-34...										

→ 1 inch = 25.4 mm  
1 mm = 0.0394 inch  
1 inch = 1"

- |                      |                       |                        |                          |                        |                      |
|----------------------|-----------------------|------------------------|--------------------------|------------------------|----------------------|
| (en) <b>Mounting</b> | (it) <b>Montaggio</b> | (da) <b>Montering</b>  | (fi) <b>Asennus</b>      | (lv) <b>Montāža</b>    | (sk) <b>Montáž</b>   |
| (de) <b>Montage</b>  | (zh) <b>安装</b>        | (el) <b>Τοποθέτηση</b> | (cs) <b>Montáž</b>       | (lt) <b>Montavimas</b> | (bg) <b>Монтаж</b>   |
| (fr) <b>Montage</b>  | (ru) <b>Монтаж</b>    | (pt) <b>Montagem</b>   | (et) <b>Paigaldamine</b> | (pl) <b>Montaż</b>     | (ro) <b>Montarea</b> |
| (es) <b>Montaje</b>  | (nl) <b>Montering</b> | (sv) <b>Montering</b>  | (hu) <b>Felszerelésé</b> | (sl) <b>Montaža</b>    | (hr) <b>Montaža</b>  |

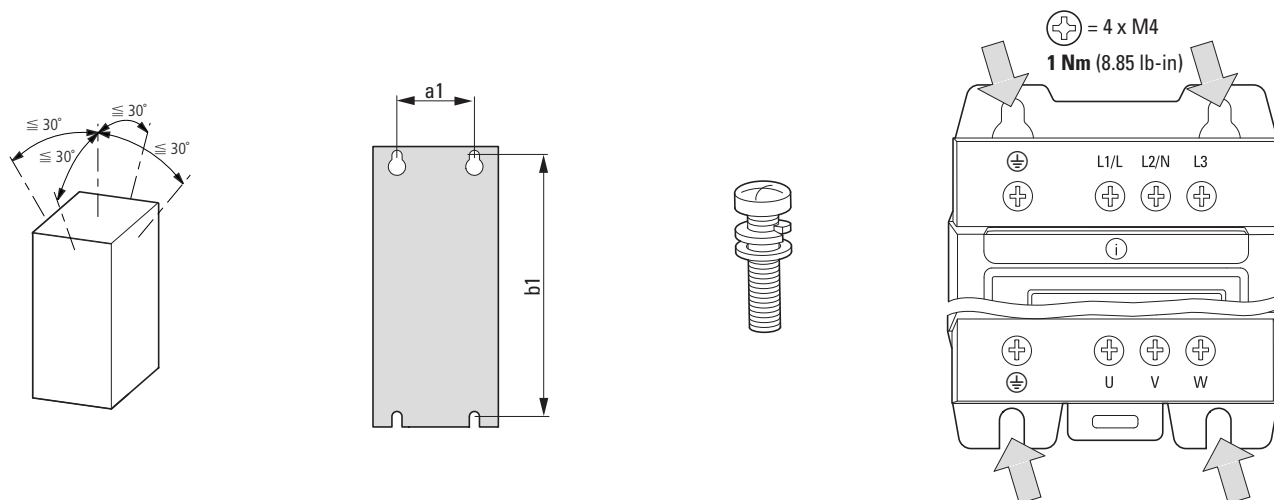

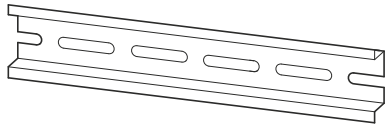

IEC/EN 60715

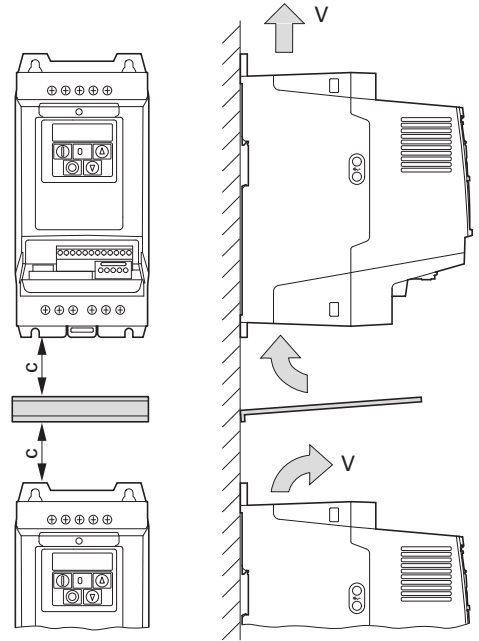
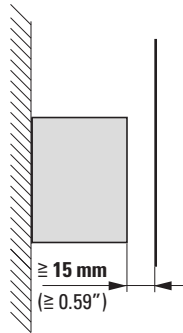
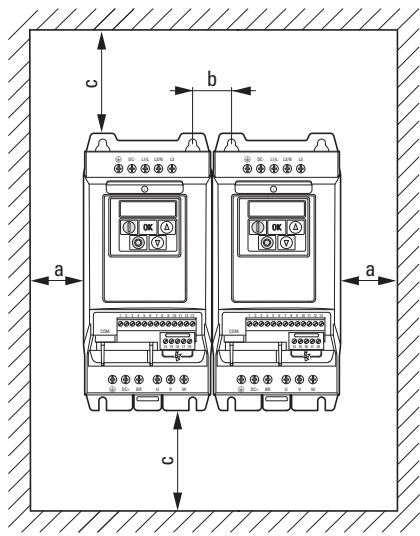
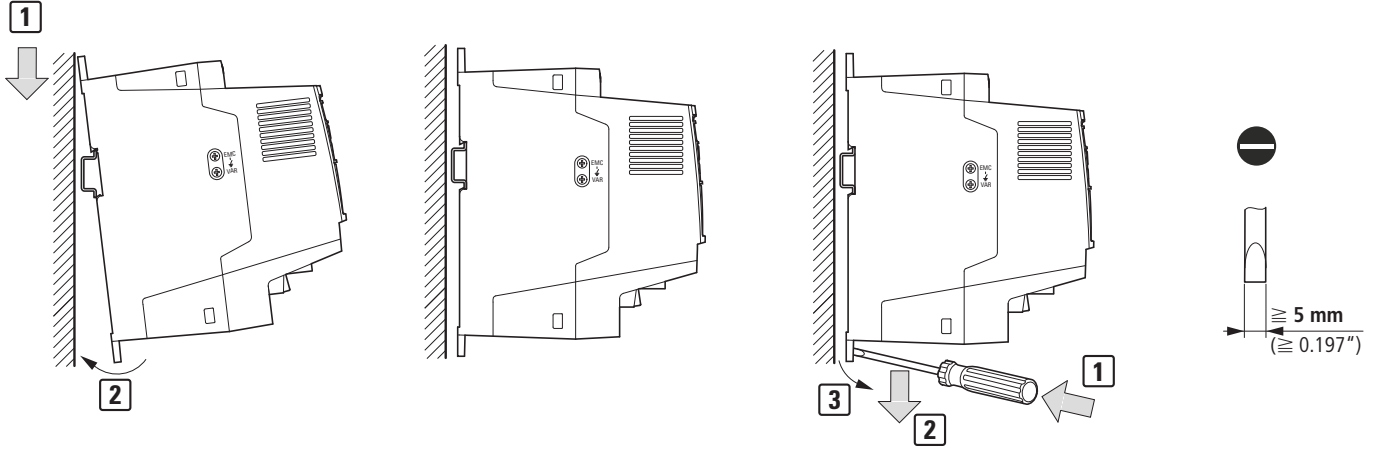
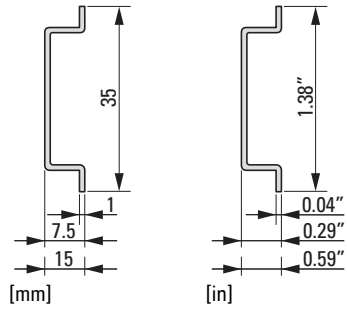

	<b>a</b> mm (in)	<b>b</b> mm (in)	<b>c</b> mm (in)	<b>V</b> m <sup>3</sup> /h (cfm)
FS2	50 (1.97)	32 (1.26)	75 (2.95)	18.69 (11)
FS3	50 (1.97)	31 (1.22)	100 (3.94)	44.17 (26)

10/13 IL04020010Z

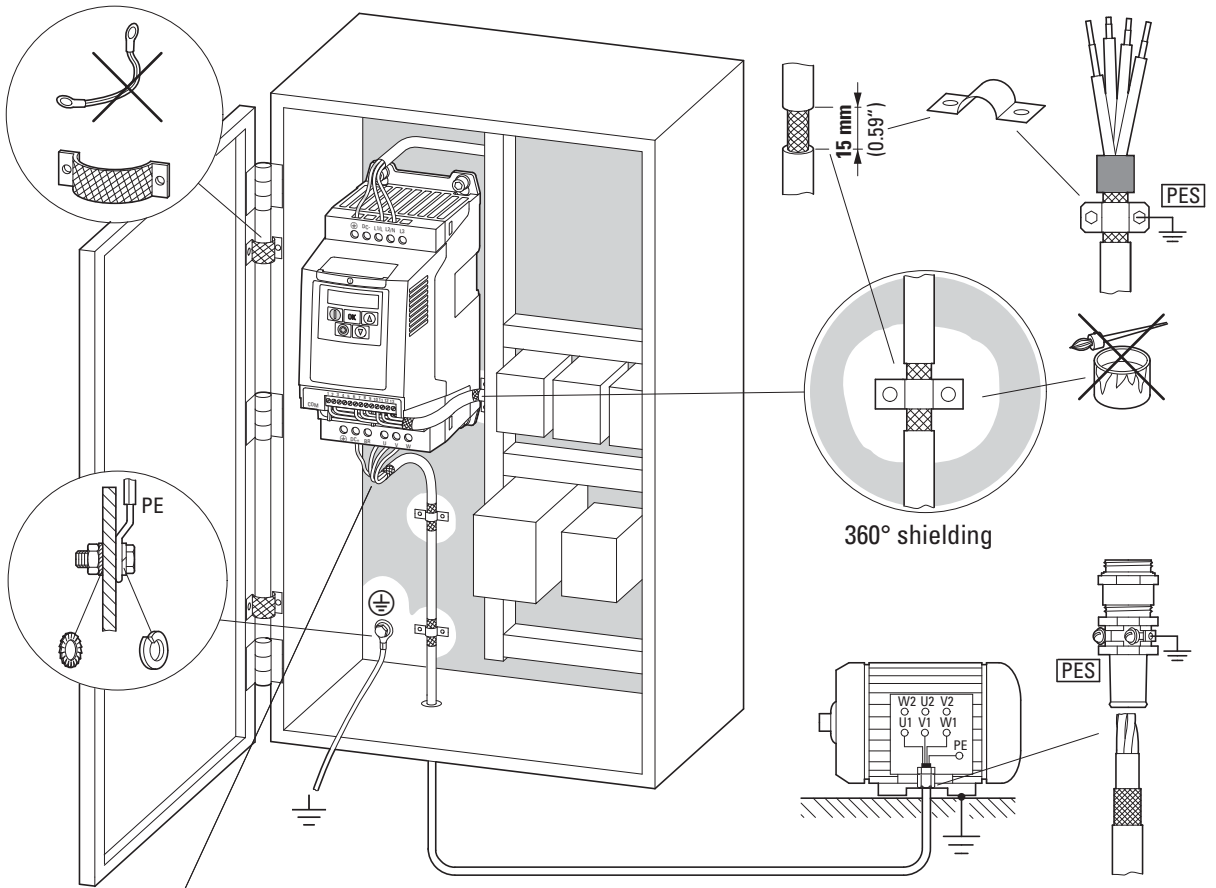

10/13 IL04020010Z

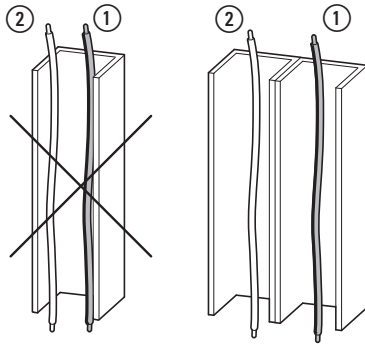
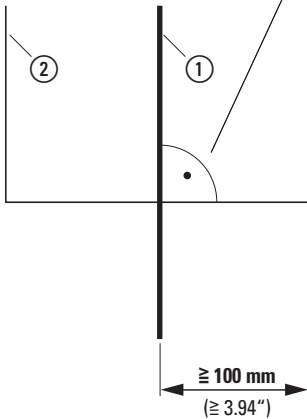

- ① Power: L1, L2, L3, N, PE, U, V, W, DC+, DC-, RB
- ② Control: 1, 2, ... 18, Modbus, CANopen

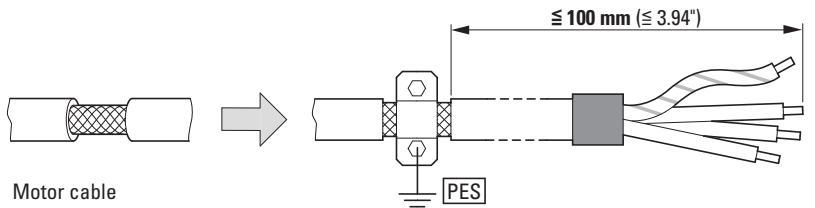

- en Option – de Option – fr Option – es Opción – it Opzione – zh 选项 –
- ru Опция – nl Optie – da Option – el Προαιρετικός εξοπλισμός –
- pt Option – sv Lisävaruste – cs Volitelně – et Lisavarustus –
- hu Opció – lv Orcija – lt Pasirinktis – pl Opcja – sl Opcija –
- sk Voľba – bg опция – ro Opțiunea – hr Opcija

**DX-EMC-MNT-...**

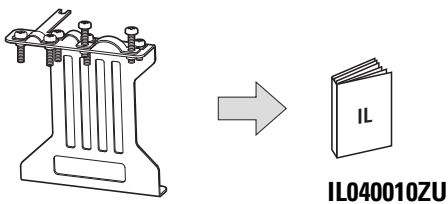

**EMC Filter OFF**

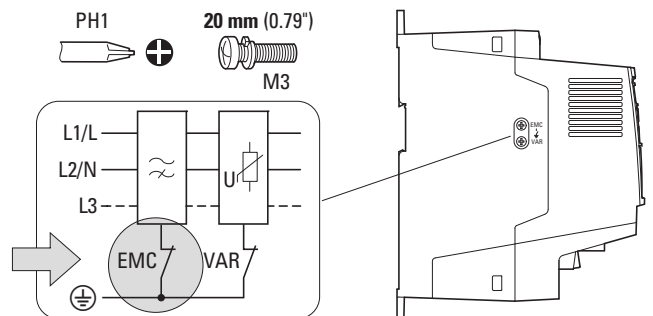

**(en) NOTICE**  
Connect only in voltage-free state!

**(de) ACHTUNG**  
Nur im spannungsfreien Zustand anschließen!

**(fr) ATTENTION**  
Raccordez l'appareil uniquement hors tension !

**(es) CUIDADO**  
¡Conectar únicamente en estado sin tensión!

**(it) AVVISIO**  
Collegare solo in assenza di tensione!

**(zh) 注意**  
必須在斷電狀態下進行連接！

**(ru) ВНИМАНИЕ**  
Подключать только в обесточенном состоянии!

**(nl) OPGELET**  
Alleen in spanningsloze toestand aansluiten!

**(da) VIGTIGT**  
Må kun tilsluttes i spændingsfri tilstand!

**(el) ΕΠΑΓΓΡΥΠΝΗΣΗ**  
Συνδέστε μόνο όταν δεν επικρατεί τάση!

**(pt) ADVERTÊNCIA**  
Ligar apenas com a tensão desligada!

**(sv) OBSERVERA**  
Får endast anslutas i späningsfritt tillstånd!

**(fi) ILMOITUS**  
Kytke vain jännitteettömässä tilassa!

**(cs) UPOZORNĚNÍ**  
Připojujte jen při zcela odpojeném napájení!

**(et) TÄHELEPANU**  
Ühendada ainult pingevabas olekus!

**(hu) FIGYELEM**  
Csak feszültségmentes állapotban csatlakoztassa!

**(lv) UZMANĪBU**  
Pieslēgt tikai tad, kad nenotiek sprieguma padeve!

**(lt) DĖMESIO**  
Prijungti tik tada, kai išjungta įtampa!

**(pl) UWAGA**  
Podłączac zawsze po uprzednim odłączeniu od zasilania elektrycznego!

**(sl) POZOR**  
Napravo priključite le, ko ni pod napetostjo!

**(sk) UPOZORNENIE**  
Napájat' len v stave bez napätia!

**(bg) ПРЕДУПРЕЖДЕНИЕ**  
Свързвайте само, когато уреда не е под напрежение!

**(ro) ATENTJE**  
Conectați doar când aparatul nu se află sub tensiune!

**(hr) POZOR**  
Priključujte samo u beznaponskom stanju!

**FS2, FS3: A1 = 10 mm (0.39")**

**Mains 1 ~**

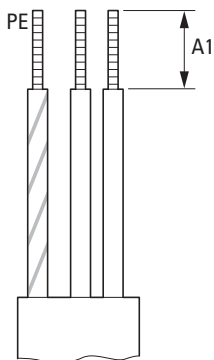

**Mains 3 ~**

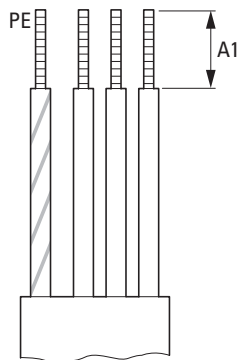

**Motor**

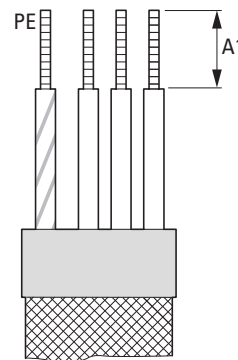

**Brake Resistor**

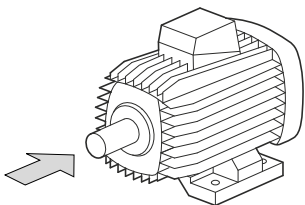
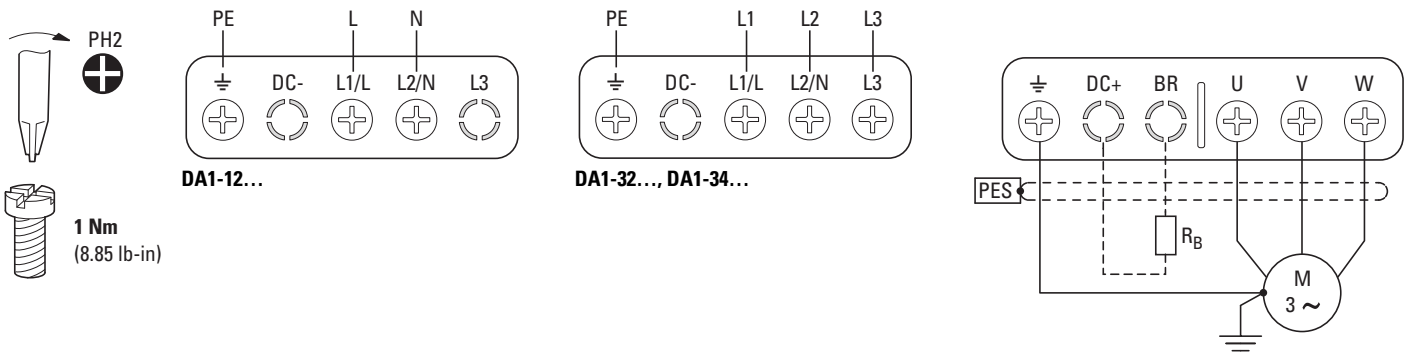
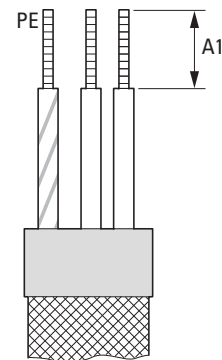

DA1	Motor
U	U1
V	V1
W	W1

230/400 V	3.2/1.9 A
0,75 KW	cosφ 0.79
1410 mi n <sup>-1</sup>	50 Hz

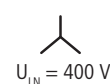
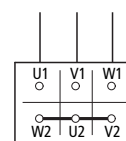
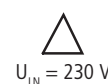
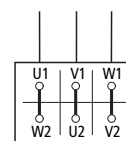
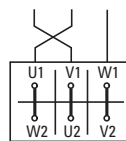
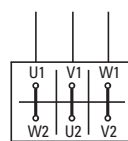

**Mains**

1 ~ 200 V - 240 V ±10 %, 50/60 Hz (DA1-12...)

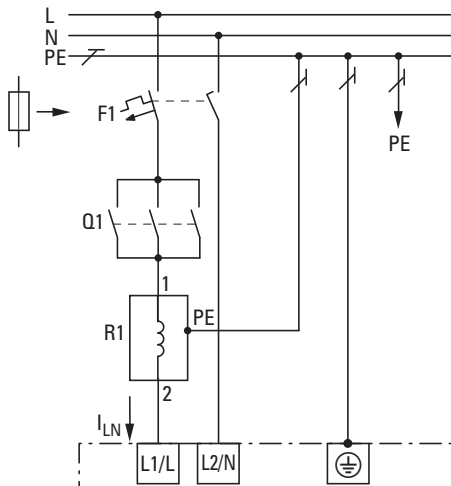

**Mains**

3 ~ 200 V - 240 V ±10 %, 50/60 Hz (DA1-32...)  
3 ~ 380 V - 480 V ±10 %, 50/60 Hz (DA1-43...)

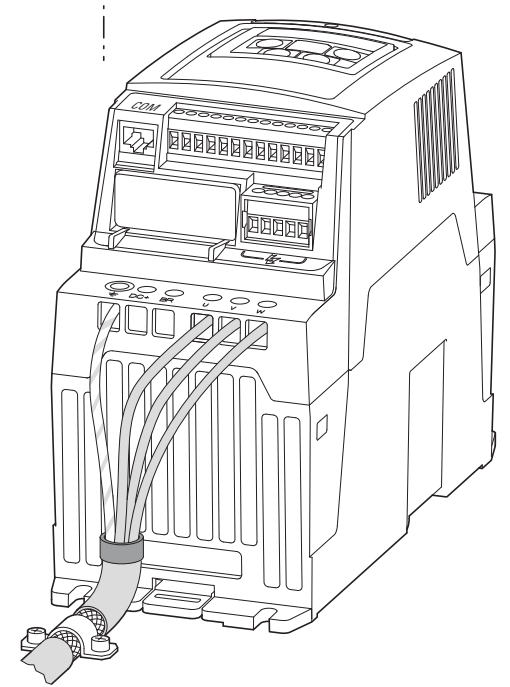
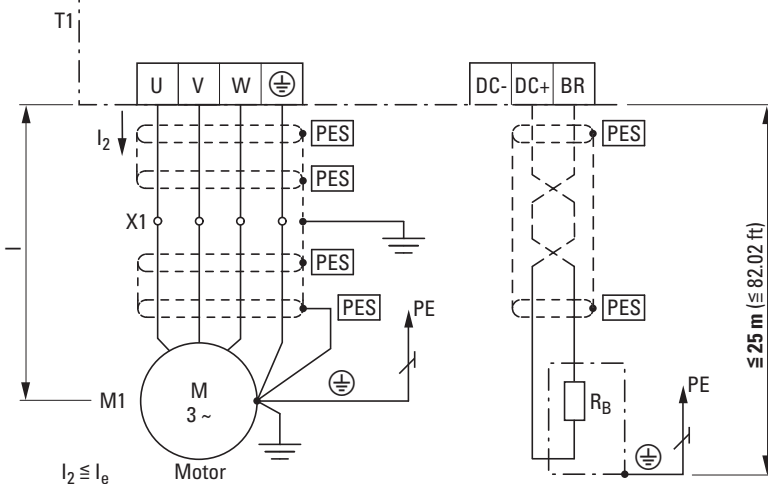
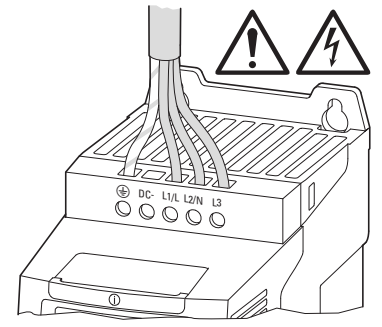
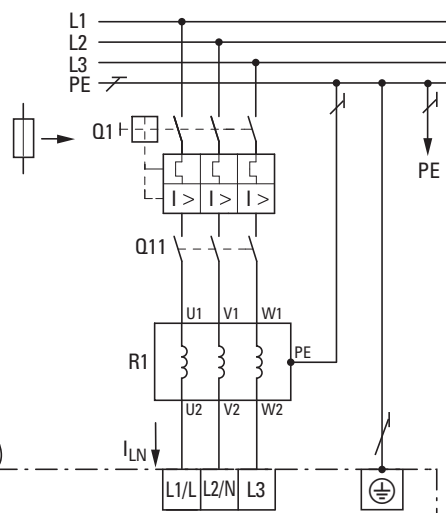

10/13 IL04020010Z

EMC	I	I	DA1
C1	≤ 1 m	≤ 3.28 ft	DA1-12...
C2	≤ 5 m	≤ 16.4 ft	DA1-12..., DA1-32..., DA1-34...
C3	≤ 25 m	≤ 82.02 ft	DA1-12..., DA1-32..., DA1-34...

	Frame Size	$I_{LN}$	F1/Q1 MCB (type B)	Mains		$I_e$	Motor		P		R <sub>B</sub>		
		A	A	mm <sup>2</sup>	AWG	A	mm <sup>2</sup>	AWG	kW	HP	Ω	mm <sup>2</sup>	AWG
DA1-124D3...	FS2	8.5	16 (15)	2 x 2.5	2 x 12	4.3	3 x 1.5	3 x 14	0.75	1	100	1.5	14
DA1-127D0...	FS2	13.9	20	2 x 4	2 x 10	7	3 x 1.5	3 x 14	1.5	2	50	1.5	14
DA1-12011...	FS2	19.5	25	2 x 10	2 x 8	10.5	3 x 1.5	3 x 14	2.2	3	35	1.5	14
DA1-324D3...	FS2	4.5	10	3 x 1.5	3 x 14	4.3	3 x 1.5	3 x 14	0.75	1	100	1.5	14
DA1-327D0...	FS2	7.3	10	3 x 2.5	3 x 14	7	3 x 1.5	3 x 14	1.5	2	50	1.5	14
DA1-32011...	FS2	11	16 (15)	3 x 4	3 x 12	10.5	3 x 1.5	3 x 14	2.2	3	35	1.5	14
DA1-32018...	FS3	18.8	20	3 x 4	3 x 10	18	3 x 2.5	3 x 10	4	5	20	2.5	10
DA1-32024...	FS3	24.8	32 (30)	3 x 10	3 x 8	24	3 x 4	3 x 10	5.5	7.5	20	4	10
DA1-342D2...	FS2	2.4	10 (6)	3 x 1.5	3 x 14	2.2	3 x 1.5	3 x 14	0.75	1	400	1.5	14
DA1-344D1...	FS2	4.3	10 (6)	3 x 1.5	3 x 14	4.1	3 x 1.5	3 x 14	1.5	2	200	1.5	14
DA1-345D8...	FS2	6.1	10 (6)	3 x 1.5	3 x 14	5.8	3 x 1.5	3 x 14	2.2	3	150	1.5	14
DA1-349D5...	FS3	9.8	16 (15)	3 x 2.5	3 x 12	9.5	3 x 1.5	3 x 14	4	5	100	1.5	14
DA1-34014...	FS3	14.6	20	3 x 4	3 x 12	14	3 x 1.5	3 x 12	5.5	7.5	75	1.5	12
DA1-34018...	FS3	18.1	25	3 x 4	3 x 8	18	3 x 2.5	3 x 10	7.5	10	50	2.5	10
DA1-34024...	FS3	24.7	40 (35)	3 x 10	3 x 8	24	3 x 4	3 x 10	11	15	40	4	10

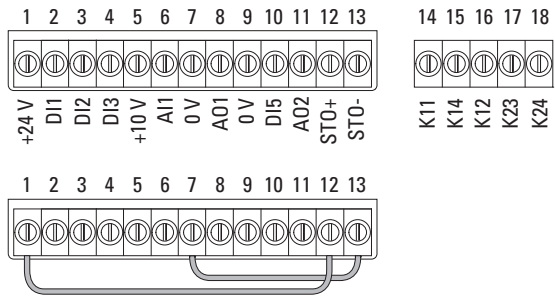
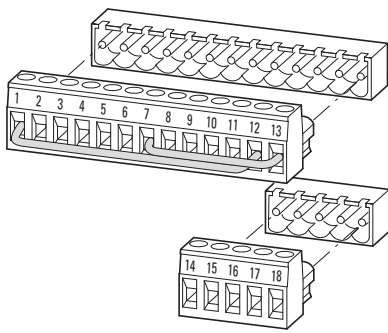

mm <sup>2</sup>	mm <sup>2</sup>	AWG	mm	in	M3	Nm	lb-in
0.14 - 2.5	0.14 - 2.5	30 - 12	6	0.24	0.8	7	0.4 x 2.5

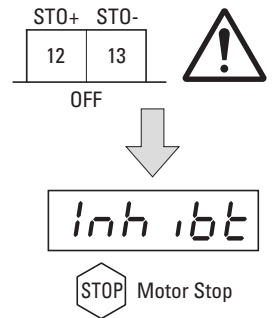
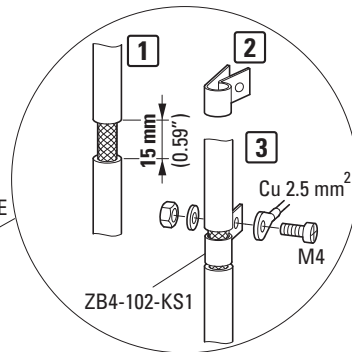
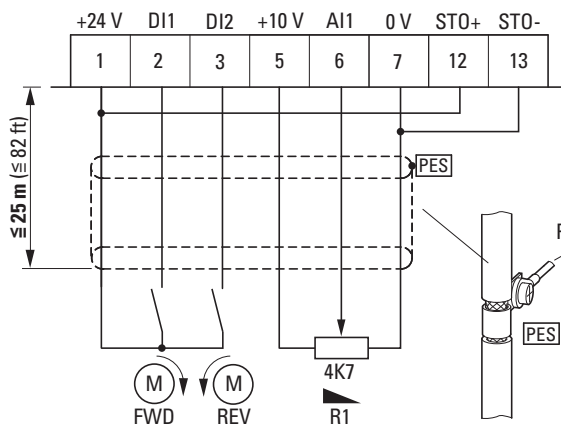
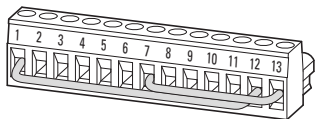
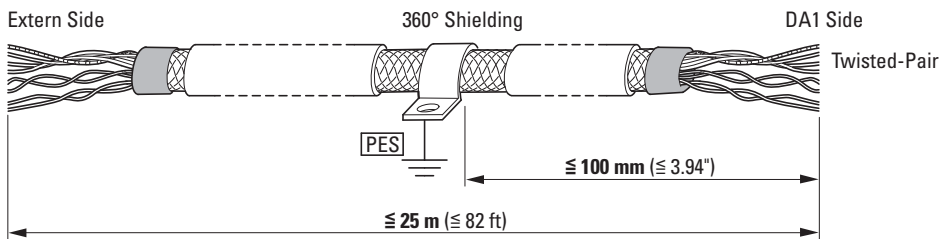

10/13 IL04020010Z

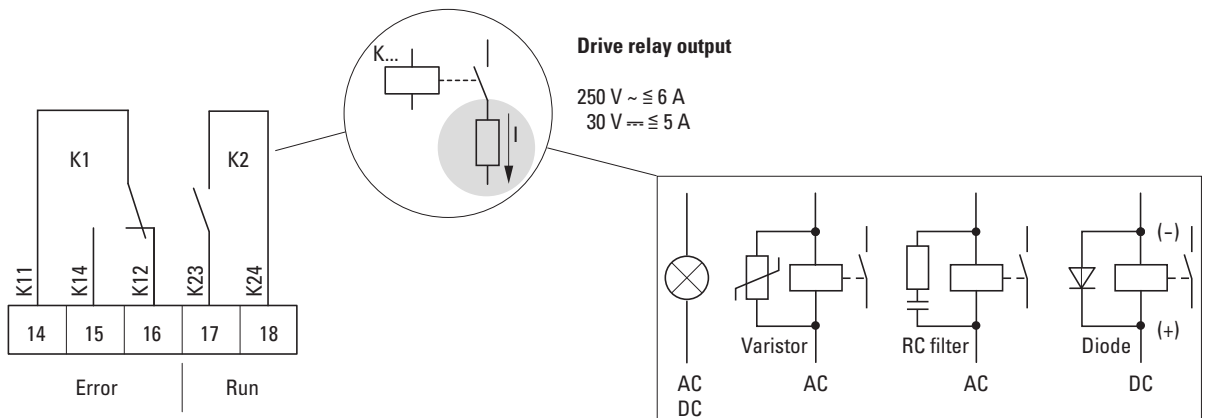
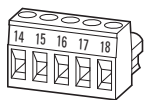

## STO (Safe Torque Off)

- (en) Shielded cable [PES] routed in an inherently short-circuit-proof and ground-fault-proof manner
- (de) Abgeschirmtes Kabel [PES] erd- und kurzschlussicher verlegen (eks)
- (fr) Câble blindé [PES] à poser avec protection contre courts-circuits/défauts à la terre
- (es) Tender el cable [PES] apantallado con seguridad de puesta a tierra y cortocircuito.
- (it) Posare il cavo [PES] schermato collegato a terra e protetto contro il cortocircuito
- (zh) 铺设接地防短路屏蔽电缆 [PES]
- (ru) Экранированный кабель [PES] прокладывается с защитой от замыкания на землю и коротких замыканий.
- (nl) Afgeschermde kabel [PES] geaard en kortsluitveilig installeren
- (da) Læg det afskærmede kabel [PES] jord- og kortslutningssikkert.
- (el) Τοποθετήστε το θωρακισμέν[ες] ο καλώδιο κατά τρόπον ώστε να είναι ασφαλές από βραχυκύκλωμα γείωσης και βραχυκύκλωμα.
- (pt) Dispor o cabo [PES] blindado com ligação à terra e protegido contra curto-circuito
- (sv) Dra den skärmede kabeln [PES] jordfels- och kortslutningssäkert.
- (fi) Sijoita suojattu kaapeli [PES] maa- ja oikosulkusuojatusti (mos).
- (cs) Stíněný kabel [PES] položte tak, aby byl bezpečný proti uzemnění a zkratu (buz).
- (et) Paigaldage varjestatud kaabel [PES] maandus- ja lühiskaitstult (mlk).
- (hu) Árnyékolt kábelt [PES] földelvé és rövidzármntesen kell lefektetni.
- (lv) Izvilkt ekranētu kabeli [PES], kas ir aizsargāts pret zemesslēgumiem un īsslēgumiem.
- (lt) Ekranuotą kabelį [PES] nutieskite apsaugotą nuo žemėjimo ir trumpojo jungimo.
- (pl) Kabel ekranowany [PES] ułożyć z zabezpieczeniem przed zwarciem i zwarciem doziemnym.
- (sl) Izoliran kabel [PES] speljite zavarovano pred zemeljskim in kratkim stikom.
- (sk) Uložte tiený kábel [PES], odolný voči skratu a náhodnému uzemneniu.
- (bg) Положете екраниран кабел [PES] и го заземете срещу късо съединение.
- (ro) Pozați cablul [PES] ecranat astfel încât să fie asigurată protecția la scurtcircuit și scurgeri la pământ.
- (hr) Zakrileni kabel [PES] postavite tako da bude zaštićen od uzemljenja i kratkog spoja.

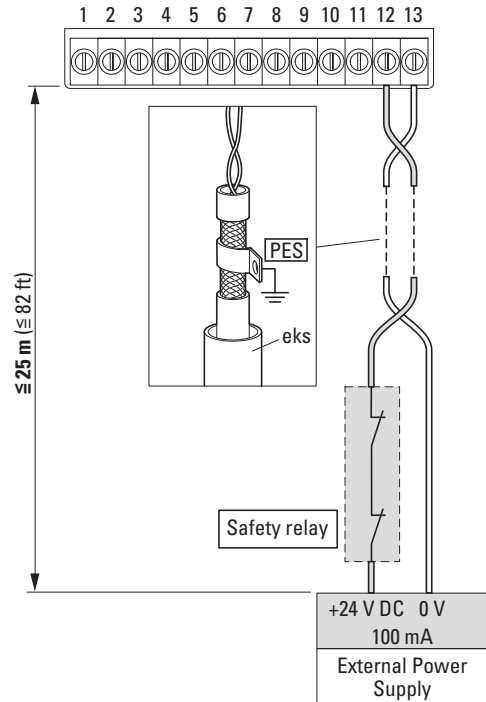
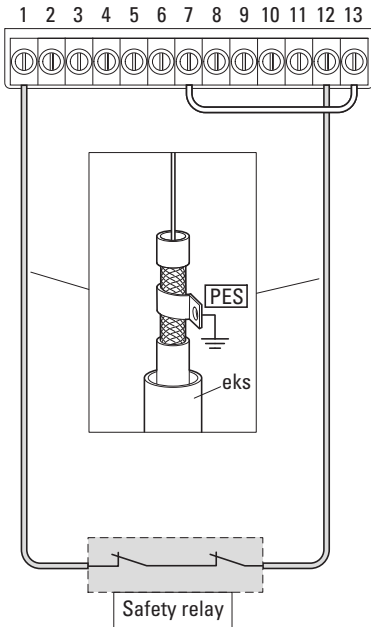

10/13 IL04020010Z

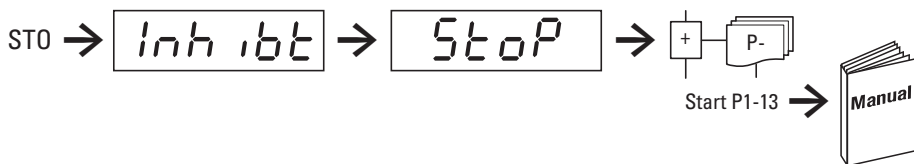

(en) Thermistor	(ru) Термистор	(fi) Termistori	(pl) Termistor
(de) Thermistor	(nl) Thermistor	(cs) Termistor	(sl) Termistor
(fr) Thermistance	(da) Thermistor	(et) Termistor	(sk) Termistor
(es) Termistor	(el) Θερμίστορ	(hu) Termisztor	(bg) Термистор
(it) Termistore	(pt) Thermistance	(lv) Termistors	(ro) Termistor
(zh) 热敏电阻	(sv) Termistor	(lt) Termistorius	(hr) Termistor

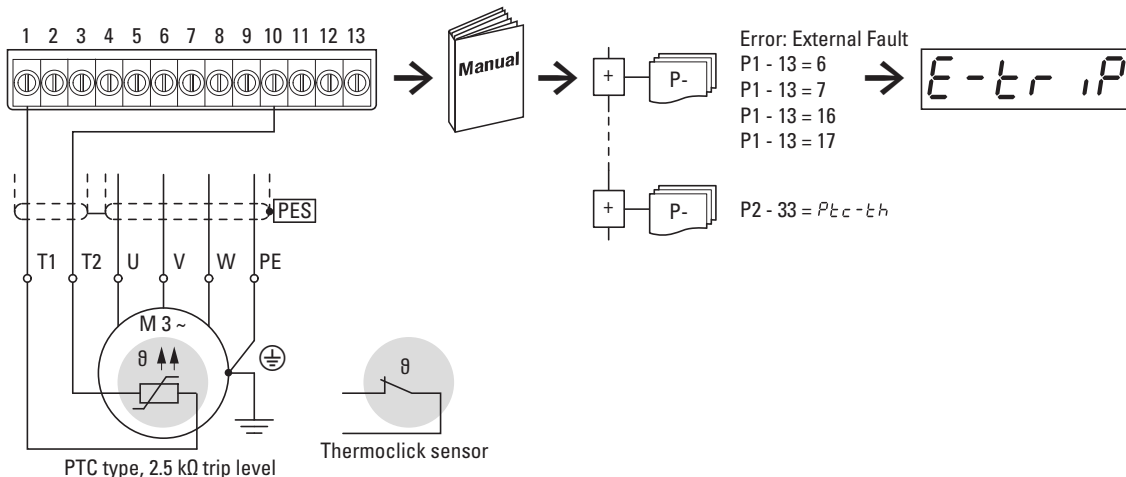

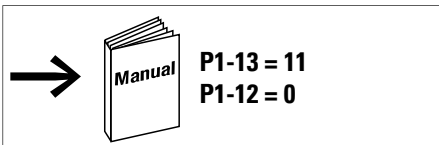

Input	L: 0 - 4 V DC	H: 8 - 30 V DC	Output
External Supply +24 V DC (100 mA)			<b>1</b> +24 V DC, < 100 mA
Digital Input 1 (DI1)	Stop	Enable, Run Forward Rotation	<b>2</b>
Digital Input 2 (DI2)	Stop	Enable, Run Reverse Rotation	<b>3</b>
Digital Input 3 (DI3)	AI1	FF1/FF2	<b>4</b>
Analog Input 1 (AI1): 0 - 10 V DC, < 20 mA, Frequency Setpoint value [Digital Input 4 (DI4)] → P1-13			<b>5</b> +10 V DC, < 10 mA
0 V			<b>6</b>
0 V			<b>7</b> 0 V
Digital Input 5 (DI5) [Analog Input 2 (AI2)] → P1-13	FF1, Fixed Frequency (P2-01 = 5 Hz)	FF2, Fixed Frequency (P2-02 = 10 Hz)	<b>8</b> Analog Output 1 (AO1): 0 - 10 V DC, < 20 mA, Output Frequency [Digital Output 1 (DO1)] → P2-11, P2-12
			<b>9</b> 0 V
			<b>10</b>
Safe Torque Off	Stop	STO+ (18 - 30 V DC)	<b>11</b> Analog Output 2 (AO2): 0 - 10 V DC, < 20 mA, Output Current [Digital Output 2 (DO2)] → P2-13, P2-14
Safe Torque Off	Stop	STO- (0 V)	<b>12</b>
			<b>13</b>
			<b>14</b> Relay (K11 = COM)
			<b>15</b> Relay (K14 = NO), Healthy
			<b>16</b> Relay (K12 = NC), Error
			<b>17</b> Relay (K23 = COM)
			<b>18</b> Relay (K24 = NO), RUN

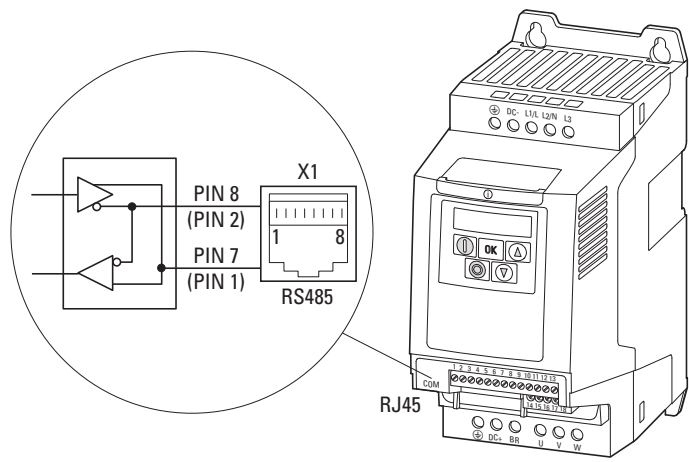
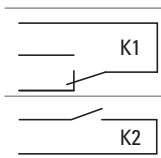

PIN 1	CANopen -
PIN 2	CANopen +
PIN 3	0V
PIN 4	OP-Bus -
PIN 5	OP-Bus +
PIN 6	+ 24 V
PIN 7	Modbus RTU -
PIN 8	Modbus RTU +

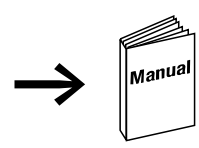

10/13 IL04020010Z

DA1-12...

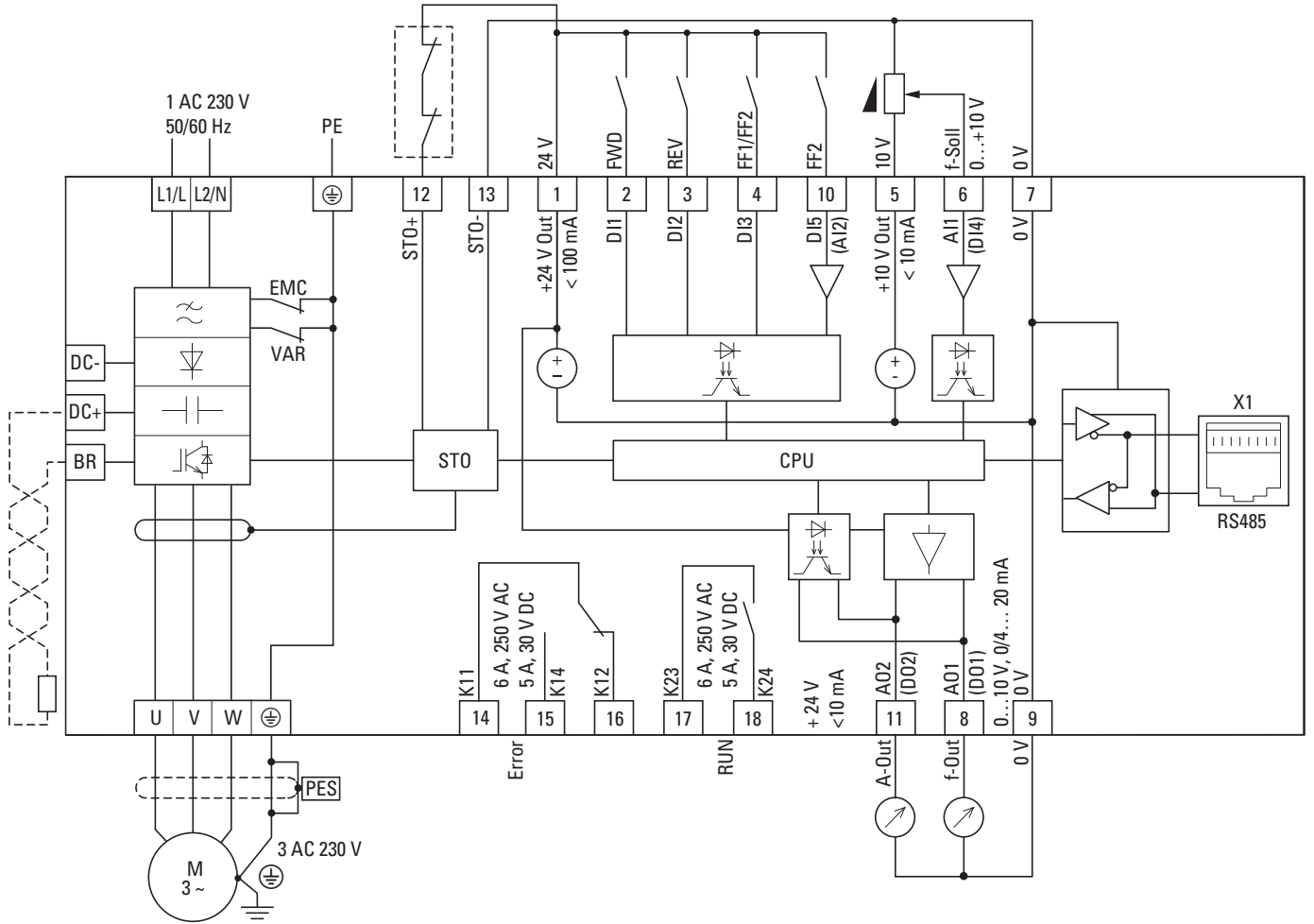

10/13 IL04020010Z

DA1-32...  
DA1-34...

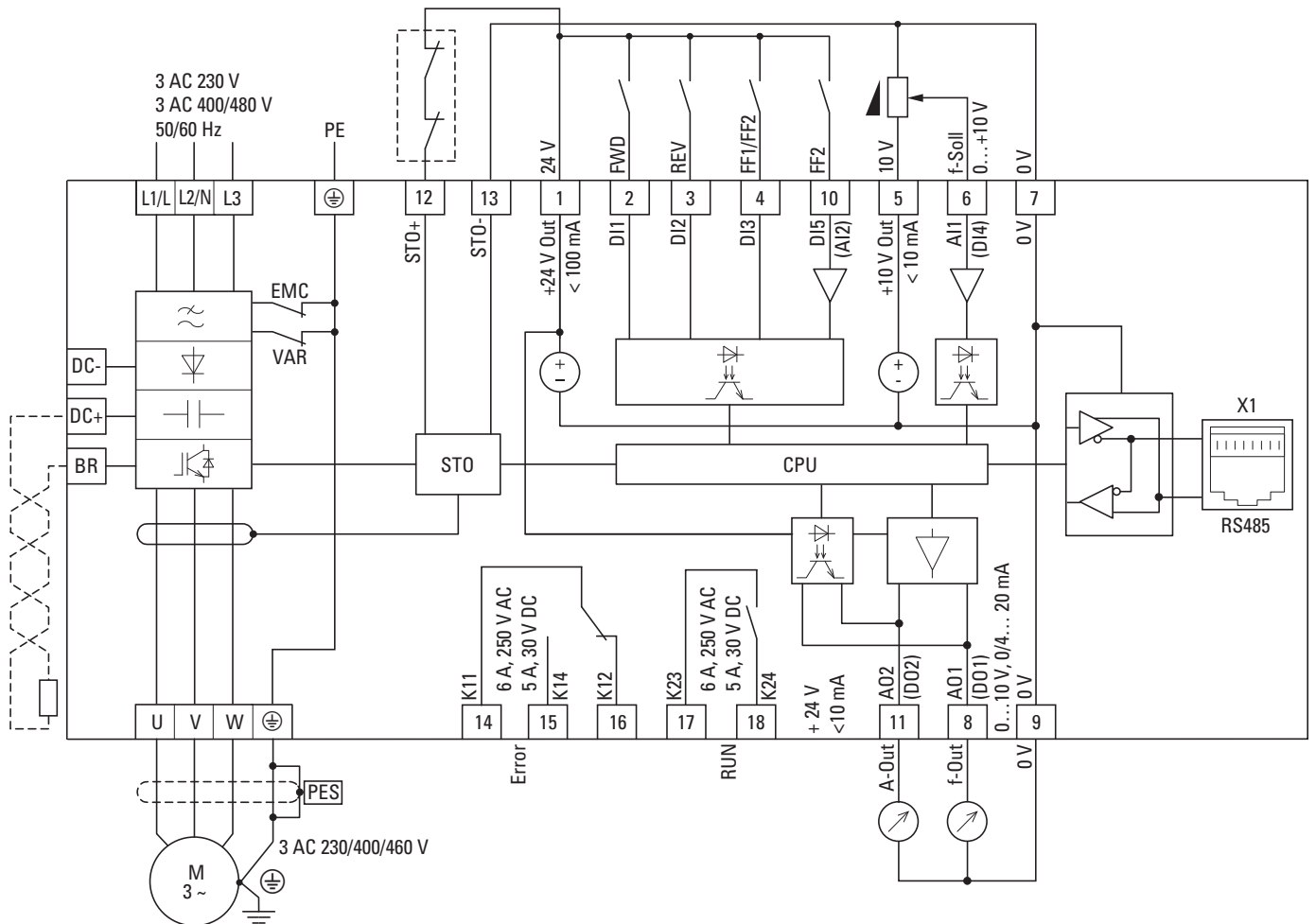

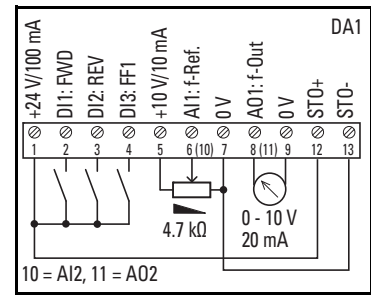
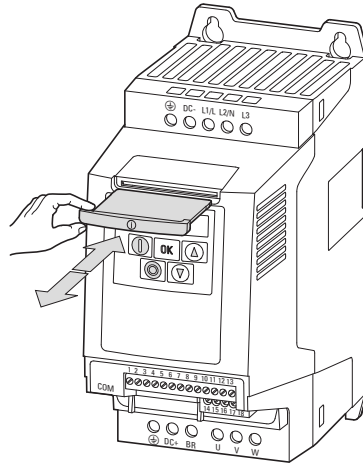
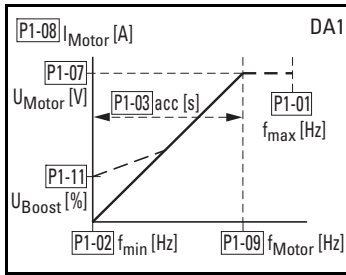

**Motor protection**

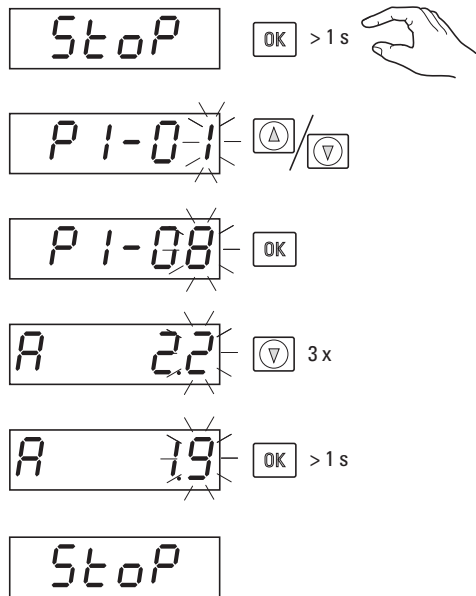
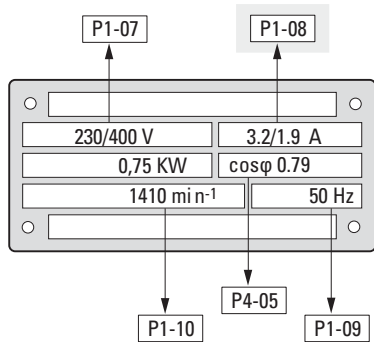

**Hand modus (Keypad)**

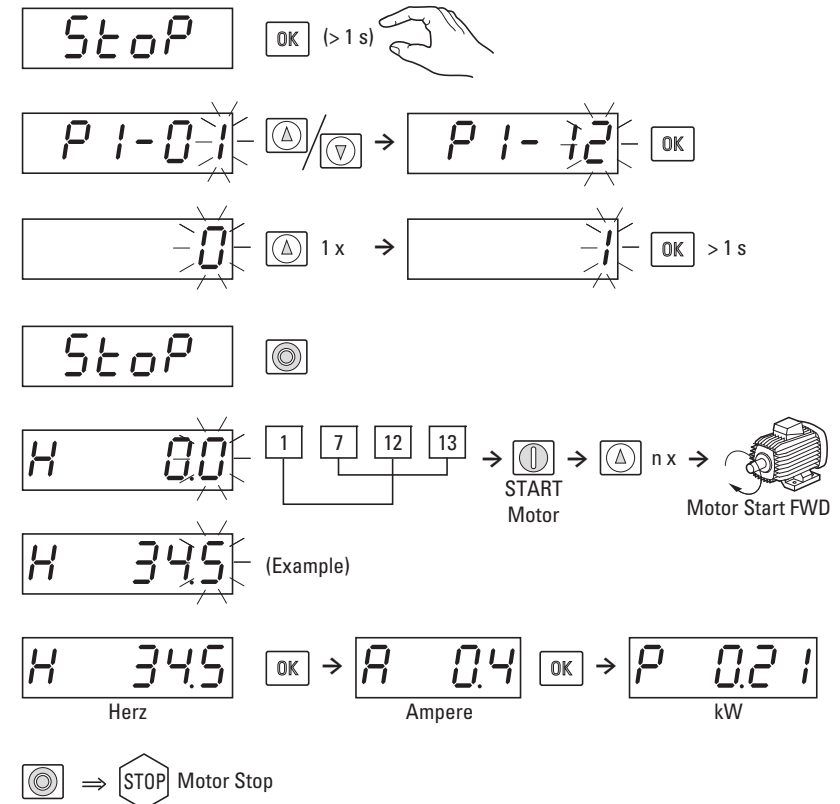
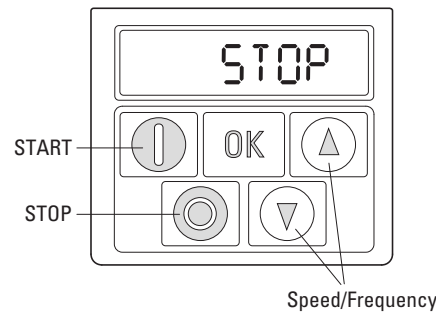

10/13 IL04020010Z

**(en) CAUTION**

In the territory of the EU Directive the frequency-controlled devices and their accessories must be taken into operation only when the machine has been determined to fulfil the protection requirements of Machinery Safety Directive 89/392/EEC.

Ensure EMC-compliant installation. Lay control and communication cables spatially separated from the motor cable. Ensure a large contact area connection between **[PES]** cable screen and PE.

**(de) VORSICHT**

Im Geltungsbereich der EG-Richtlinien dürfen die frequenzgesteuerten Geräte und deren Zubehör nur dann in Betrieb genommen werden, wenn festgestellt wird, dass die Maschine die Schutzanforderungen der Maschinenrichtlinie 89/392/EWG erfüllt.

EMV-gerechter Aufbau. Steuer- und Netzleitungen räumlich getrennt von der Motorleitung verlegen. **[PES]** Leitungsschirm großflächig mit PE verbinden.

**(fr) AVERTISSEMENT**

En application des directives européennes, les convertisseurs de fréquence et leurs accessoires ne doivent être mis en service que s'il a été vérifié que la machine répond aux exigences de la directive machines 89/392/CEE.

Montage conforme aux règles de la CEM. Eloigner les câbles de commande et de réseau des câbles puissance. Relier le blindage au PE en assurant de grandes surfaces de contact.

**(es) ATENCIÓN**

En el campo de aplicación de la normativa CE, los dispositivos controlados por frecuencia y sus correspondientes accesorios sólo deberán ponerse en marcha cuando se asegure que la máquina cumple con las exigencias de seguridad de la normativa de máquinas 89/392/CEE.

El montaje debe cumplir CEM. Los cables de mando y de conexión a red se deben instalar independientemente del cable de conexión al motor. El cable apantallado **[PES]** se debe conectar a masa utilizando una amplia superficie de contacto.

**(it) ATTENZIONE**

Nel campo di validità delle direttive CE, gli apparecchi a controllo di frequenza e i loro accessori possono essere messi in esercizio soltanto se si verifica che la macchina soddisfa i requisiti di sicurezza della direttiva macchine 89/392/CEE

Montaggio secondo CEM. Disporre i cavi comandi e di alimentazione separati dal cavo del motore. Collegare lo schermo del cavo **[PES]** con PE con un'ampia superficie.

**(zh) 小心**

根据欧盟设备一致性规范，安装频率控制设备及其配件时，应确保设备满足机器规范 89/392/EWG 中关于设备保护的要求。

**[PES]** 按照电磁兼容规范正确安装。应将控制电缆和电源电缆与机电电缆分开。大面积采用 PE 包裹电缆。

**(ru) ОСТОРОЖНО**

В сфере действия директив ЕС устройства с частотным управлением и их оснащение должны вводиться в эксплуатацию только в том случае, если установлено, что данное оборудование соответствует требованиям по защите Директивы о машинном оборудовании 89/392/EWG.

Сборка соответственно электромагнитной совместимости. Линии управления и электросети прокладывать в пространственном отношении отдельно от линии двигателя. **[PES]** силовой экран соединять с PE по большой площади.

**(nl) VOORZICHTIG**

Binnen het geldigheidsgebied van de EC-richtlijnen mogen de frequentieregelden apparaten en de toebehoren daarvan alleen in bedrijf worden genomen, wanneer wordt vastgesteld, dat de machine aan de veiligheidsvoorschriften van de machinerichtlijn 89/392/EWG voldoet.

EMC-conforme constructie. Besturings- en netkabels ruimtelijk gescheiden van de motorkabel leggen. **[PES]** Kabelafscherming over groot oppervlak met PE verbinden.

**(da) FORSIGTIG**

I det område, hvor EF-direktiverne er gældende, må det frekvensstyrte udstyr og dets tilbehør kun tages i anvendelse, hvis det konstateres, at maskinen opfylder beskyttelseskravene i maskindirektivet 89/392/EGF.

EMC-korrekt installation. Træk styre- og netledninger rumligt adskilt fra motorledningen. **[PES]** Sørg for en stor kontaktfldade mellem PES ledningsafskærmning og PE.

**(el) ΠΡΟΣΟΧΗ**

Στο πεδίο εφαρμογής των οδηγιών της ΕΚ, οι ηλεκτρονικές μέσω συχνότητας συσκευές και τα παρελκόμενά τους επιτρέπεται να τίθενται σε λειτουργία μόνο εφόσον διαπιστωθεί ότι το μηχάνημα πληροί τις απαιτήσεις προστασίας της οδηγίας της ΕΚ για τα μηχανήματα 89/392/ΕΟΚ.

Κατασκευή σύμφωνα με τις απαιτήσεις ΗΜΣ. Εγκαθιστάτε τους αγωγούς ελέγχου και δικτύου ανεξάρτητα από τον αγωγό του κινητήρα. **[PES]** Συνδέετε τη θωράκιση των αγωγών σε μεγάλη επιφάνεια με τη γείωση.

**(pt) CUIDADO**

No âmbito das directivas da CE, os aparelhos comandados por frequência e os respectivos acessórios só podem ser postos em operação se for comprovado que a máquina atende às exigências de protecção da directiva de máquinas 89/392/CE.

Estrutura com compatibilidade electromagnética. Dispon os fios de comando e de rede separados do fio do motor. **[PES]** Ligar uma área grande da blindagem do cabo (PES) com o PE.

**(sv) FÖRSIKTIG**

I giltighetsområdet för EG-direktiven får de frekvensstyrda apparaterna och deras tillbehör endast tagas i drift när man fastställt att maskinen uppfyller skyddskraven i maskindirektiv 89/392/EEC.

EMC-anpassad uppbyggnad. Styr- och nätledningar dras avskilda från motorledningarna. **[PES]** Förbind ledningsskärm över ett brett område med PE.

**(fi) HUOMIO**

EU-direktiivien voimassaoloalueella taajuusohjatut laitteet ja niiden varusteet saa ottaa käyttöön vain silloin, kun todetaan, että kone täyttää konedirektiivin 89/392/ETY suojausvaatimukset.

EMC-mukainen rakenne. Ohjaus- ja verkkojohdot on asennettava tilalotteisesti erotettuina. Johdonsuoja on liitettävä laajasti maadoitukseen **[PES]**.

**(cs) POZOR**

V rozsahu platnosti směrnici ES smí být frekvenčně řízené přístroje a jejich příslušenství uvedeny do provozu jedině tehdy, pokud je zjištěno, že stroj splňuje požadavky ochrany stanovené směrnici 89/392/EHS o strojních zařízeních.

Nástavba odpovídající směrnici EMC. Řídící a síťová vedení pokládejte prostorově oddělená od vedení motoru. **[PES]** Stínění vedení spojte velkoplošně s PE.

**(et) ETTEVAATUST**

EÜ-direktiivi kehtivuspiirkonnas võib sagedusjuhitavaid seadmeid ja nende lisaseadmeid kasutusele võtta ainult siis, kui on kindlaks tehtud, et masin vastab masinadirektiivi 89/392/EMÜ kaitse nõuetele.

Elektromagnetilisele ühilduvusele vastav ehitus. Juhtimis- ja võrgukaablid paigaldada mootori toitekaablist ruumiliselt eraldatuna. **[PES]** Kaabli kaitsekraan ühendada ulatuslikult talitlusmaandusega.

**(hu) VIGYÁZAT**

Az EK irányelvek hatályosságai területén a frekvenciavezérelt készülékeket és azok tartozékait csak akkor szabad üzembe helyezni, ha megállapítást nyert, hogy a gép megfelel a gépek biztonságáról szóló, 89/392/EGK számú irányelv biztonsági követelményeinek.

Elektromágnesesen összeférhető kivétel biztositson. A motorvezetékek től térben elkülönítve vezesse vezérlő és hálózati vezetékeket. **[PES]** Nagy felületen csatlakoztassa a védőföldeléshez a vezetékmegkötést.

**(lv) IEVĒROT PIESARDZĪBU**

Valstīs, kurās ir spēkā EK direktīvas, ierīču ar frekvenčvadību un to piederumu ekspluatāciju drīkst sākt tikai tad, ja ir konstatēta iekārtas atbilstība Mašīnu direktīvai 89/392/EEK ietvertajām aizsardzības prasībām.

EMS atbilstoša uzbūve. Vadības un tīkla kabelus izvietot atsevišķi no motora kabeļa. **[PES]** Vada ekrānu plašā virsmā savienot ar PE.

**(lt) ATSARGIAI**

EB direktyvų taikymo srityje dažniniu būdu valdomos įrenginius ir jų priedus leidžiama pradėti naudoti tik tada, kai nustatoma, kad įrenginys atitinka Mašinų direktyvos 89/392/EEB keliamus apsaugos reikalavimus.

Montažas turi atitikti EMS reikalavimus. Valdymo ir duomenų tinklo kabelius išdėstyti atokiai nuo variklio kabelio. **[PES]** Kabelio ekraną dideliu paviršiumi sujungti su žeminiu.

**(pl) OSTROŻNIE**

Na obszarze obowiązywania dyrektyw WE urządzenia sterowane częstotliwościowo wolno wprowadzać do eksploatacji tylko wtedy, gdy zostanie stwierdzone, że maszyna spełnia wymagania ochronne dyrektywy maszynowej 89/392/EWG.

Konstrukcja zgodna z dyrektywą w sprawie kompatybilności elektromagnetycznej (EMC). Przewody sterowania i zasilania elektrycznego należy układać oddzielnie od przewodów silnika. **[PES]** Ekranowanie połączyć z przewodem uziemiającym na większej powierzchni.

**(sl) PREVIDNO**

Na območju veljavnosti direktiv ES je zagon frekvenčno krmiljenih naprav in njihovega pribora dovoljen le tedaj, ko je bilo ugotovljeno, da stroj ustreza varnostnim zahtevam Direktive o strojih 89/392/EGS.

Montaža v skladu z EMZ. Krmilne in omrežne vodnike napeljte ločeno od vodnikov motorja. **[PES]** Oklep vodnika na veliki površini povežite z zaščitnim vodnikom.

**(sk) VÝSTRAHA**

V krajinách, ktoré spadajú pod pôsobnosť smerníc ES smú byť rádiovio ovládané zariadenia a ich príslušenstvo uvedené do prevádzky len ak je zabezpečené, že stroj spĺňa ochranné ustanovenia smernice č. 89/392/EHS o strojových zariadeniach.

Montáž v súlade s požiadavkami elektromagnetickej kompatibility. Ovládacie a sieťové vedenia uložte v priestore oddelene od vedenia motoru. **[PES]** Zabezpečte veľkú kontaktnú plochu medzi káblovým tienением a PE.

**(bg) ВНИМАНИЕ**

В сферата на действие на изискванията на ЕС устройствата с честотно управление и техните допълнителни устройства могат да бъдат приведени в употреба, само ако се установи, че оборудването съответства на изискванията за безопасност на машинно оборудване спрямо 89/392/EWG.

Монтаж с електромагнитна съвместимост. Полагане на контролните и мрежови проводници пространствено отделно от проводника на двигателя. **[PES]** Осигурете по-голяма контактна площ между силовия екран и PE.

**(ro) PRECAUTIE**

În cadrul sferii de aplicare a directivei UE dispozitivele controlate prin frecvență și accesoriile acestora au voie să fie puse în funcțiune doar dacă se stabilește că aparatul îndeplinește cerințele Directivei 89/392/CEE privind mașinile.

Montajul trebuie să fie compatibil EMC. Poziționați cablurile de control și de rețea la distanță de cablul motorului. **[PES]** Asigurați o suprafață de contact mare între izolația cablului și PE.

**(hr) OPREZ**

U području valjanosti Direktiva EZ frekvencijski upravljani uređaji i njihov pribor smiju se puštati u rad samo ako se utvrdi da stroj ispunjava zahtjeve za zaštitom iz Direktive o strojevima 89/392/EEZ.

Konstrukcija u skladu s EMC-om. Upravljački i mrežni vodovi prostorno položeni odvojeno od voda motora. **[PES]** zaslon kabela povezan PE-om na velikoj površini.

**Wiring Warnings for Electrical Practices and Wire Sizes**

The Cautions, Warnings, and instructions in this section summarize the procedures necessary to ensure an inverter installation complies with Underwriters Laboratories® guidelines.

**NOTICE**  
Use 60/75 °C Cu wire only or equivalent.

**NOTICE**  
Open Type Equipment.

**NOTICE**  
Suitable for use on a circuit capable of delivering not more than 5,000 rms (AS) symmetrical amperes has:  
– 240 V maximum for DA1-12 and DA1-32 models  
– 480 V maximum for DA1-34 models

**Circuit Breaker and Fuse Sizes**

The variable frequency drives' connections to input power must include UL Listed inverse time circuit breakers with 600 V rating, or UL Listed fuses as shown in the table below.

**Terminal Tightening Torque and Wire Size**

The wire size range and tightening torque for field wiring terminals are presented in the table below.

**Wire Connectors**

**NOTICE**

Field wiring connections must be made by a UL Listed and CSA Certified ring lug terminal connector sized for the wire gauge being used. The connector must be fixed using the crimping tool specified by the connector manufacturer.

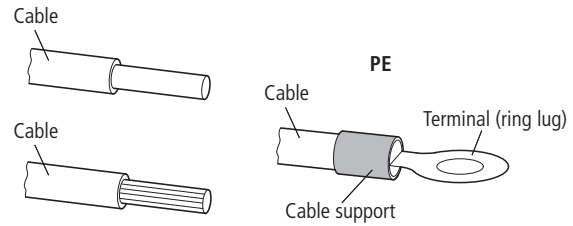

**Motor Overload Protection**

DA1 variable frequency drives provide solid-state motor overload protection, which depends on the proper setting of the following parameter: P1-08 "current limit".

Set the rated current [Amperes] of the motor(s) with the above parameters. The setting range is 25 % rated current to 100 % rated current, → manual MN04020005Z...

**NOTICE**

When two or more motors are connected to the inverter, they cannot be protected by the electronic overload protection. Install an external thermal relay on each motor.

Inverter Model	Mains Input Voltage	Fuse/Braker (UL-rated, class J, 600 V) A	Wiring Size range AWG	Motor Power		Wiring Size Range AWG	Screw Torque Power unit		
				kW	HP		lb-in	Nm	
DA1-124D3...	220-240 V Single Phase	15	12	0.75	1	14	9	1	
DA1-127D0...		20	10	1.5	2	14			
DA1-12011...		25	8	2.2	3	14			
DA1-324D3...	220-240 V Three Phase	6	14	0.75	1	14			
DA1-327D0...		10	14	1.5	2	14			
DA1-32011...		10	14	2.2	3	14			
DA1-32018...		25	10	4	5	10			
DA1-32024...		30	10	5.5	7.5	10			
DA1-342D2...		440-480 V Three Phase	6	14	0.75	1			14
DA1-344D1...			10	14	1.5	2			14
DA1-345D8...	10		14	2.2	3	14			
DA1-349D5...	15		14	4	5	14			
DA1-34014...	20		12	5.5	7.5	12			
DA1-34018...	25		10	7.5	10	10			
DA1-34024...		35	8	11	15	8			

1) kW @ 230 V/400 V, 50 Hz, 1500 min<sup>-1</sup>  
HP @ 230 V/460 V 60 Hz, 1800 rpm

→ AWG = American Wire Gauge. Smaller numbers represent increasing wire thickness.  
MCM/kcmil = 1,000 circular mils, a measure of wire cross-sectional area  
mm<sup>2</sup> = square millimeters, a measure of wire cross-sectional area

10/13 IL04020010Z