

Operation and Parts Manual

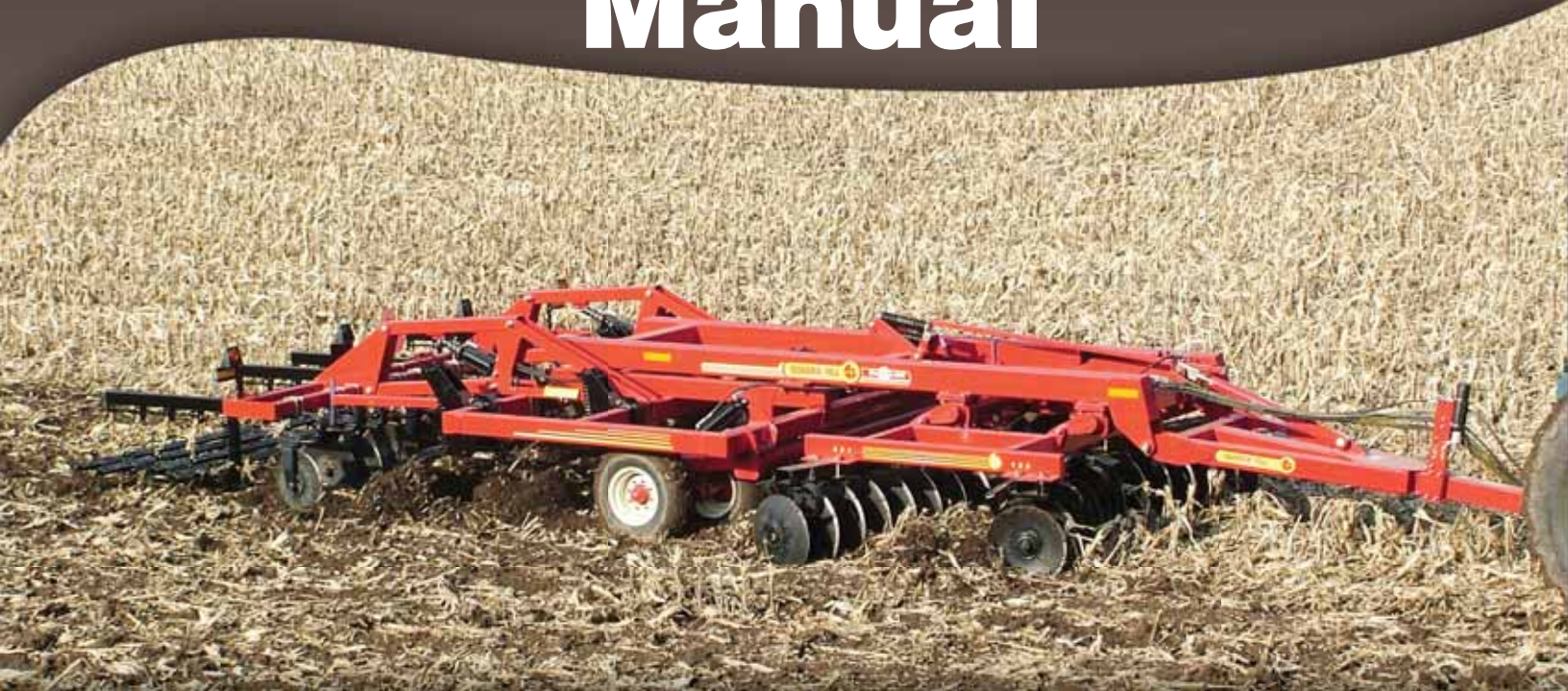

McFARLANE

QUADRA-TILL

200 Series

SIZES, SHATTERS, MIXES, & LEVELS



MADE IN THE USA 

*Read and understand the manual. This manual provides information
and procedures to safely operate and maintain the Quadra-Till.*



Version: 13138 — Serial Numbers 20901-21375

Contents

| | | | |
|--------------------------------------------------|-----------|---------------------------------------------|-----------|
| INTRODUCTION | 5 | HOOK-UP TO TRACTOR | 16 |
| Contact Information | 5 | Safety | 16 |
| SAFETY | 5 | Prior to Connecting Unit | 16 |
| General | 5 | Tow Chain | 17 |
| Safety Alert Symbols | 6 | Connecting to the Tractor | 17 |
| Safety Icons Nomenclature | 7 | OPERATION | 20 |
| Personal Protection/Important Information | 7 | Safety | 20 |
| Prohibited Actions | 7 | Initial Setup | 20 |
| Hazard Avoidance | 7 | MAINTENANCE | 27 |
| General Operating Safety | 8 | Safety | 27 |
| Towing Safety | 8 | Tire and Lug Torque Specifications | 28 |
| Operation Safety | 8 | Bolt Torque Chart | 28 |
| Assembly Safety | 8 | Maintenance Schedule | 28 |
| Maintenance Safety | 8 | Lubrication | 28 |
| COMPONENT NOMENCLATURE | 9 | Wheel Bearings | 28 |
| Component Locations | 9 | Lubrication Points | 28 |
| Component Description | 9 | Hydraulic Components | 30 |
| Disk Gangs (1) | 9 | Safety | 30 |
| Chisel Shanks (2) | 9 | Wheel Lift Cylinders, Disk Gang, and | |
| Rear Leveler Disk Attachment (3) | 10 | Leveler Disk Wing Cylinders | 30 |
| Four-Bar Harrow (4) | 10 | Rear Disk Leveler Cylinders | 30 |
| QT-213F Disk Gang and Leveler Disk Toolbar | 10 | Tire Safety | 30 |
| QT-215F and QT-217F Disk Gang | | Disk Gang Disks | 31 |
| and Leveler Disk Toolbar | 11 | Front Disk Gang Coil Spring System | 31 |
| Disk Gang Gauge Wheels (215F and 217F) | 11 | Chisel Shank Spring Replacement | 32 |
| SPECIFICATIONS | 11 | Chisel Shank Point/Shovel Replacement | 32 |
| Hydraulic Requirements | 11 | TROUBLESHOOTING | 33 |
| Number of Shanks | 11 | STORAGE | 34 |
| Horsepower Range | 11 | Safety | 34 |
| Tillage Depths | 11 | Placing Into Storage (Disk Coatings) | 34 |
| Tongue Weight | 11 | DISPOSAL OF EQUIPMENT AT END | |
| Overall Weight (GVWR) | 11 | OF USEFUL LIFE | 34 |
| Transport Width | 11 | PARTS SECTION | 34 |
| Working Tillage Width (Cut Width) | 11 | Ordering Parts | 34 |
| Towing Speed | 11 | Dealer Contact Information | 34 |
| Instructions for Display of Hazard | | Decals | 34 |
| and Informational Signs | 12 | | |
| ASSEMBLY | 13 | | |
| TOWING | 14 | | |
| General Safety | 14 | | |
| Safety Chain | 14 | | |
| Bystanders | 14 | | |
| Towing and Maximum Towing Speed | 14 | | |
| Highway and Transport Operations | 14 | | |
| Pre-towing Checklist | 15 | | |

| | |
|----------------------------------------------------------------------------|-----------|
| PARTS DRAWINGS | 36 |
| Hitch Frame Assembly | 36 |
| Main Frame Assembly | 38 |
| QT-215F and QT-217F Chisel Frame | 40 |
| Disk Gang Frame Assembly (QT-207 - QT-213F) . | 41 |
| QT-215F and QT-217F Disk Frame | 42 |
| Disk Gang Mounting Hardware | 43 |
| Disk Gang Assembly (All Models) | 44 |
| Folding Disk Mount Tube Assembly (Model QT-213F Rear Only) | 46 |
| Independent Disk Blades | 47 |
| Axle Frame Assembly | 48 |
| Spindle, Hub, and Wheels | 50 |
| Spindle and Hub (Continued) | 51 |
| Chisel Shank Assembly | 52 |
| Leveler Disk Frame Arms | 53 |
| Leveler Disk Assembly | 54 |
| Leveler Disk Frame (QT-207, 209, 211, and 213) . | 55 |
| Leveler Disk Frame (QT-213F, QT-215F, and QT-217F) | 56 |
| 4-Bar Harrow Lift Arm Assembly | 58 |
| 4-Bar Harrow Sections | 59 |
| 3-Bar Harrow Lift Arm Assembly | 60 |
| 3-Bar Harrow Sections | 61 |
| Rolling Basket Assembly | 62 |
| Main Lift Depth Stop Assembly | 63 |
| Lighting and Wiring Harness | 64 |
| Wheel Cylinder Hydraulics | 65 |
| Leveler Disk Hydraulics | 66 |
| Disk Gang Hydraulics | 67 |
| Hydraulic Diagram for QT-213F Wing Fold Cylinders | 68 |
| Hydraulic Diagram for QT-215F and QT-217F Wing Fold Cylinders | 69 |
| CHISEL SHANK LAYOUT DIAGRAM | 70 |
| QT-207 - Shank Frame | 70 |
| QT-209 - Shank Frame | 71 |
| QT-211 - Shank Frame | 72 |
| QT-213 - Shank Frame | 73 |
| QT-213F - Shank Frame | 74 |
| QT-215F - Shank Frame | 75 |
| QT-217F - Shank Frame | 76 |
| ROLLING BASKET LAYOUT DIAGRAM | 77 |
| QT-207 - Rolling Basket Layout | 77 |
| QT-209 - Rolling Basket Layout | 77 |
| QT-211 - Rolling Basket Layout | 78 |
| QT-213F - Rolling Basket Layout | 78 |
| QT-215F - Rolling Basket Layout | 79 |
| QT-217F - Rolling Basket Layout | 79 |
| INDEPENDENT DISK BLADE LAYOUT DIAGRAM | 80 |
| QT-209-I Layout | 80 |
| QT-211-I - Layout | 80 |
| QT-213F-I Layout | 81 |
| QT-215F-I Layout | 81 |
| QT-217F-I Layout | 82 |

| | |
|---------------------------------------------------------------|-----------|
| DEALER CONTACT INFORMATION | 83 |
| WARRANTY | 83 |
| Limited Warranty Statement | 83 |
| Serial Number Location | 83 |
| Warranty Registration Form and Inspection Report | 85 |

Introduction

Thank you for purchasing the McFarlane Quadra-Till Primary Vertical Tillage System. We know that you will get many years of dependable service because McFarlane has been manufacturing quality agricultural equipment since 1936.

A single pass in the fall with the Quadra-Till will leave the soil and residue in a condition that requires only a light pass with a Reel Disk or vertical tillage tool. Using both implements will create the perfect seedbed, saving time, expense, and preparing your fields for spring planting.

The Quadra-Till incorporates field residue up to a ten inch depth for quick breakdown and nutrient deposit. It also prepares the soil so spring field preparation and planting can be done quicker and easier. The Quadra-Till also prepares the ground to promote strong root growth for higher yields.

Quadra-Till provides four tillage functions in a single field pass.

1. Size Residue – Cuts residue into small pieces for faster breakdown.
2. Shatter Soil – Full width fracture of the soil to eliminate compaction layers.
3. Mix Residue – Spreads residue uniformly throughout the profile, ensuring good seed to soil contact in the spring.
4. Levels the Seedbed – Eliminating the need for multiple field finishing passes.

Contact Information

If you have questions not answered in this manual, require additional copies, or the manual is damaged, please contact your local dealer or:

McFarlane Mfg. Co., Inc.
1330 Dallas Street
P.O. Box 100
Sauk City, WI 53583

Phone: (608) 643-3322

Toll Free: (888) 627-8569

Fax: (608) 643-3976

E-mail: info@flexharrow.com

Web: www.flexharrow.com

Safety

General

Safety of the operator and bystanders is one of the main concerns in designing and developing a new piece of equipment. Designers and manufacturers build in as many safety features as possible. However, every year many accidents occur which could have been avoided by a few seconds of thought and a more careful approach to handling the equipment.

Most work related accidents are caused by failure to observe basic safety rules or precautions. An accident can often be avoided by recognizing potentially hazardous situations before an accident occurs. As you assemble, operate, tow, or maintain the Quadra-Till (unit), you must be alert to potential hazards. You should also have the necessary training, skills, and tools to perform any assembly or maintenance procedures.

Improper operation and maintenance of this unit could result in a dangerous situation that could cause injury or death.

WARNING



Do not use or tow the unit until you read and understand the information contained in this manual.



Safety precautions and warnings are provided in this manual and on the unit. If these hazard warnings are not heeded, bodily injury or death could occur to you or to other persons.

McFarlane cannot anticipate every possible circumstance that might involve a potential hazard. The warnings in this manual and on the product are, therefore, not all-inclusive. If a method of operation not specifically recommended by us is used, you must satisfy yourself that it is safe for you and for others. You should also ensure that the unit will not be damaged or be made unsafe by the methods that you choose.

The information, specifications, and illustrations in this manual are based on the information that was available at the time this material was written and can change at any time.

Safety Alert Symbols



This is the safety alert symbol. It is used to alert you to potential personal injury hazards. Obey all safety messages that follow this symbol to avoid possible injury or death.

This manual contains DANGERS, SAFETY INSTRUCTIONS, CAUTIONS, IMPORTANT NOTICES, and NOTES which must be followed to prevent the possibility of improper service, damage to the equipment, personal injury, or death. The following key words call the readers attention to potential hazards.

Hazards are identified by the “Safety Alert Symbol” and followed by a signal word such as “DANGER”, “WARNING”, or “CAUTION”.

DANGER

Indicates an imminently hazardous situation which, if not avoided, will result in death or serious injury. This signal word is limited to the most extreme situations.

WARNING

Indicates a potentially hazardous situation which, if not avoided, could result in death or serious injury.

CAUTION

Indicates a potentially hazardous situation which, if not avoided, may result in minor or moderate injury.

NOTICE

Indicates that equipment or property damage can result if instructions are not followed.

SAFETY INSTRUCTIONS

















Safety instructions (or equivalent) signs indicate specific safety-related instructions or procedures.

NOTE: Contains additional information important to a procedure.

Safety Icons Nomenclature

This manual and the equipment has numerous safety icons. These safety icons provide important operating instructions which alert you to potential personal injury hazards.

Personal Protection/Important Information

-  Read the manual
-  Maintenance procedure
-  Crush hazard
-  Eye protection
-  Hand protection
-  Head protection
-  Hearing protection
-  Inspect equipment
-  OEM parts only
-  Place in neutral
-  Protective shoes
-  Remove key
-  Damaged hazard label
-  Set parking brake
-  Slow vehicle placard
-  Stop engine
-  Support stand usage
-  Use proper tools
-  Visually inspect

Prohibited Actions

-  Do not alter or modify
-  Do not leave out tools
-  Do not weld
-  No alcohol
-  No children
-  No drugs
-  No open flame
-  No passengers
-  No riders
-  No smoking

Hazard Avoidance

-  Block wheels
-  Crushing hazard (body)
-  Crush hazard (foot)
-  Crush hazard (rolling over)
-  Defective or broken part
-  Entanglement hazard
-  Explosive separation hazard
-  Falling hazard
-  Fire hazard
-  High-pressure fluid hazard
-  Hose damage
-  Hot surface

-  Maintain safe distance
-  Overturn hazard
-  Pinch point hazard
-  Pressure alert / check pressure
-  Projectile hazard
-  Safety alert symbol
-  Sharp object hazard
-  Slipping injury
-  Tripping injury
-  Zero pressure

General Operating Safety

WARNING



Read And Understand Manual

To prevent personal injury or even death, be sure you read and understand all of the instructions in this manual and other related OEM equipment manuals! This equipment is dangerous to children and persons unfamiliar with its operation. The operator should be a responsible adult familiar with farm machinery and trained in this equipment's operations. Do not allow persons to operate or assemble this unit until they have read this manual and have developed a thorough understanding of the safety precautions and how it works.

This unit was designed for a specific application; DO NOT modify or use this unit for any application other than which it was designed.

Units operated improperly or by untrained personnel can be dangerous!



Hazard And Information Signs

Replace any missing or hard-to-read decals. Decal placement and part numbers can be found in the Nomenclature section of this manual.



Damaged Parts Hazard

Do not use this unit if it is in need of repair. If you believe the unit has a defect which could cause damage, injury, or death, you should immediately stop using the unit.



Fall Hazard

Do not use the unit as a work platform. Do not stand on top of the unit at any time. Do not ride on the unit or allow others to ride on it.



Entanglement Hazard

Do not wear loose fitting clothing which may become entangled in moving parts.



Crush Hazard (Rolling Over)

When disconnecting the unit or leaving the operator's seat:

1. Stop the tractor or towing vehicle.
2. Shut off the engine and remove the ignition key.
3. Set the brakes.
4. Make sure wheel cylinder transport locks are attached.
5. Relieve hydraulic fluid pressure.
6. If parking the unit, make sure jack stand is lowered and retaining pin is installed.



Injury Hazard

Do not permit children to play on or around the stored unit.

WARNING



Impaired Operator Hazard

Do not attempt to operate this unit under the influence of drugs or alcohol. Review the safety instructions with all users annually.

Personal Protection Equipment

When working around or operating this unit, wear appropriate personal protective equipment. This list includes but is not limited to:



- A hard hat
- Protective shoes with slip resistant soles
- Protective goggles, glasses, or face shield
- Heavy gloves and protective clothing



Safe Distance

Keep all bystanders, especially children, away from the unit while in operation.

SAFETY INSTRUCTIONS



To prevent injury, use a tractor equipped with a Roll Over Protective System (ROPS).



Visually Inspect

Visually inspect the unit for any loose bolts, worn parts, or cracked welds, and make necessary repairs before using the unit.

Towing Safety

For towing safety information, refer to the Towing section.

Operation Safety

For operating safety information, refer to the Operation section.

Assembly Safety

For assembly safety information, refer to the separate Assembly manual.

Maintenance Safety

For maintenance safety information, refer to the Maintenance section.

Component Nomenclature

Component Locations

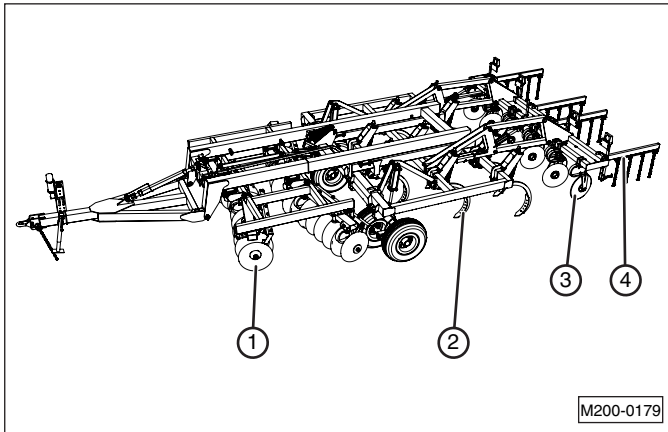

The Quadra-Till is comprised of four components: the double disk gangs (1), the chisel shanks (2), the leveler disks (3), and the four-bar harrow (4).

Component Description

Disk Gangs (1)

The disk gangs cut the residue, open the soil surface, and begin the process of incorporating the residue into the soil up to four inches deep. Adjusting the angle and depth of the disk gangs is the first step in sizing and incorporating the residue.



The depth of the disk gang is adjusted hydraulically with a cylinder. The disk gang depth ranges from 0 to 4 inches. The depth of the disk is normally determined by the amount of residue and the field conditions. The deeper the setting the more residue is incorporated into the soil.

The angle of the disk gang can be set in any one of three settings. To incorporate the maximum amount of residue, set the disk gang angle to the most aggressive setting of #3. If residue and sizing are not an issue (like soybean ground) then the disks should be set to the #1 setting and the disks set as shallow as possible.

NOTICE

In high residue situations, maximum down pressure on the disks is required to more completely cut the residue. Make sure the C-spring stop does not constantly contact the frame, as this will cause equipment damage.



Chisel Shanks (2)



The chisel shanks perform two tasks; they shatter the soil and incorporate the residue. The chisel shanks incorporate the residue evenly in the top of the profile, which is extremely important in vertical tillage. Too much residue in the top two to three inches of the profile causes poor soil-to-seed contact, which results in uneven germination.

The chisel shanks are also designed to shatter the soil evenly across the profile so any compaction layers are broken up. The shank configuration and spacing are set to provide the best soil breakup and uniformity.

Depth adjustment for the chisel shanks uses a depth stop which contacts a control valve located at the front of the machine on the main frame. This valve controls the position of the wheel lift cylinders. Since this moves the whole machine up or down, the other components need to be checked and possibly readjusted any time the shank depth changes. The optimum working depth of the chisel shanks is 6 to 12 inches.

Besides the depth setting, the operating characteristics of the chisel shanks can be changed by the use of different points or shovels. The unit is shipped with three inch twisted shovels as standard equipment. An optional four inch twisted shovel is available which will move more dirt and incorporate more residue. Also, an optional two inch straight point is available which incorporates less residue and requires less horsepower.

Spring Protection

Each chisel shank is equipped with a spring to protect it from breaking in the event it hits something, such as a rock. The spring tension is preset at the factory and no adjustment is necessary.



Rear Leveler Disk Attachment (3)



The rear leveler disks are designed to level the ridges left by the chisel shanks. They should be set low enough to level the ridges, but not too deeply as they can create furrows.

The rear leveler disks are adjusted with dual hydraulic cylinders that move the rear section of the unit up or down. Controls within the tractor cab allow the operator to adjust the depth while moving across the field.

Four-Bar Harrow (4)



The four-bar harrow is used to break up clods of soil and disperse the residue evenly across the work area.

There are three attachment points for the pull chains on the harrow section. Moving it up will cause the section to lay more flat (less aggressive) and moving it down will cause the teeth to stand up more straight (more aggressive).

In some situations that do not require the extra leveling of the harrow section, such as heavy fall residue, the sections can be removed.

QT-213F Disk Gang and Leveler Disk Toolbar

The model QT-213F is equipped with a fold-out disk gang and leveler disk toolbar which decreases the transport width to 16'4" (4.98 m).

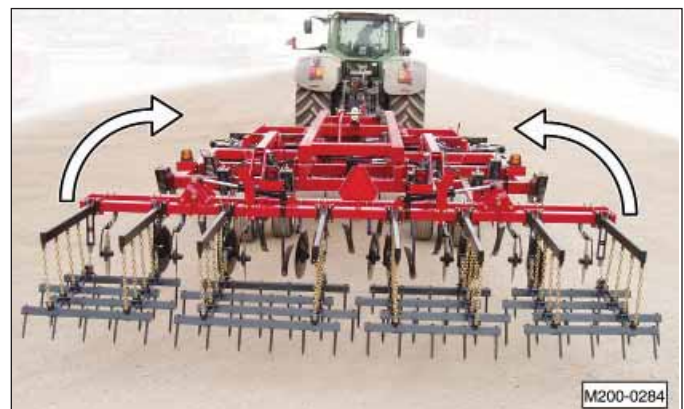

QT-215F and QT-217F Disk Gang and Leveler Disk Toolbar

The QT-215F and QT-217F models are equipped with a fold-out disk gang and leveler disk toolbar which decreases the transport width to 16'2" (4.93 m).



Disk Gang Gauge Wheels (215F and 217F)



The gauge wheels help to carry the weight of the chisel frame wing. They are not designed to limit or set the working depth of chisel.

Specifications

Hydraulic Requirements

This unit operates with hydraulic pressures of 2500 to 3000 psi (170 to 205 bars).

Number of Shanks

QT-207 — 7
QT-209 — 9
QT-211 — 11
QT-213 — 13
QT-213F — 13
QT-215F — 15
QT-217F — 17

Horsepower Range

QT-207 — 175 to 210
QT-209 — 225 to 270
QT-211 — 275 to 330
QT-213 — 325 to 390
QT-213F — 325 to 390
QT-215F — 375 to 450
QT-217F — 425 to 510

Tillage Depths

- Disk gang depth up to 4" (10.2 cm)
- Chisel shank depth 6 to 12" (15.2 to 30.5 cm)
- Rear Leveler disk depth is hydraulically adjustable to match operating depth

Tongue Weight

Tongue weight of the unit is approximately 700 lbs. (318 kgs)

Overall Weight (GVWR)

QT-207 — 13,291 (6029 kg)
QT-209 — 14,497 (6576 kg)
QT-211 — 16,763 (7604 kg)
QT-213 — 18,309 (8305 kg)
QT-213F — 19,089 (8559 kg)
QT-215F — 24,840 (11,267 kg)
QT-217F — 26,500 (12,020 kg)

Transport Width

QT-207 — 12'8" (3.86 m)
QT-209 — 13'8" (4.17 m)
QT-211 — 17'3" (5.26 m)
QT-213 — 19'1" (5.82 m)
QT-213F — 16'4" (4.98 m)
QT-215F — 16'2" (4.93 m)
QT-217F — 16'2" (4.93 m)

Working Tillage Width (Cut Width)

QT-207 — 8'9" (2.67 m)
QT-209 — 11'3" (3.43 m)
QT-211 — 13'9" (4.19 m)
QT-213 — 16'3" (4.95 m)
QT-213F — 16'3" (4.95 m)
QT-215F — 18'9" (5.72 m)
QT-217F — 21'3" (6.48 m)

Towing Speed

Towing speeds should not exceed 20 MPH (32 KPH)
Field operating speeds should be 5 to 6-1/2 MPH (8 KPH to 10-1/2 KPH)

Instructions for Display of Hazard and Informational Signs

- It is the responsibility of the customer to know the lighting and marking requirements of the local highway authorities and to install and maintain the equipment to provide compliance with the regulations. Add extra lights when transporting at night or during periods of limited visibility.
- Keep safety signs clean and legible at all times. Replace safety signs that are missing or have become illegible.
- Do not paint over, remove, or deface any safety signs or warning decals on your equipment. Observe all safety signs and practice the instructions on them.
- Replacement parts that display a safety sign should display the same sign.
- Make sure the hazard warning labels or other information decals are legible and attached to the unit before use.
- Safety signs are available from your Distributor, Dealer Parts Department, or the factory.

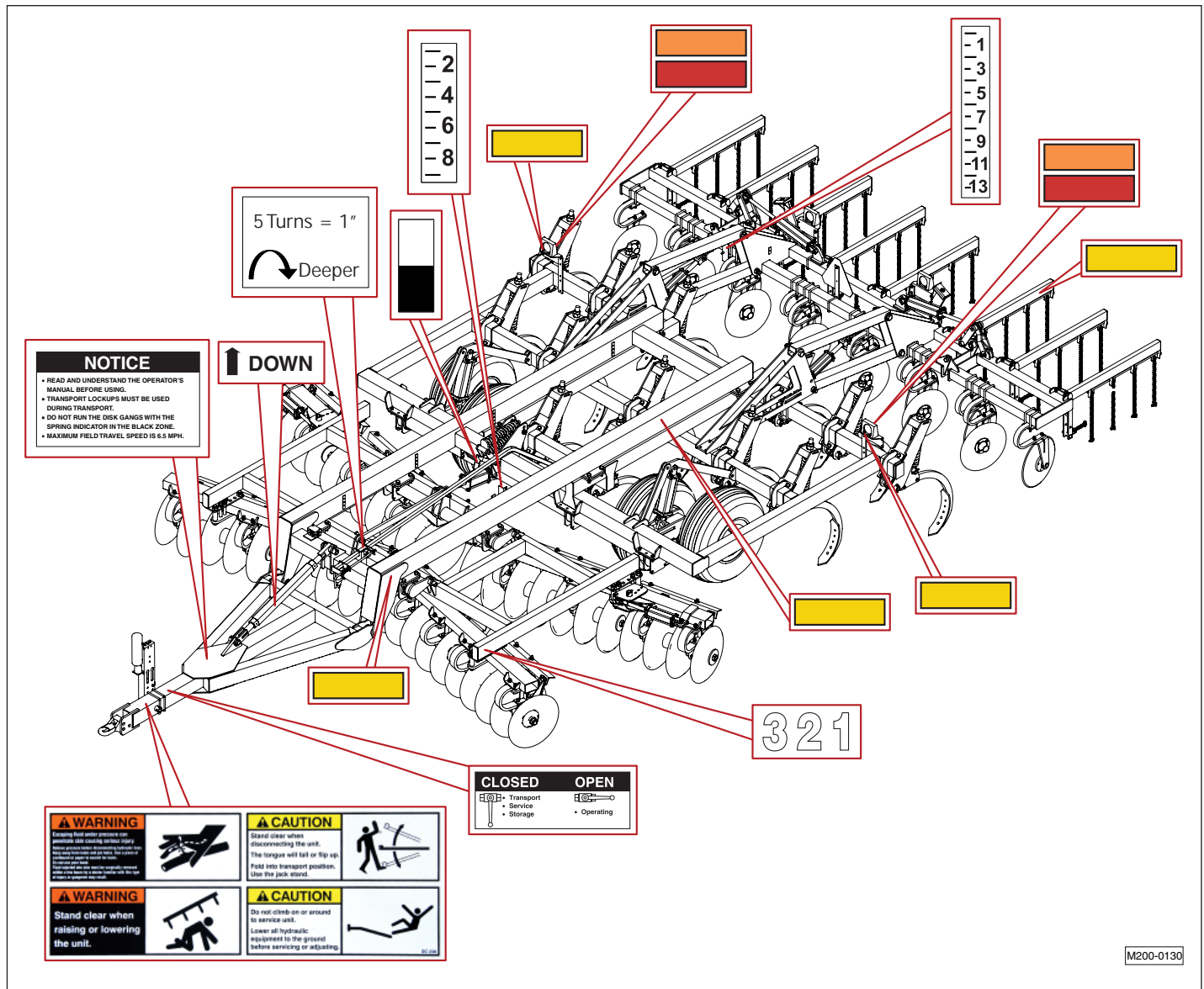

⚠ WARNING

Escaping fluid under pressure can penetrate skin causing serious injury. Relieve pressure before disconnecting hydraulic lines. Keep away from leaks and pin holes. Use a piece of cardboard or paper to search for leaks. Do not use your hand. Fluid injected into skin must be surgically removed within a few hours by a doctor familiar with this type of injury or gangrene may result.



⚠ WARNING

Stand clear when raising or lowering the unit.



⚠ CAUTION

Stand clear when disconnecting the unit. The tongue may fall or flip up. Fold into transport position. Use the jack stand.



⚠ CAUTION



Do not climb on or around to service unit. Lower all hydraulic equipment to the ground before servicing or adjusting.



DC 230

NOTICE

- READ AND UNDERSTAND THE OPERATOR'S MANUAL BEFORE USING.
- TRANSPORT LOCKUPS MUST BE USED DURING TRANSPORT.
- DO NOT RUN THE DISK GANGS WITH THE SPRING INDICATOR IN THE BLACK ZONE.
- MAXIMUM FIELD TRAVEL SPEED IS 6.5 MPH.

| | |
|-----------------------------------------------------------------------------------------------------------------------------------------------------------------------------------------|---------------------------------------------------------------------------------------------------------------------------------------------------|
| CLOSED | OPEN |
|  <ul style="list-style-type: none"> • Transport • Service • Storage |  <ul style="list-style-type: none"> • Operating |
| DC230b | |



Assembly

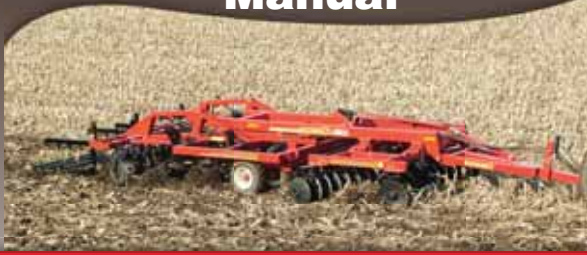

Refer to the Quadra-Till Assembly manual for complete instructions.

Assembly Manual



McFARLANE
QUADRA-TILL
200 Series
SIZES, SHATTERS, MIXES, & LEVELS



Read and understand the manual. This manual provides information and procedures to safely operate and maintain the Quadra-Till.



Version: MFA-0903

Towing

General Safety

SAFETY INSTRUCTIONS

 Towing the Quadra-Till requires care! Both the unit and tow vehicle must be in good working condition. Securely attach to towing unit. Use a high strength, appropriately sized hitch pin with a mechanical retainer and attach safety chain.

 Make sure the hitch and coupling on the towing vehicle are rated equal to, or greater than, the unit's "gross vehicle weight rating" (GVWR). Refer to the specification section.

 Make sure the safety chain is securely fastened to the tow vehicle.

 Check the tires for tread wear, inflation pressure, and overall condition.

 Inspect the hitch and coupling for wear or damage. DO NOT tow the unit using a defective hitch or coupling!

 Make sure directional, brake, and running lights are connected and working properly.

 Make sure the lug nuts holding the wheels are tight (torque to specifications) and that none are missing.



 When towing the unit on the highway, make sure the "Slow Moving Vehicle" placard is clearly visible.

 Do not allow anyone to stand between the tongue or hitch and the towing vehicle when backing up to the equipment.

 Make sure that the area is clear of children, animals, and other obstacles before using.



Safety Chain

SAFETY INSTRUCTIONS

- If the unit will be transported on a public highway, the safety chain must be attached to the tow vehicle.
-  Always follow state and local regulations regarding a safety chain when towing farm equipment on a public highway.
-  Be sure to check with local law enforcement agencies for any local regulations or restrictions.
- Do not use any device other than the safety chain that was supplied with the unit. Only a safety chain (not an elastic or nylon/plastic tow strap) should be used to retain the connection between the tow vehicle and the unit in the event of separation of the primary attaching system.

Bystanders

SAFETY INSTRUCTIONS

-  Beware of physical surroundings and especially bystanders, particularly children, before moving the unit! This is particularly important with higher noise levels and quiet cabs, as you may not hear people shouting.
-  NO PASSENGERS ALLOWED - Do not carry passengers anywhere on or in the tractor, except as required for operation.
-  Do not allow anyone to ride on the unit while it is moving.

Towing and Maximum Towing Speed

SAFETY INSTRUCTIONS

- Operate the towing vehicle from the operator's seat only.
- Do not exceed a towing speed of more than 20 mph (0.5 KPH) on a public roadway.
-  Remember, tires supplied by the manufacturer are designed to operate LESS THAN 20 mph. Do not exceed or tire failure may occur.

Highway and Transport Operations

SAFETY INSTRUCTIONS

- Make sure the wheel cylinder transport locks are installed and the jack stand is in its storage position before transporting the unit.

SAFETY INSTRUCTIONS

- Never use independent braking with unit in tow as loss of control and/or upset of unit may result.
- Always drive at a safe speed relative to local conditions and ensure that your speed is low enough for an emergency stop to be safe and secure. Keep speed to a minimum.
- Reduce speed prior to turns to avoid the risk of overturning.
- Avoid sudden uphill turns on steep slopes.
- Always keep the tractor or towing vehicle in gear to provide engine braking when going downhill. Do not coast.
- Use approved accessory lighting flags and necessary warning devices to protect operators of other vehicles on the highway during daylight and nighttime transport. Various safety lights and devices are available from your dealer.
- The use of flashing amber lights is acceptable in most localities. However, some localities prohibit their use. Local laws should be checked for all highway lighting and marking requirements.
- When driving the tractor and equipment on the road or highway, use flashing amber warning lights and a slow moving vehicle (SMV) identification emblem.
- Be a safe and courteous driver. Always yield to oncoming traffic in all situations, including narrow bridges, intersections, etc. Plan your route to avoid heavy traffic.
- Be observant of bridge loading ratings. Do not cross bridges rated lower than the gross weight at which you are operating.
- Watch for obstructions overhead and to the side while transporting.
- Always operate equipment in a position to provide maximum visibility at all times. Make allowances for increased length and weight of the equipment when making turns, stopping, etc.

Pre-towing Checklist

1. Before towing, make sure the maintenance on the tractor and the unit are current. This is very important because towing puts additional stress on the tow vehicle.
2. Check and correct the tire pressures on the tow vehicle and the unit. Refer to the Tire and Lug Torque specification chart in the manual.
3. Make sure the hitch, coupler, and any other equipment that connects the unit and the tow vehicle are properly secured and adjusted. Always inspect the hitch and tongue for cracks when hooking up.

! WARNING

! Substandard Parts Hazard
If towing the unit with a draw bar, use only an OEM certified, hardened drawbar pin with a retainer clip. Do not use homemade pins, bolts, or any other type of retaining device. Always install the retainer clip, making sure the hitch and unit are securely fastened to the tow vehicle.

Using a pin not intended for this type of towing, can result in unexpected separation of the unit from the tow vehicle resulting in equipment damage and personal injury.

4. Verify the appropriate Category 3 (7 shank) or Category 4 (9, 11, 13, 15, 17 shank) hitch is installed.



Model 207

Models 209 - 217F

⚠️ WARNING

⚠️ Unexpected Separation Hazard
If the safety chains do not have a current certification tag, do not use the unit until properly certified chains are installed. Substandard safety chains could allow the unit to separate from the tow vehicle resulting in equipment damage and personal injury.

5. Attach the safety chain from the unit to the tow vehicle. The safety chain should be long enough for tight turns. Don't allow the chain to drag on the pavement because it will wear the chain links causing an unsafe condition.
6. Make sure the electrical wiring harness for the running and taillights is properly connected and not touching the road, but loose enough to make turns without disconnecting or damaging the wires.
7. Have an observer confirm all running lights, brake lights, turn signals, and hazard lights are working on both the tow vehicle and the unit.
8. Verify the brakes on the tow vehicle are operating correctly.
9. Make sure transport locks are securely fastened to the cylinders and the hydraulic lock valve is in the closed position.
10. Make sure the jack stand is raised and locked in the storage position.
11. Check mirrors of the tow vehicle to make sure you have good visibility.
12. Check routes and restrictions on bridges and tunnels.

Hook-Up to Tractor



Safety

SAFETY INSTRUCTIONS



Make sure that anyone who will be operating the unit or working on or around the unit reads and understands all the operating, maintenance, and safety information in the operator's manual and other related OEM equipment manuals before using or towing the unit.

Prior to Connecting Unit

Make sure the unit is resting on the ground or the transport locks are securely installed over the wheel cylinders before attaching the unit to the tractor.



SAFETY INSTRUCTIONS



If the unit is not resting on the ground, make sure wheel chocks are securely fitted on both sides of each wheel.

WARNING



Crush Hazard

The tongue weight of the unit is approximately 700 lbs. (318 kgs.). Use care when lifting or attaching the unit to the tractor. Never place any part of your body under the tongue or hitch assembly.



Hydraulic Pressure

This unit operates with hydraulic pressures of 2500 to 3000 psi (170 to 205 bars).



High-Pressure Fluids

1. Check or tighten all connections BEFORE pressurizing system.

2. Release all pressure before removing hoses and/or valves by:

a. Stopping engine.

b. Holding hydraulic control levers in float or neutral position.



3. DO NOT use your bare hand to check for potential leaks. Always use a board or cardboard when checking for a leak.

Escaping hydraulic fluid under pressure, even a pinhole size leak, can penetrate body tissue, causing serious injury and possible death. If fluid is injected into your skin, it must be treated immediately by a doctor familiar with this type of injury.

Tow Chain



A certified tow chain is supplied with each unit. This chain must be attached to the tractor during towing or operation of the unit.

SAFETY INSTRUCTIONS



Inspect the chain annually for wear or damage.



Do not replace the chain with anything other than an OEM certified replacement.

Connecting to the Tractor

1. Raise the jack stand and connect the tongue to the tractor. The tongue weight of the unit is approximately 700 lbs. (318 kgs).

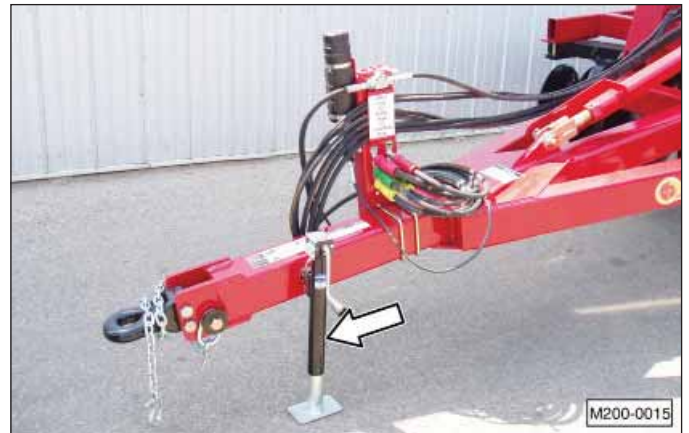

Note: If a drawbar pin is used, it should be an OEM certified pin and retainer clip. On Model QT-207, category 3 pintle hitch use a 1-1/2" (38 mm) pin. On Model QT-207, category 3 clevis hitch use a 1-1/4" (32 mm) pin. On Models QT-209, QT-211, QT-213, QT-213F, QT-215F, and QT-217F category 4 pintle hitch use a 2" (51 mm) pin.



2. Connect the hitch of the unit to the tractor. Attach the tow chain to the tractor's draw bar cage.

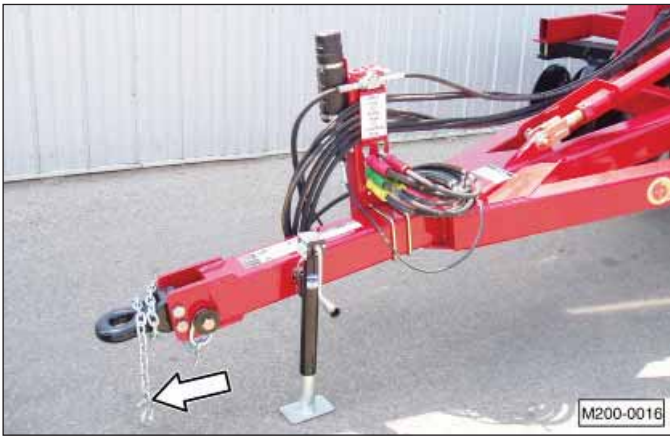

Note: When connected, make sure the retaining plate securely locks the chain link in place.



3. Remove the jack stand in place it in its storage position inside the frame, as shown.



4. Remove the six hydraulic hoses from their storage position.



5. Connect the six hydraulic hoses to the tractor.

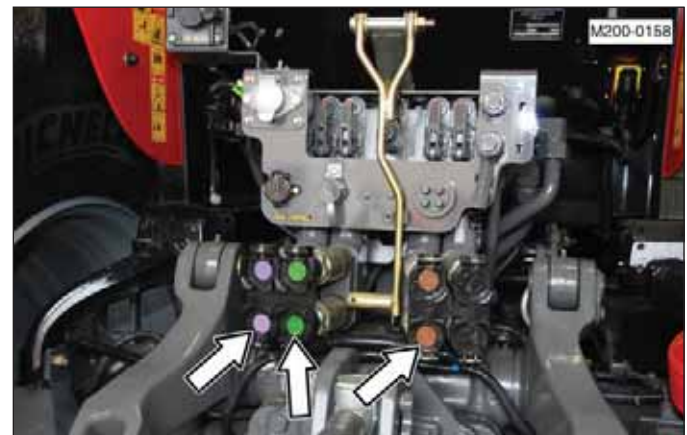

Note: The most commonly used function of the unit is the "main lift" cylinders, which raises and lowers the wheels. Connect the hydraulic hoses for this function into the port (control lever) used most commonly.

6. Disconnect the electrical connection for the rear lights from the storage socket.



a. Rotate the plug.



b. Push the plug upward and slightly rotate it again to release it from the socket.



c. Pull the plug downward.



d. Connect the plug into the tractor's electrical socket.



7. Make sure all the hydraulic cylinders are functioning properly.
8. Make sure the amber and red indicator lights are working properly.
9. Move the unit to the desired location and position it for operation following the towing recommendation provided in this manual and/or any other local, State, or Federal regulations that may apply.

Operation



Safety

WARNING

To prevent serious injury or death, follow these safety instructions

 Entanglement Hazard
Keep hands and clothing clear of moving parts.

 Crush Hazard (Rolling Over)
Do not clean, lubricate, or make adjustments while the unit is moving.

   Crush Hazard (Rolling Over)
When making adjustments to the unit or leaving the operator's seat:

1. Stop the tractor.
2. Shut off the engine and remove the ignition key.
3. Set the brakes.

 Overturn Hazard
Pick the levellest possible route when transporting across fields. Avoid the edges of ditches or gullies and steep hillsides.

 Safe Distance
Keep all bystanders, pets, and livestock clear of the work area, particularly when raising or lowering the unit.

SAFETY INSTRUCTIONS

 Periodically clear the unit of brush, twigs, or other materials to prevent buildup of dry, combustible materials.

NOTICE

DO NOT turn while the unit is in the ground.

DO NOT operate the unit in frozen ground.

Initial Setup

The McFarlane Quadra-Till is a tool that is designed to handle a wide variety of field conditions. It has many adjustments that can be made to change the performance of each component on the unit as well as its overall performance. Achieving the best results over the widest range of circumstances can be accomplished by making adjustments to match the field conditions.

Note: It is important to make one adjustment at a time in order to see the results of each change. If several adjustments are made at the same time, the operation of the machine can change dramatically, creating confusion and frustration.

1. If necessary, remove the transport locks from both wheel cylinders. Store the transport locks in their storage positions on the frame, as shown.



⚠ WARNING



Pinch Point Hazard

Do not place hands or fingers between moving and/or stationary parts. The weight of the unit will easily cause serious bodily injury.



Sharp Object Hazard

Do not place any part of your body under the disk gang during the adjustment process. Severe injury will occur if a person contacts or falls under the disk gang.

2. Adjust the disk gang angle by repositioning the retainer bolts (1) and moving the disk gang into the desired position using the following procedure. The photo shows the disk gang set in the #2 position.



Note: On QT-213F, QT-215F, and QT-217F models, make sure the disk gang wing is unfolded before starting the adjustment procedure.

- a. Lower the disk gang close to the ground but not touching.



Do not place any part of your body under the disk gang.

- b. Move the handle of shut-off valve (2) to the closed position, as shown. The shut off valve helps prevent the wheel cylinders from retracting, due too bleed off within the hydraulic system, resulting in the disk gang lowering to the ground.



⚠ WARNING

To prevent serious injury or death from rolling over or crushing during the setup procedure:



Stop tractor's engine.



Set parking brake.

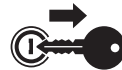

Remove ignition key.



Block wheels of unit.

- c. Stop the tractor, shut off the engine, set the parking brake, and remove the ignition key from the tractor.
- d. Block the wheels of the unit to prevent movement during repositioning of the disk gangs.
- e. Remove two retainer clips (3) from the castle nuts and remove the castle nuts using the wrench supplied with the unit.



Adjustments for rear disk gang.



f. Adjust the disk gang to the desired angle.

The #2 position is a neutral setting and a good place to start the initial setup.

The #1 position is the least aggressive setting and is typically used with higher speeds and smaller amounts of residue.

The #3 position is the most aggressive setting and is used for heavy or difficult residue. This setting also requires the most horsepower. It may also be necessary to reduce the speed at this steeper gang angle to prevent ridging.

g. Set the remaining disk gangs to the same position. Replace two retaining bolts (1), install and tighten the castle nuts to a snug fit, and install two retainer clips (3).



Adjustments for front disk gang.

3. Start the tractor and use the control lever to raise the complete unit (lower wheels).
4. Use the control lever for the front disk unit and raise the disk to the maximum height. On QT-213F, QT-215F, and QT-217F models unfold the disk gang wing, if not already extended.

5. Using the tractor's control lever for the leveler disk and harrow assembly, raise it to the maximum height. On QT-213F, QT-215F, and QT-217F models lower the leveler disk wings, if not already lowered.
6. Begin to pull the unit through the field.
7. Using the tractor's control lever for the main lift (controls wheel depth), slowly raise the wheels until the chisel shanks contact the ground.



8. Continue raising the wheels (lowering the unit) until the chisel shanks are approximately 6 to 12 inches (15.2 to 30.5 cm) in the ground.

Note: On the initial set up of the QT-215F and QT-217F, raise the gauge wheels to the highest position. Once the chisel depth is set, the gauge wheels can be adjusted into the working position.

9. Stop the tractor with the unit still in the ground.

⚠ WARNING



Before leaving the tractor, shut off the engine, set the parking brake, and remove the ignition key.

10. Measure the depth the chisel shank is cutting into the ground.
11. Adjust the chisel shank stop mechanism (1) until stop plate (2) contacts the plunger of the hydraulic flow shut off valve (3).

Note: The desired depth of the chisel shanks is controlled by hydraulic valve (3). When the wheels of the unit are raised, stop plate (2) attached to the frame actuates the valve, stopping oil flow. Each time the wheels are raised and lowered, the valve will consistently position the depth of the chisel shanks.

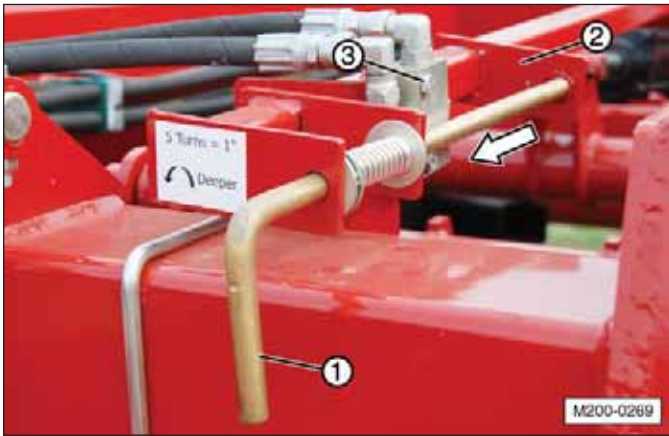

12. If the chisel shanks need to be set lower, adjust the stop mechanism accordingly. Five full turns of the crank equals 1 inch of depth adjustment.

Note: Since the wheels position the height of the entire frame of the unit, the depth setting of the other components also needs to be checked and possibly readjusted any time the chisel shank depth is changed.

13. Continue pulling the unit through the field and raise and lower the chisel shanks to allow the hydraulic control valve to stop at the set depth. Stop the tractor and check the depth of the chisel shanks, making sure they are the desired depth. Readjust the depth control device, if necessary.

⚠ WARNING



Before leaving the tractor, shut off the engine, set the parking brakes, and remove the ignition key.

14. Once the desired depth is reached for the chisel shanks, the unit must be leveled by adjusting the frame leveling turnbuckle. Stop the unit with the chisel shanks in the ground.



a. Raise the locking mechanism from the turnbuckle.

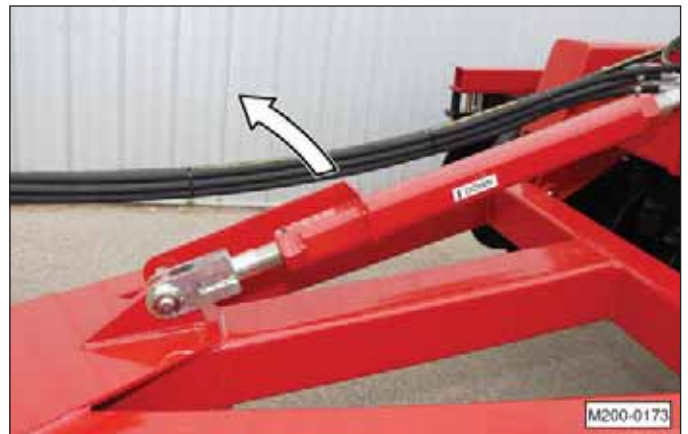

b. Use the wrench (stored on a bracket on the main frame) to make the adjustment.



- c. As viewed from the front of the unit, turning the turnbuckle counterclockwise will raise the hitch end and lower the harrow end.



- d. Check for level. Adjust the turnbuckle as needed.



- e. Once the unit is level from front to back, place the locking mechanism over the turnbuckle.



Note: When a major change is made to the depth of the front gang disks, the chisel shanks, or the rear leveler disks, make sure the frame is still level.

- 15. Position the chisel shank frame gauge wheels (QT-215F and QT-217F only).

- a. With the chisel shanks in the ground at the desired depth, lower the gauge wheels to SLIGHTLY carry the weight of the chisel frame wings.

Note: The gauge wheels are not designed to prevent the chisel from working deeper than originally set.

- b. Once both gauge wheels have been set to the same depth, install the lock pin.

Note: The gauge wheels must be readjusted whenever the chisel depth is changed.



- 16. Continue pulling the unit through the field and using the disk gang depth control lever, begin lowering the disk gangs until they start cutting 1 to 2 inches (25 to 50 mm) into the ground. Adjust the position of the disk gangs to the desired depth using the depth gauge (1) (one through nine) and depth indicator (2).



Note: If depth gauge (1) indicates a level of four and you need to lower the unit an additional 2 inches (51 mm), move indicator (2) down to number six.

Note: The disk gangs should not be run deeper than 4 inches (102 mm). If more soil loosening is required, increase the aggressiveness of the disk gang angle.

The disk gangs and their frame are protected by a heavy-duty spring protection device with a down-pressure indicator. If indicator arrow (1) is in the "black" zone (3) (too much pressure), raise the disk gang or change the angle until the indicator is in the "white" zone (2) (proper operating pressure).

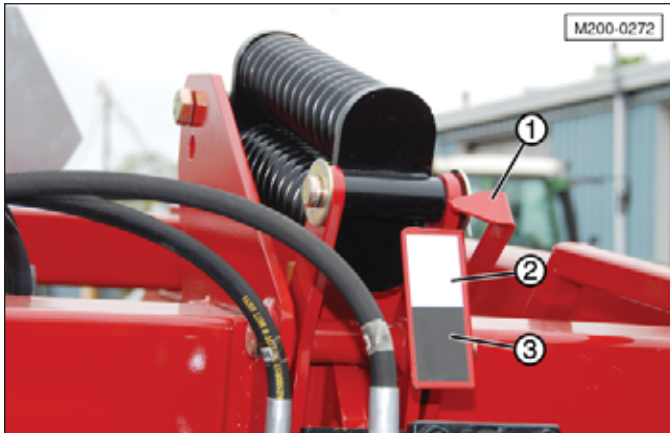

17. Using the leveler disk control lever and the leveler disk indicator (1 through 11), lower the leveler disks to approximately a finished grade level.



18. Once the proper height of the leveler disk is set, insert the cylinder rod stops from their storage location and place them on the cylinder rod between the body of the cylinder and the clevis, as shown.



Note: Inserting the cylinder rod stop collars allows the leveler disks to be raised and then lowered again to the exact same position every time. They also prevent the cylinders from retracting due to bleed off within the hydraulic system.

19. Finally, once the front disk gangs, chisel shanks, and rear leveler disks have been set to the desired depth, recheck the frame for level. Adjust the turnbuckle, if necessary.

20. Adjust chain length for harrow.



21. Adjust the rolling basket height and tension, if equipped.

- a. Place the rolling basket on a flat, level surface.
- b. Loosen jam nut (1) at the front of adjusting bolt (2).

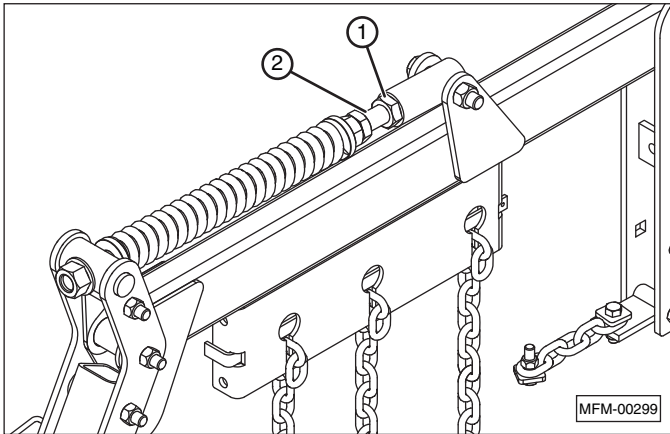

- c. Turn the adjusting bolt to either raise or lower the rolling basket. Do not change the tension on the spring. Set the rolling basket height so it just touches the ground.

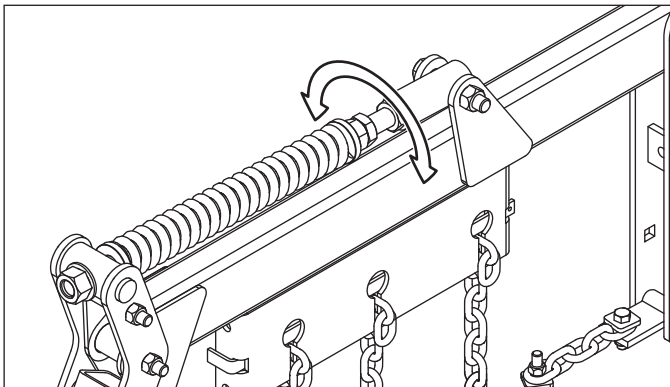

- d. Make sure all the rolling baskets are adjusted to the same height. Failure to do so will result in uneven seedbed conditions and could damage the rolling basket arms and/or bearings.

If desired, the hitch pin can be removed and placed below the pivot arm to run the baskets in a floating position. This will help prevent plugging in wet soil conditions.

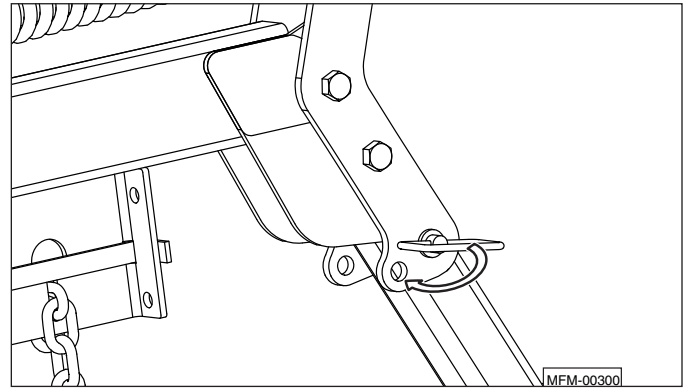

To maximize the unit's performance, it should be operated at speeds ranging from 5 to 6-1/2 mph (8 to 10-1/2 kph). This keeps the field debris moving through the harrow sections and avoids clogging.

The unit should now be ready.

Maintenance

Safety

WARNING

To prevent serious injury or death:



Rolling Over /
Crush Hazard

To prevent serious injury or death, before servicing, adjusting, repairing, or performing other work on the unit, always make sure the tractor or towing vehicle engine is stopped, the ignition key is removed, the unit is lowered to the ground, all controls are placed in neutral, the parking brake is set, and all hydraulic fluid pressure is relieved (zero pressure).



Rolling Over Hazard
Block the wheels before performing maintenance or repairs.



Use Properly Rated Tools
Use sufficient tools, jacks, and hoists that have the capacity for the job.



Crush Hazard
Use support blocks or safety stands rated to support the load when changing tires or performing maintenance.



High-Pressure Fluids
Never use your hands to locate a hydraulic leak. Use a piece of cardboard or wood. Wear proper hand and eye protection when searching for a high-pressure hydraulic leak.

Hydraulic fluid escaping under pressure can penetrate the skin. Openings in the skin and minor cuts are susceptible to infection from hydraulic fluid. If injured by a concentrated high-pressure stream of hydraulic fluid, seek medical attention immediately. Without immediate medical treatment, serious infection or toxic reaction can develop if hydraulic fluid penetrates the surface of the skin.



Entanglement Hazard
Keep hands, feet, clothing, jewelry, and long hair away from any moving parts to prevent them from getting caught.

SAFETY INSTRUCTIONS

Follow all operating, maintenance, and safety instructions found in this manual.



Understand the service procedure before performing the work. Keep area clean and dry.



Replace all worn or damaged safety and instruction decals.



Keep all parts in good condition and properly installed. Fix damage immediately. Replace worn or broken parts.



Do not leave tools lying on the unit.



Do not modify machine or safety devices. Do not weld on the unit. Unauthorized modifications may impair its function and safety.

If equipment has been altered in any way from the original design, the manufacturer does not accept any liability for injury or warranty.



Never replace hex bolts with less than Grade 5 bolts unless otherwise specified.





Where replacement parts are necessary for periodic maintenance and servicing, genuine factory replacement parts must be used to restore the unit to original specifications. The manufacturer will not claim responsibility for damages as a result of the use of unapproved parts.

Tire and Lug Torque Specifications

| Model | Tire Size | Ply Rating | Tire Pressure | Lug Size | Lug Torque (lb.ft.) | | Weight (lbs.) |
|--------------------------------|--------------|------------|---------------|----------|---------------------|-----|---------------|
| | | | | | Min | Max | |
| QT-207 | 16.5L-16.1 | 14 ply | 48 psi | 5/8" | 85 | 100 | 170 |
| QT-209 | IF 320/70R15 | — | 38 psi | 9/16" | 80 | 90 | 102 |
| QT-211 | IF 320/70R15 | — | 52 psi | 5/8" | 85 | 100 | 102 |
| QT-213 / QT-213F | 14L-16.1 | 14 ply | 52 psi | 5/8" | 85 | 100 | 124 |
| QT-215F | 16.5L-16.1 | 14 ply | 64 psi | 5/8" | 85 | 100 | 170 |
| QT-217F | 16.5L-16.1 | 20 ply | 64 psi | 5/8" | 85 | 100 | 121 |
| QT-215F and QT217F Gauge Wheel | 9.5L-15 | 8 ply | 44 psi | 1/2" | 75 | 85 | 78 |

Bolt Torque Chart

| Bolt Head Markings |  No Marking | |  3 Radial Lines | |  6 Radial Lines | |
|--------------------|-------------------------------------------------------------------------------------------------|-----------------------------|-----------------------------------------------------------------------------------------------------|-----------------------------|-------------------------------------------------------------------------------------------------------|-----------------------------|
| | Bolt Diameter | SAE Grade 2 N·m (ft-lbs) | | SAE Grade 5 N·m (ft-lbs) | | SAE Grade 8 N·m (ft-lbs) |
| 1/4" | 8 | (6) | 12 | (9) | 17 | (12) |
| 5/16" | 13 | (10) | 25 | (19) | 36 | (27) |
| 3/8" | 27 | (20) | 45 | (33) | 63 | (45) |
| 7/16" | 41 | (30) | 72 | (53) | 100 | (75) |
| 1/2" | 61 | (45) | 110 | (80) | 155 | (115) |
| 9/16" | 95 | (70) | 155 | (115) | 220 | (165) |
| 5/8" | 128 | (95) | 215 | (160) | 305 | (220) |
| 3/4" | 225 | (165) | 390 | (290) | 540 | (400) |
| 7/8" | 230 | (170) | 570 | (420) | 880 | (650) |
| 1" | 345 | (225) | 850 | (630) | 1320 | (970) |

Maintenance Schedule

- After the first 12 hours of use, check the tightness of the bolts, especially those on the C-springs. Torque specifications are listed in the Bolt Torque Chart in this manual.
- Prior to each use, check for loose bolts and replace lost or worn parts.
- Grease hinge pins every 15 hours.
- Grease wheel bearings every 50 hours (sparingly) and check for endplay. Repack annually.
- On units equipped with individual disk hubs, grease disk hub bearings every 50 hours (sparingly) and check for endplay. Repack annually.

Note: Clean grease fittings and replace those that are broken or missing. Over greasing may damage bearing seals and cause premature bearing failure.

Lubrication

Wheel Bearings

Wheel bearings and disk hub bearings only require lubrication every 50 hours of service. These bearings should be greased sparingly every 50 hours of service. Check for end play in the bearings, prior to adding grease.

Clean, repack, and adjust the wheel bearings and leveler disk bearings annually. Use only wheel bearing grease when repacking these units.

Lubrication Points

Add grease to the locations shown on the following page.

When greasing a pin and bushing, add grease until it is visibly forced out of the joint.

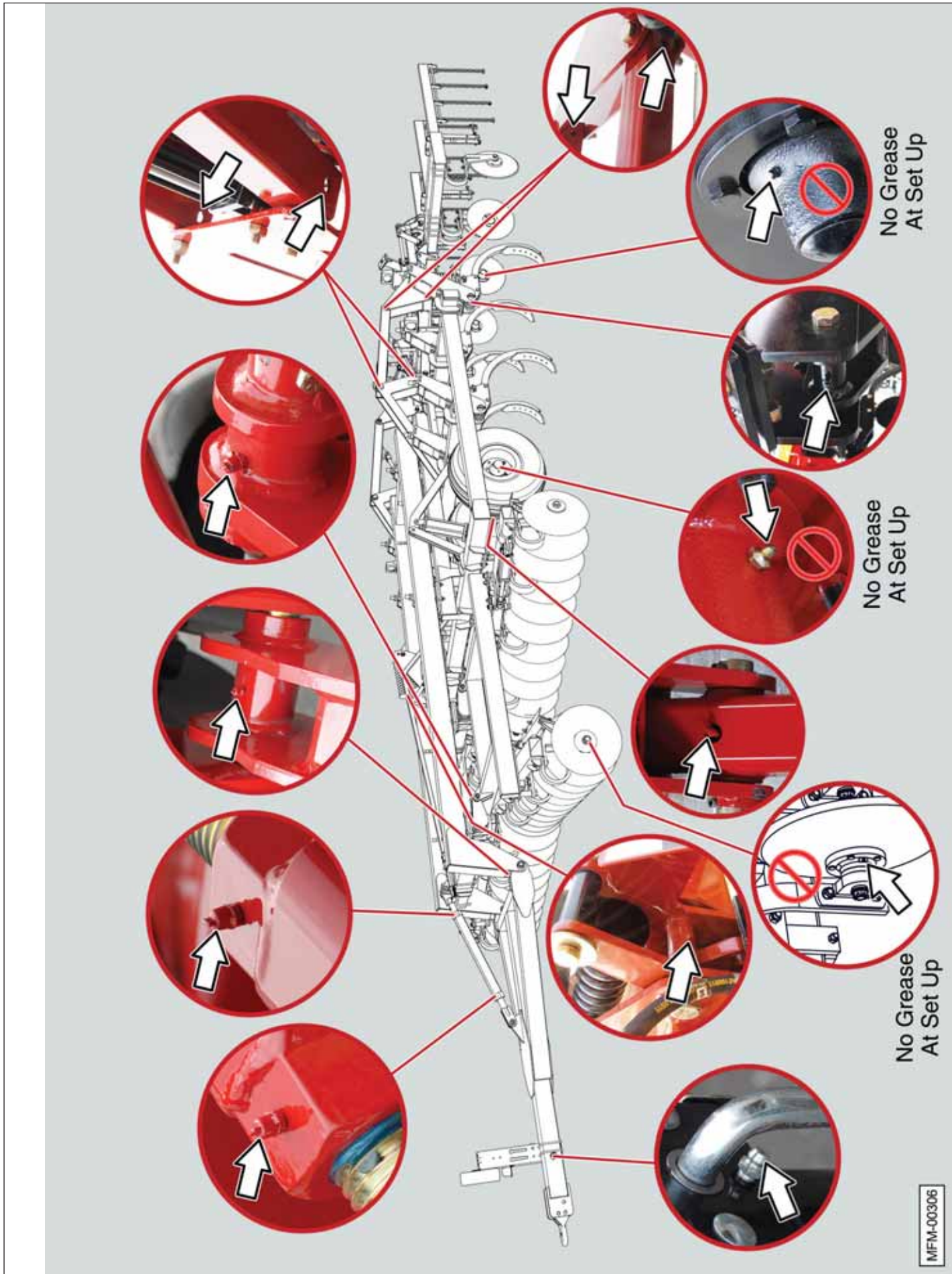

Hydraulic Components

Safety

WARNING



Trapped Air Hazard

When installing, replacing, or repairing hydraulic system cylinders or parts, make sure that the entire system is charged and free of air before resuming operations. Failure to bleed the system of all air can result in improper machine operation, causing severe injury.



Zero Pressure

Relieve pressure from the hydraulic system before servicing or disconnecting from the tractor.



High-Pressure Fluid Hazard

Keep all hydraulic lines, fittings, and couplers tightly secured and free of leaks.



Explosive Separation Hazard

Replace any worn, cut, abraded, flattened, or crimped hoses.



High-Pressure Hazard

Do not make any temporary repairs to the hydraulic lines, fittings, or hoses using tape, clamps, or cement. The hydraulic system operates under extremely high pressure and temporary repairs may fail suddenly and create a hazardous/dangerous situation.



Personal Protection Equipment

Wear proper hand and eye

protection when searching for a high-pressure hydraulic leak. Use a piece of wood or cardboard as a backstop instead of hands to identify and isolate a leak. If injured by a concentrated high-pressure stream of hydraulic fluid, seek medical attention immediately. Serious infection or toxic reaction can develop if hydraulic fluid penetrates the surface of the skin.



High-Pressure Fluid Hazard

Before applying pressure to the system, make sure all components are tight and that the hydraulic lines, hoses, and couplings are not damaged.

NOTICE

Make sure components in the hydraulic system are kept clean and in good working condition.

Wheel Lift Cylinders, Disk Gang, and Leveler Disk Wing Cylinders

There are no setup procedures or maintenance items on these cylinders.

Rear Disk Leveler Cylinders

The rear disk leveler cylinders use a rephasing or sequencing circuit. This type of hydraulic circuit allows both cylinders to raise and lower simultaneously.

If the cylinders do not extend and retract together, use the following procedure to put them back in phase with one another.

1. Raise the leveler disk unit completely and hold the control valve lever in the raise position for approximately 20 seconds.
2. Lower the leveler disks.
3. Repeat Step 1 and Step 2 until both cylinders raise and lower at the same time.

Tire Safety

WARNING



Explosive Separation Hazard

Do not attempt to mount tires unless you have the proper equipment and experience to do the job. Failure to follow proper procedures when mounting a tire on a wheel or rim can produce an explosive separation, which may result in serious injury or death.



Explosive Hazard

Never weld or heat a wheel and tire assembly. The heat can cause an increase in air pressure, resulting in a tire explosion. Welding can structurally weaken or deform the wheel.



Flying Objects Hazard

Inflating or servicing tires can be dangerous. Whenever possible, trained personnel should be called to service and/or mount tires.

When inflating tires, use a clip-on chuck and extension hose. Always stand to the side of the tire when inflating, and NOT in front of or over the tire assembly.

Make sure the tires are inflated evenly.



Crush Hazard

Make sure the unit is completely supported with suitable stands before removing a wheel assembly.

SAFETY INSTRUCTIONS



Always maintain the correct tire pressure. Do not inflate the tires above the recommended pressure.



Check tires for low pressure, cuts, bubbles, damaged rims, or missing lug bolts and nuts.



Always install tires and wheels with appropriate capacity to meet or exceed the weight of the unit.



Do not exceed 20 mph or tire failure will occur.



Keep wheel lug nuts or bolts tightened.

Disk Gang Disks

1. Replace the disk blades when the diameter is 22 inches or less.
2. It will also be necessary to check and tighten the disk gang arbor bolts to prevent excessive wear.

Tighten the gang arbor bolts to 600 to 800 ft-lb.

Note: A torque of 600 ft-lb would be equivalent to using a 4 foot wrench with a 150 pound person hanging freely on the end.

A torque of 800 ft-lb would be equivalent to a 200 pound person using a 4 foot wrench.

Front Disk Gang Coil Spring System

WARNING



Spring Tension Hazard

Compressed springs can contain enough energy to cause serious bodily injury and even death. Do not remove retainer (3) until all spring tension is released. Use extreme caution when working around broken springs that are compressed.

1. Place blocks under the disk gang frame or disk gangs to support the unit. This will remove the pressure from the spring assembly, allowing it to be removed.

2. Attach a lifting device to the spring assembly. Make sure there is no tension on the bolt and remove lock nut (2) from bolt (1) and remove bolt. Then remove cotter pin (4) from clevis pin (3) and remove the pin.

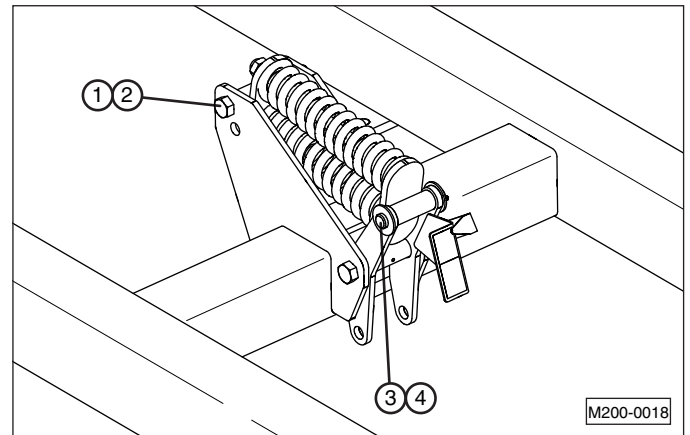

3. Remove the spring assembly.
4. Remove two lock nuts (5) from spring retainer shaft (9). Slowly remove two retainer nuts (6) to release the spring tension. Alternately turn the nuts to evenly release the spring pressure.

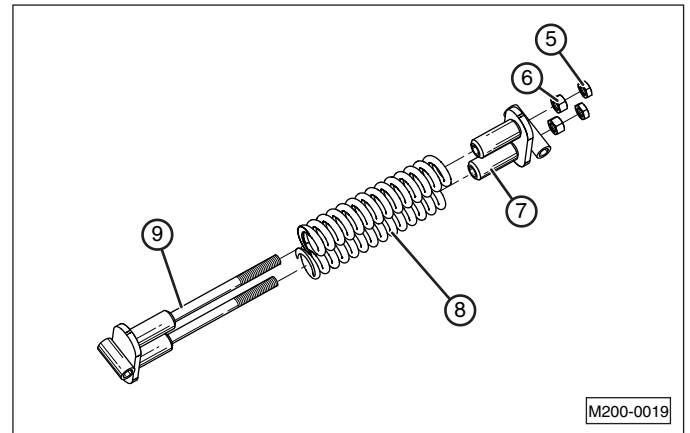

Note: Retainer nuts (6) can be removed using the wrench supplied/attached to the frame of the unit.

5. Remove retainer (7) and springs (8). If necessary, replace spring mount (9).
6. Reassemble all parts.
7. Tighten retainer nuts (6) until the springs are compressed to 15.0" (38.1 cm). Install and tighten locknuts (5).
8. Reinstall the spring assembly.

Chisel Shank Spring Replacement

WARNING



Spring Tension Hazard
Compressed springs can contain enough energy to cause serious bodily injury and even death. Do not remove the chisel shank retainer bracket until all spring tension is released. Use extreme caution when working around broken springs that are compressed.

1. If necessary, remove the chisel shank. The chisel shank assembly and shovel weigh approximately 165 lbs. Refer to the Assembly Manual for additional information on removal and installation procedures.
2. Loosen the set screw and remove lock nut (2) from spring retainer shaft (1). Slowly remove retainer nut (3) and release the spring tension.

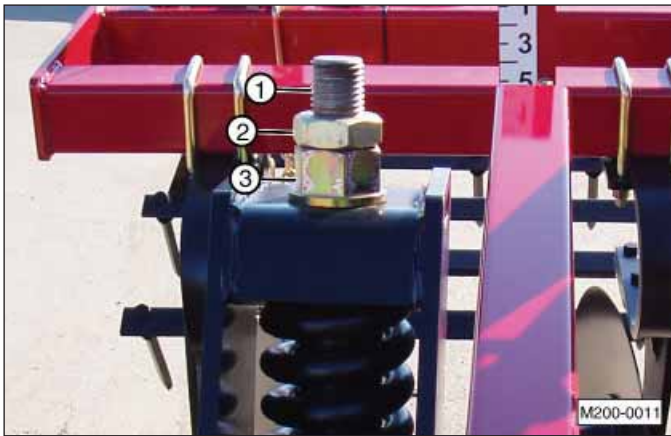

Note: Retainer nut (3) can be removed using the wrench supplied/attached to the frame of the unit.

3. Remove bolt (4), lock nut (5), and pivot pin (6). Replace the worn or broken parts.



4. Install and tighten removed bolts. Do not overtighten bolt (4).

5. Tighten retainer nut (3) until the spring is compressed to 14.0" (35.56 cm). Install locknut (2) and tighten the setscrew.



Chisel Shank Point/Shovel Replacement

The chisel points/shovels (2) are reversible. When the point becomes less effective, reverse or replace the shovel.

1. Remove plow bolts (3), square washers (5), and locknuts (4) from shank (1).

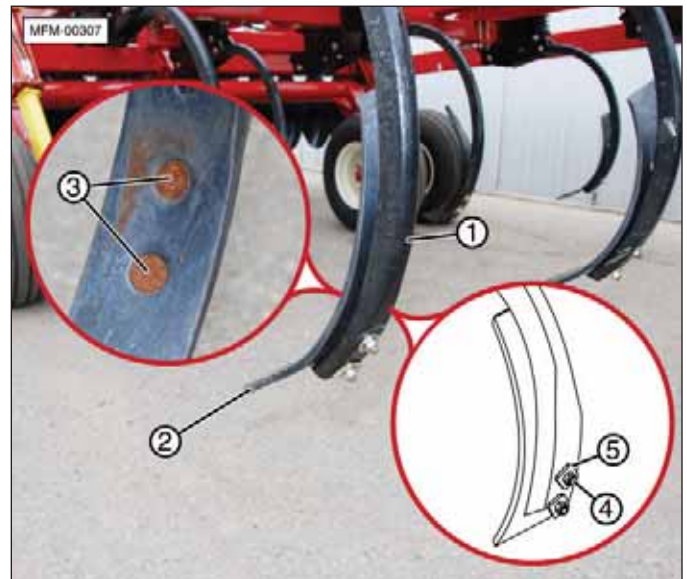

2. Install the twisted shovels with plow bolts (3), square washers (5) and lock nuts (4).

Note: A straight point, a three inch twisted shovel, or a four inch twisted shovel are interchangeable on the chisel shank.

Troubleshooting

| Problem | Cause | Solution |
|---------------------------------------------------------------------------------------------|-----------------------------------------------------------------------------------------------------------------------------------------|---------------------------------------------------------------------------------------------------------------------------------------------------------------------------------------------------------------------------|
| Disk gang is not tilling to desired depth or the soil is not fully worked to desired depth. | Disk gang is not set deep enough. | Increase the depth of the disk gang up to a 4 inch maximum depth. Whenever you are making a change to any setting, make sure the unit remains level as it is pulled through the field. |
| | Disk gang angle is not set properly for the soil conditions. | Increase disk gang angle to loosen more soil. |
| The ground is not level behind the leveler disk and harrow. | The rear leveler disks are set too shallow or too deep into the ground. | Raise the leveler disk until the ground levels out. When set too deep, the disks cut furrows in the ground that the harrow cannot level out. |
| The residue is not being turned into the ground. | The front gang disk is not set at an aggressive enough angle. | Increase the angle of the front disk gang. |
| | The front gang disk is not set deeply enough. | Increase the depth of the disk gang up to a 4 inch maximum depth. Whenever you are making a change to any setting, make sure the unit remains level as it is pulled through the field. |
| The residue is not being sized correctly. | The front disk gang may not be set deep enough. | Increase the depth of the disk gang up to a 4 inch maximum depth. Whenever you are making a change to any setting, make sure the unit remains level as it is pulled through the field. |
| The disk gang indicator is pointing to the black area. | Too much force is being placed on the disk gangs or the soil conditions are too hard for the depth or the angle the disk gangs are set. | Raise the disk gang. |
| | | Set the angle of the disk to be less aggressive. |
| | | Reduce the speed. A speed of 5 to 6-1/2 miles per hour is recommended. |
| Ridging is occurring. | Front disk gang is not set correctly. | Raise the disk gang. |
| | | Set the angle of the disk to be less aggressive. |
| | | Reduce the speed. A speed of 5 to 6-1/2 miles per hour is recommended. |
| Residue buildup on harrow bars. | Front disk gang is not set correctly. | Set the disk gang to a more aggressive angle in order to size the residue into smaller pieces. |
| | The harrow angle is not set correctly. | Change the angle of the teeth. Using the linkage settings that produce the flattest angle on the harrow is recommended. Setting the harrow to the steepest angle is usually recommended for spring work or light residue. |

Storage

Safety

SAFETY INSTRUCTIONS

Follow all operating and safety instructions found in this manual when storing this equipment.



Store the unit in an area away from human activity.



Do not permit children to play on or around the stored unit at any time.

Make sure the unit is stored in an area with a firm and level base to prevent it from tipping or sinking into the ground.



Block the wheels to prevent the unit from rolling.

Placing Into Storage (Disk Coatings)

Apply a thin layer of grease to all exposed metal surfaces of the disks, points, and shanks.

Disposal of Equipment at End of Useful Life

The McFarlane Quadra-Till has been designed for the specific purpose of tilling agricultural farm land. When this unit is no longer capable of doing its designed purpose, it should be dismantled and scrapped. Do not use any materials or components from this unit for any other purpose.

Parts Section

Ordering Parts

We manufacture a quality product that requires very little maintenance or repair. However, should a part break or become damaged, our knowledgeable staff can make sure you receive the part(s) to put your unit back into operation.

Dealer Contact Information

For replacement decals, questions, or to order parts, contact your dealer:



Decals

WARNING



Make sure all decals are attached to the unit and are legible at all times. Safety decals and reflective tape provide a vital role in helping to reduce injuries and/or possibly even death.

To ensure the greatest level of safety, all decals must be in place and legible at all times. Remember, it is the users' responsibility to maintain these decals.

Parts Drawings

Hitch Frame Assembly

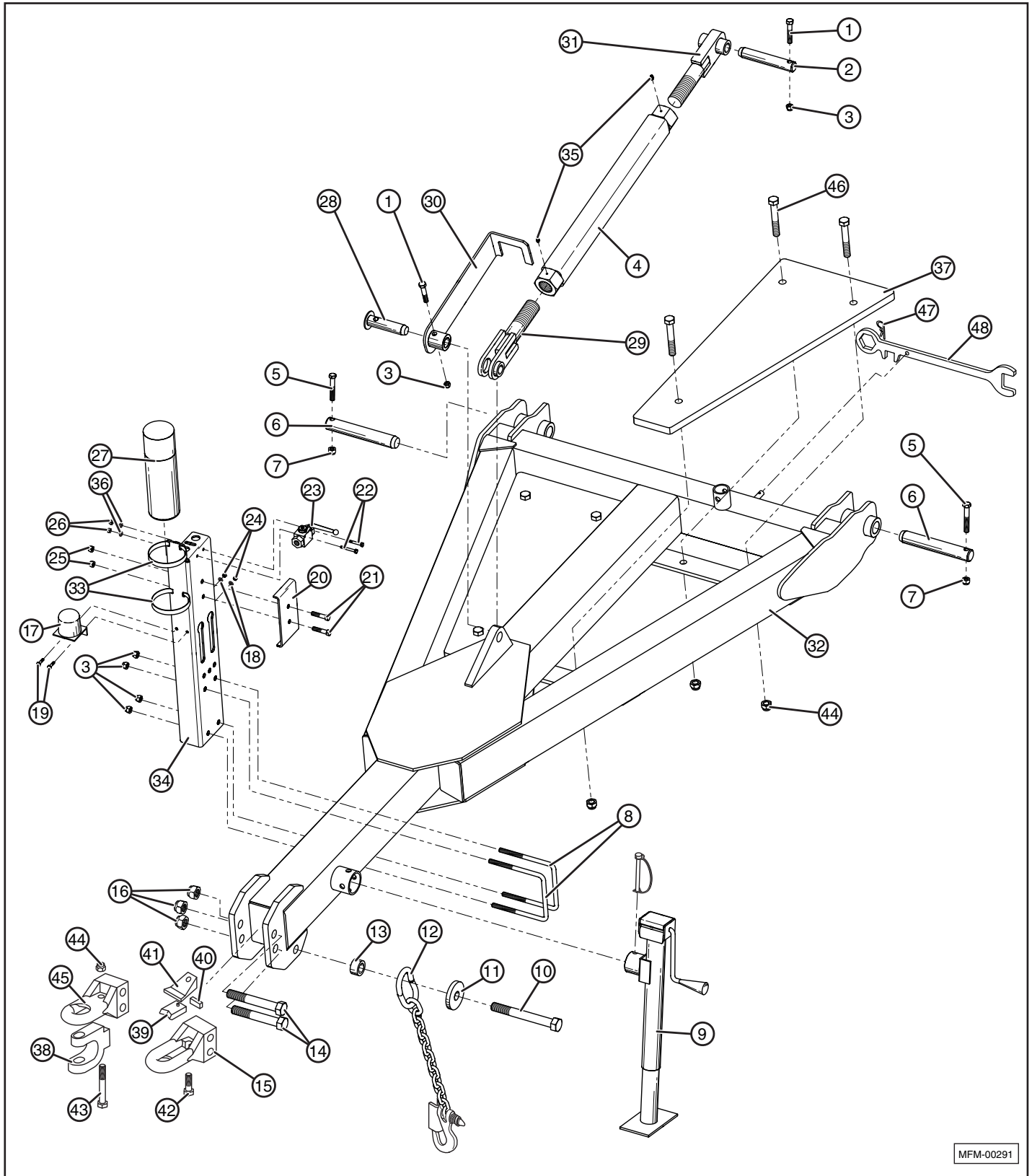

MFM-00291

| Item | Part Number | Description | Qty. |
|------|-------------------------------|-----------------------------------------------------------------------------------------------------------------------------|------|
| 1 | BH-5028 | SCREW, CAP, HEX, 1/2-13 x 2-3/4", GRADE 5 | 2 |
| 2 | RT-2124 | LEVEL LIFT TUBE PIN | 1 |
| 3 | NLT-5013 | NUT, LOCK, HEX, 1/2-13 | 6 |
| 4 | RT-3145 | TURNBUCKLE TUBE ASSY | 1 |
| 5 | BHY-5635 | SCREW, CAP, HEX, 9/16-12 x 3-1/2, GRADE 8 | 2 |
| 6 | RT-2107 | LINKAGE PIN | 2 |
| 7 | NLT-5612 | NUT, LOCK, HEX, 9/16-12 | 2 |
| 8 | BU-1267 | U-BOLT, 1/2 x 6 x 7-1/4" | 2 |
| 9 | QT-1243 | JACK, 15" SQ., 8,000 LB | 1 |
| 10 | BHY-1085 | SCREW, CAP, HEX, 1-8 x 8-1/2", GRADE 8 | 1 |
| 11 | RT-3103 | SAFETY CHAIN WASHER | 1 |
| 12 | CH-1816 CH-1820 CH-1830 | SAFETY CHAIN, 16,100 LBS (7, 9 SHANK) SAFETY CHAIN, 20,200 LBS (11 SHANK) SAFETY CHAIN, 30,400 LBS (13, 15, 17 SHANK) | 1 |
| 13 | RT-2054 | SAFETY CHAIN BUSHING | 1 |
| 14 | BHY-1070 | SCREW, CAP, HEX, 1-8 x 7", GRADE 8 | 2 |
| 15 | PPI-300 | HITCH BASE (7 SHANK ONLY) | 1 |
| 16 | NLT-1008 | NUT, LOCK, HEX, 1-8 | 3 |
| 17 | LB-1110 | BRACKET, LIGHT PLUG | 1 |
| 18 | LW-0025 | WASHER, LOCK, 1/4 | 2 |
| 19 | BH-2510 | SCREW, CAP, HEX, 1/4-20 x 1, GRADE 5 | 2 |
| 20 | RD-4309 | HYDRAULIC HOSE RACK CLAMP | 1 |
| 21 | BH-4420 | SCREW, CAP, HEX, 7/16-14 x 2, GRADE 5 | 2 |
| 22 | BH-2520 | SCREW, CAP, HEX, 1/4-20 x 2, GRADE 5 | 2 |
| 23 | QT-1172 | VALVE, BALL, 3/4" | 1 |
| 24 | NH-2520 | NUT, HEX, 1/4-20 | 10 |
| 25 | NLT-4414 | NUT, LOCK, HEX, 7/16-14 | 2 |
| 26 | NH-2520 | NUT, HEX, 1/4-20 | 2 |
| 27 | RD-4306 | DOCUMENT TUBE | 1 |
| 28 | RT-2113 | HITCH TURNBUCKLE PIN | 1 |

| Item | Part Number | Description | Qty. |
|------|---------------------------------------------|----------------------------------------------------------------------------------------------------------------------------------------------------------------------------------------------------------------------------------|-------------------------------|
| 29 | RT-2111 | TURNBUCKLE HITCH END | 1 |
| 30 | RT-2114 | HITCH TURNBUCKLE LOCK | 1 |
| 31 | RT-2112 | TURNBUCKLE PIVOT END | 1 |
| 32 | QT-1244 QT-1228 | HITCH FRAME (7, 9, 11 SHANK) HITCH FRAME (13, 15, 17 SHANK) | 1 |
| 33 | MM-1204 | CLAMP, HOSE, 3.8125" | 2 |
| 34 | 10294 | BRACKET, STORAGE, HITCH | 1 |
| 35 | GZ-2528 | ZERK, GREASE | 2 |
| 36 | LW-0025 | WASHER, LOCK, 1/4 | 2 |
| 37 | 10772 | WEIGHT, 108 LB. (207-IRB, 207-RB) WEIGHT, 108 LB. (209-IRB, 209-RB) WEIGHT, 108 LB. (211-IRB, 211-RB) WEIGHT, 108 LB. (213F-IRB, 213F-RB) WEIGHT, 108 LB. (215F-IRB, 215F-RB) WEIGHT, 108 LB. (217F-IRB, 217F-RB) | 4 6 6 14 12 12 |
| 38 | PPI-208 | HITCH CLEVIS | 1 |
| 39 | PPI-203 | V -PLATE | 1 |
| 40 | PPI-201 | CUSHION | 1 |
| 41 | PPI-302 | TOP PLATE | 1 |
| 42 | BHY-7525 | BOLT, 3/4 - 10 x 2-1/2 GD 8 | 1 |
| 43 | BHY-7555 | BOLT, 3/4 - 10 x 5-1/2 GD 8 | 1 |
| 44 | NLT-7510 | NUT, TOP LOCK, 3/4 - 10 | 1 |
| 45 | PPI-400 | HITCH BASE (9, 11, 13, 15, 17 SHANK) | 1 |
| 46 | BHY-7535 BH-7545 BHY-7590 BHY-7580 | BOLT, 3/4 - 10 x 3-1/2" (QT-207) BOLT, 3/4 - 10 x 4-1/2" (QT-209, QT-211) BOLT, 3/4 - 10 x 9" (QT-213F) BOLT, 3/4 - 10 x 8" (QT-215F, QT-217F) | 6 |
| 47 | PB-0009 | PIN, BRIDGE, #9 | 1 |
| 48 | 10273 | WRENCH, TURNBUCKLE | 1 |

Main Frame Assembly

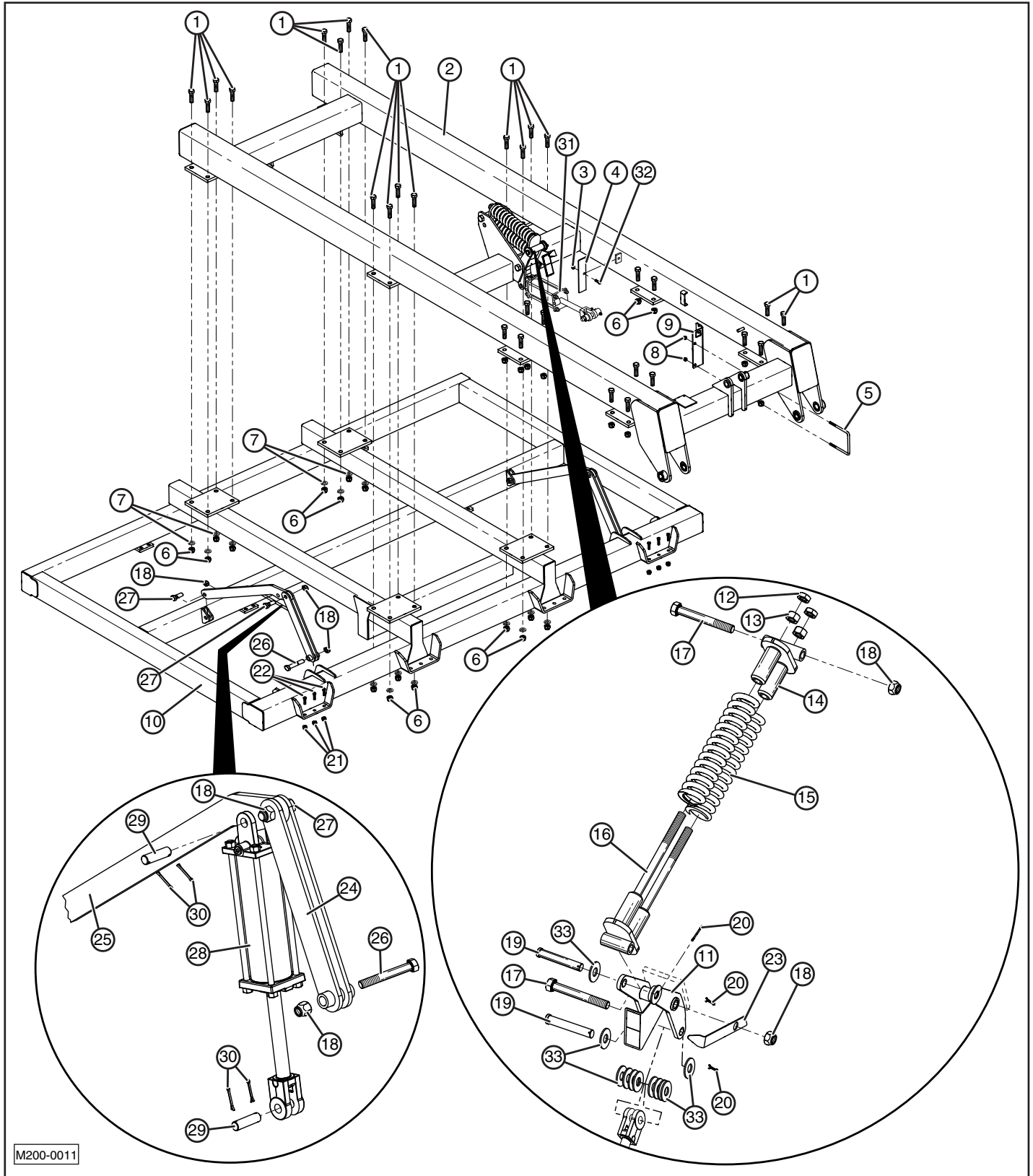

M200-0011

| Item | Part Number | Description | Qty. |
|------|------------------------------------------|----------------------------------------------------------------------------------------------------------------|------|
| 1 | BH-8830 | BOLT, HEX, 7/8-9 x 3 GD 5 | 32 |
| 2 | 10904 10905 10773 10660 | MAIN FRAME (QT-207 - QT211) MAIN FRAME (QT-213) MAIN FRAME (QT-213F) MAIN FRAME (QT-215F and QT-217F) | 1 |
| 3 | NLT-3816 | NUT, TOP LOCK, 3/8-16 | 6 |
| 4 | QT-1245 | DISK DEPTH GAUGE | 1 |
| 5 | BU-1267 | U-BOLT, 1/2 X 6 x 7 | 1 |
| 6 | NH-8809 | NUT, HEX, 7/8-9 | 32 |
| 7 | LW-0088 | WASHER, LOCK, 7/8 | 32 |
| 8 | NLT-5013 | NUT, TOP LOCK, 1/2-13 | 2 |
| 9 | QT-1140 | HYD STOP FRAME BRACKET | 1 |
| 10 | QT-1193 QT-1194 QT-1195 QT-1196 | CHISEL FRAME ASSY 7 CHISEL FRAME ASSY 9 CHISEL FRAME ASSY 11 CHISEL FRAME ASSY 13/13F | 1 |
| 11 | QT-1118 QT-1266 | DISK SPRING BRACKET ASSY DISK SPRING BRACKET, 215F, 217F | 1 |
| 12 | NHJ-1008 NHJ-1506 | NUT, JAM 1-8 NUT, JAM 1 1/2 - 6, 215F, 217F | 2 |
| 13 | NH-1008 NH-1506 | NUT 1-8 NUT 1 1/2 - 6, 215F, 217F | 2 |
| 14 | QT-1121 QT-1269 | SPRING SYSTEM ADJUSTMENT ASSY SPRING SYSTEM ADJUSTMENT ASSY, 215F, 217F | 1 |
| 15 | QT-1001 QT-1182 | SPRING SPRING, 4.375 x 17, 215F, 217F | 2 |
| 16 | QT-1120 QT-1268 | SPRING SYSTEM MOUNT ASSY SPRING SYSTEM MOUNT, 215F, 217F | 1 |
| 17 | BHY-1080 | BOLT, 1-8 x 8 GD 8 | 2 |
| 18 | NLT-1008 | NUT, TOP LOCK 1-8 | 8 |
| 19 | CL-1006 | CLEVIS PIN 1 x 6 | 2 |
| 20 | CP-3620 | COTTER, 3/16 x 2 | 2 |
| 21 | NLT-6311 | NUT, TOP LOCK 5/8-11 | 12 |
| 22 | BH-6320 | BOLT, 5/8-11 x 2 GD 5 | 12 |
| 23 | QT-1119 | SPRING SYSTEM GAUGE INDICATOR | 1 |
| 24 | QT-1201 | AXLE TRUSS ASSY | 2 |
| 25 | QT-1202 QT-1271 | AXLE CYL ARM AXLE CYL ARM, 215F, 217F | 2 |
| 26 | BHY-1065 | BOLT, 1-8 x 6-1/2 GD 8 | 2 |
| 27 | BHY-1033 | BOLT, 1-8 x 3-1/4 GD 8 | 4 |
| 28 | HYC-34012 | HYDRAULIC CYLINDER, 4 x 12 | 2 |
| 29 | HYO-2103 | CYLINDER CLEVIS PIN, 1 x 3 | 2 |
| 30 | CP-3620 | 3/16 x 2 COTTER PIN | 4 |
| 31 | HYA-34008 | HYDRAULIC CYLINDER | 1 |
| 32 | BH-3810 | BOLT, HEX 3/8-16 x 1 GD 5 | 1 |
| 33 | FW-0100 | FLAT WASHER, 1" | 12 |

QT-215F and QT-217F Chisel Frame

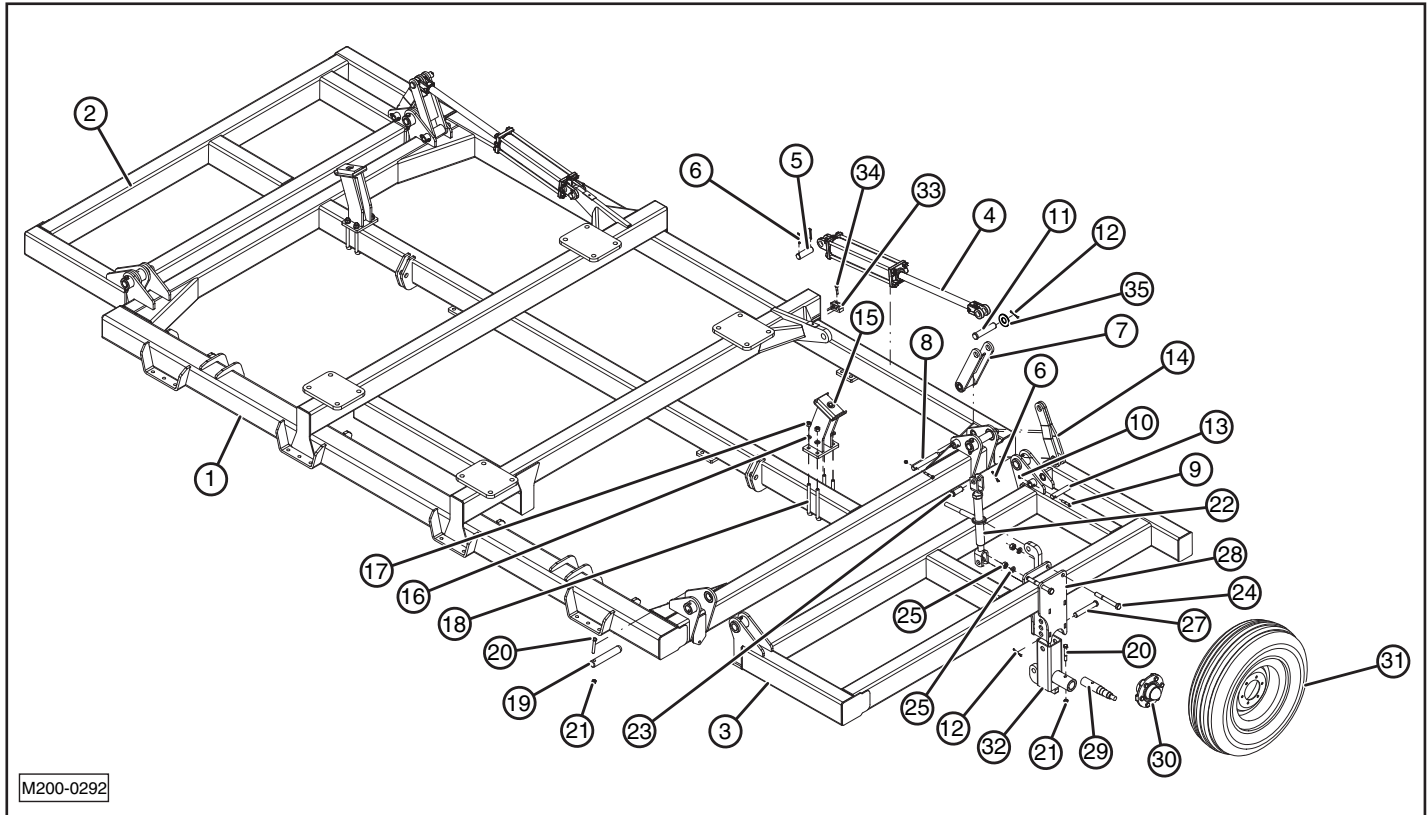

M200-0292

| Item | Part Number | Description | Qty. |
|------|--------------------|--------------------------------------------------------------------|------|
| 1 | QT-1249 | CF ASSY CENTER 215F, 217F | 1 |
| 2 | QT-1251 QT-1253 | CHISEL FRAME, WING, RT, QT-215F CHISEL FRAME, WING, RT, QT-217F | 1 |
| 3 | QT-1250 QT-1252 | CHISEL FRAME, WING, LT, QT-215F CHISEL FRAME, WING, LT, QT-217F | 1 |
| 4 | HYA-33516 | CYLINDER 3-1/2 x 16 | 2 |
| 5 | HYO-2103 | CYLINDER PIN 1 x 3-1/2 | 2 |
| 6 | CP-3620 | COTTER PIN 3/16 x 2 | 8 |
| 7 | QT-1263 | CHISEL CENTER LINKAGE ASSY | 2 |
| 8 | QT-1276 | CHISEL CENTER LINKAGE PIN | 2 |
| 9 | BH-3823 | BOLT 3/8-16 x 2-1/4 | 4 |
| 10 | NLT-3816 | NUT TOP LOCK 3/8-16 | 4 |
| 11 | CL-1305 | CLEVIS PIN 1-1/4 x 5 | 2 |
| 12 | CP-1820 | COTTER PIN 1/8 x 2 | 4 |
| 13 | QT-1057 | DF HITCH PIN | 2 |
| 14 | QT-1264 | CHISEL WING LINKAGE ASSY | 2 |
| 15 | QT-1265 | CHISEL WING REST ASSY | 2 |
| 16 | LW-0063 | LOCK WASHER 5/8 | 8 |
| 17 | NH-6311 | HEX NUT 5/8-11 | 8 |
| 18 | BU-5848 | U-BOLT 5/8 x 4 x 8 | 4 |
| 19 | SPR-2712 | HINGE PIN 8 | 4 |

| Item | Part Number | Description | Qty. |
|------|-------------|---------------------------|------|
| 20 | BH-5635 | BOLT 9/16-12 x 3-1/2 | 4 |
| 21 | NLT-5612 | NUT TOP LOCK 9/16-12 | 4 |
| 22 | HYO-2008 | RATCHET, 8" | 2 |
| 23 | HD-1149 | CLEVIS PIN 1 x 2-1/2 | 4 |
| 24 | BH-7565 | BOLT 3/4-10 x 6-1/2 | 4 |
| 25 | LW-0075 | LOCK WASHER 3/4 | 4 |
| 26 | NH-7510 | NUT 3/4-10 | 4 |
| 27 | CL-1006 | CLEVIS PIN 1 x 6 | 2 |
| 28 | QT-1278 | GAUGE WHEEL MOUNT ASSY | 2 |
| 29 | WDL-2505 | SPINDLE | 2 |
| 30 | HD-1371 | HUB ASSY 6 HOLE | 2 |
| 31 | 9.5L-15 8TR | TIRE/WHEEL 6 HOLE | 2 |
| 32 | QT-1280 | GAUGE WHEEL VERTICAL ASSY | 2 |
| 33 | HYO-1201 | HOSE CLAMP SET | 2 |
| 34 | BH-3118 | BOLT 5/16 x 1-3/4 | 2 |
| 35 | FW-0125 | FLAT WASHER, 1-1/4" | 2 |

Disk Gang Frame Assembly (QT-207 - QT-213F)

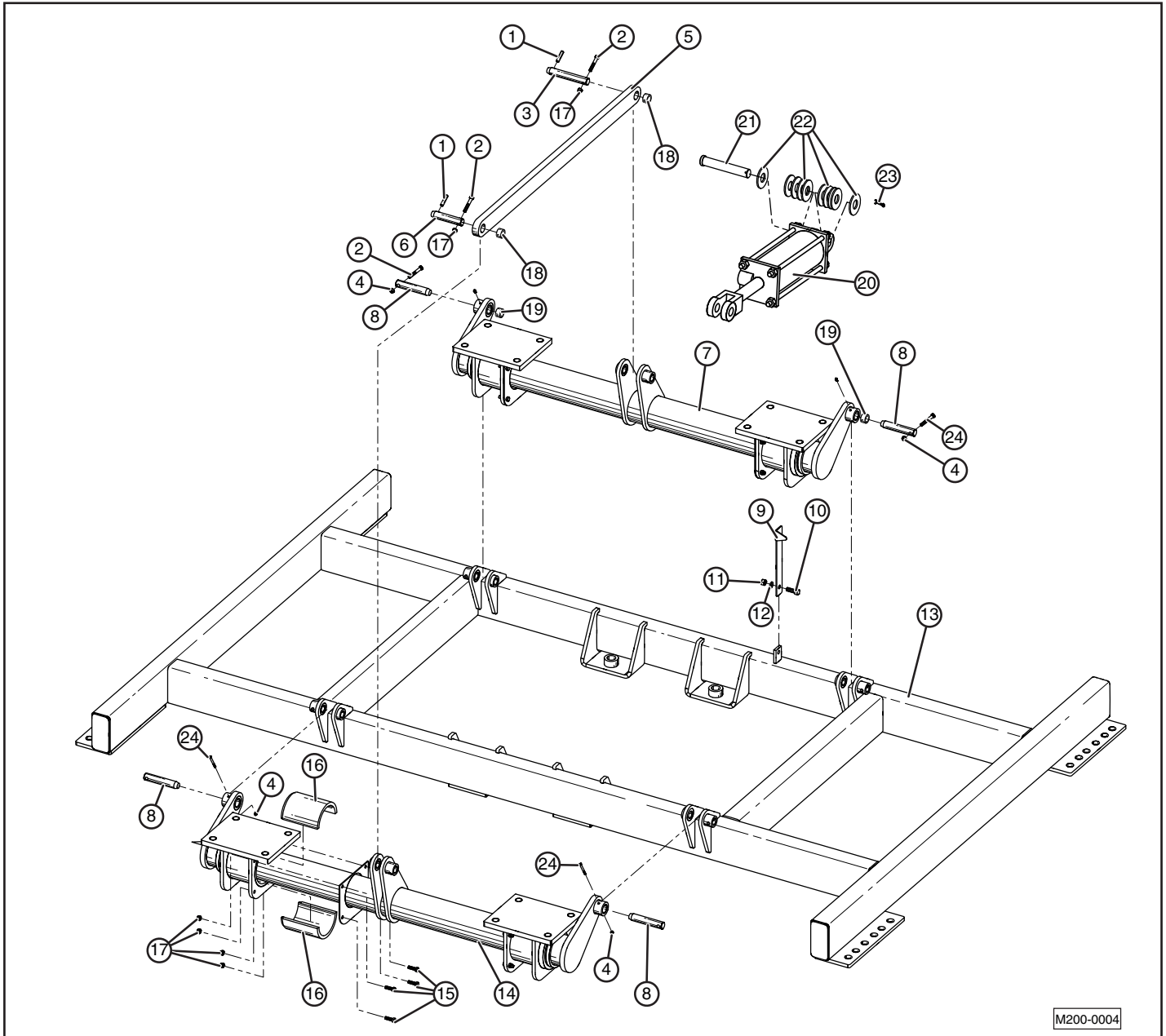

| Item | Part Number | Description | Qty. |
|------|-------------|--------------------------------|------|
| 1 | QT-1149 | PIN, SPRING ROLL, 7/16 x 1-3/4 | 2 |
| 2 | BH-3823 | BOLT, 3/8-16 x 2-1/4 GD 5 | 2 |
| 3 | QT-1148 | DISK HITCH PIVOT PIN REAR | 1 |
| 4 | NLT-5013 | NUT, TOP LOCK, 1/2-13 | 6 |
| 5 | QT-1017 | DISK HITCH LINKAGE | 1 |
| 6 | QT-1125 | DISK HITCH PIVOT PIN FRONT | 1 |
| 7 | QT-1274 | DISK HITCH PIVOT REAR ASSEMBLY | 1 |
| 8 | QT-1277 | DISK FRAME HITCH PIN | 4 |
| 9 | QT-1048 | DISK DEPTH INDICATOR | 1 |
| 10 | BH-5013 | BOLT, 1/2-13 X 1-1/4 | 1 |
| 11 | NH-5013 | NUT, 1/2-13 | 1 |
| 12 | LW-0050 | LOCK WASHER, 1/2 | 1 |

| Item | Part Number | Description | Qty. |
|------|-------------------------|-------------------------------------------------------------------------------|------|
| 13 | 11103 11104 11105 | DISK FRAME, 7 & 9 SHANK DISK FRAME, 11 & 13 SHANK DISK FRAME, 13F SHANK | 1 |
| 14 | QT-1273 | DISK HITCH PIVOT ASSY | 1 |
| 15 | BH-3813 | BOLT, 3/8-16 X 1-1/4 | 8 |
| 16 | QT-1129 | DISK HITCH MOUNT INSERT | 2 |
| 17 | NLT-3816 | NUT, TOP LOCK, 3/8-16 | 8 |
| 18 | QT-1150 | SPLIT BUSHING, 1.25 X 1 - 1 | 2 |
| 19 | QT-1179 | SPLIT BUSHING, 1.5 X 1.25 - 1 | 8 |
| 20 | HYA-34008 | HYDRAULIC CYLINDER | 1 |
| 21 | CL-1006 | CLEVIS PIN, 1 x 6 | 1 |
| 22 | FW-0100 | FLAT WASHER, 1" | 10 |
| 23 | CP-3620 | COTTER PIN, 3/16 x 2 | 1 |
| 24 | BH-5028 | BOLT, 1/2-13 x 2 3/4 GD 5 | 4 |

QT-215F and QT-217F Disk Frame

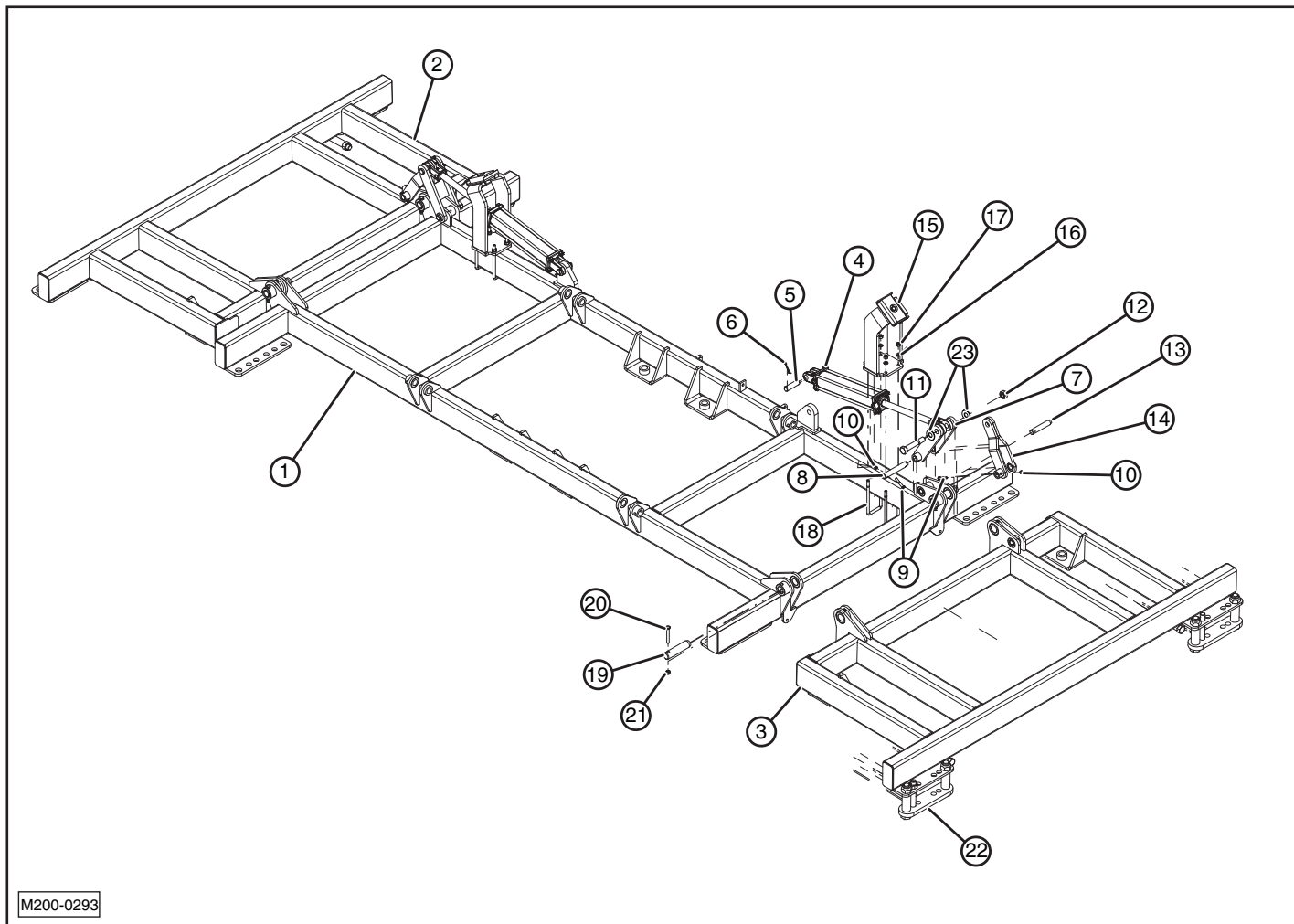

| Item | Part Number | Description | Qty. |
|------|-------------|------------------------------------|------|
| 1 | 11173 | QT-215F and QT-217F DISK FRAME | 1 |
| 2 | 10589 | RH WING DISK FRAME | 1 |
| 3 | 10588 | LH WING DISK FRAME | 1 |
| 4 | HYC-34014 | CYLINDER 4 x 14 | 2 |
| 5 | HYO-2103 | CYLINDER PIN 1 x 3-1/2 | 2 |
| 6 | CP-3620 | COTTER PIN 3/16 x 2 | 4 |
| 7 | QT-1211 | DISK CENTER LINKAGE ASSY | 2 |
| 8 | QT-1148 | DISK HITCH PIVOT PIN REAR | 2 |
| 9 | BH-3823 | BOLT 3/8-16 x 2-1/4 | 4 |
| 10 | NLT-3816 | NUT TOP LOCK 3/8-16 | 4 |
| 11 | 10673 | BOLT, 1 x 7, GRADE 8 LONG SHOULDER | 2 |
| 12 | NLT -1008 | NUT, TOP LOCK, 1 - 8 | 2 |

| Item | Part Number | Description | Qty. |
|------|-------------|-----------------------------|------|
| 13 | QT-1057 | DF HITCH PIN | 2 |
| 14 | QT-1212 | DISK WING LINKAGE ASSY | 2 |
| 15 | QT-1267 | DISK WING REST ASSY | 2 |
| 16 | LW-0050 | LOCK WASHER 1/2 | 8 |
| 17 | NH-5013 | HEX NUT 1/2-13 | 8 |
| 18 | BU-1237 | U-BOLT 1/2 x 3 x 7 | 4 |
| 19 | WD-2915 | CONNECTOR PIN | 4 |
| 20 | BH-5635 | BOLT 9/16-12 x 3-1/2 | 4 |
| 21 | NLT-5612 | NUT TOP LOCK 9/16-12 | 4 |
| 22 | QT-1272 | DISK ADJUST CLAMP WING ASSY | 4 |
| 23 | FW-0100 | WASHER, FLAT, 1" | 4 |

Disk Gang Mounting Hardware

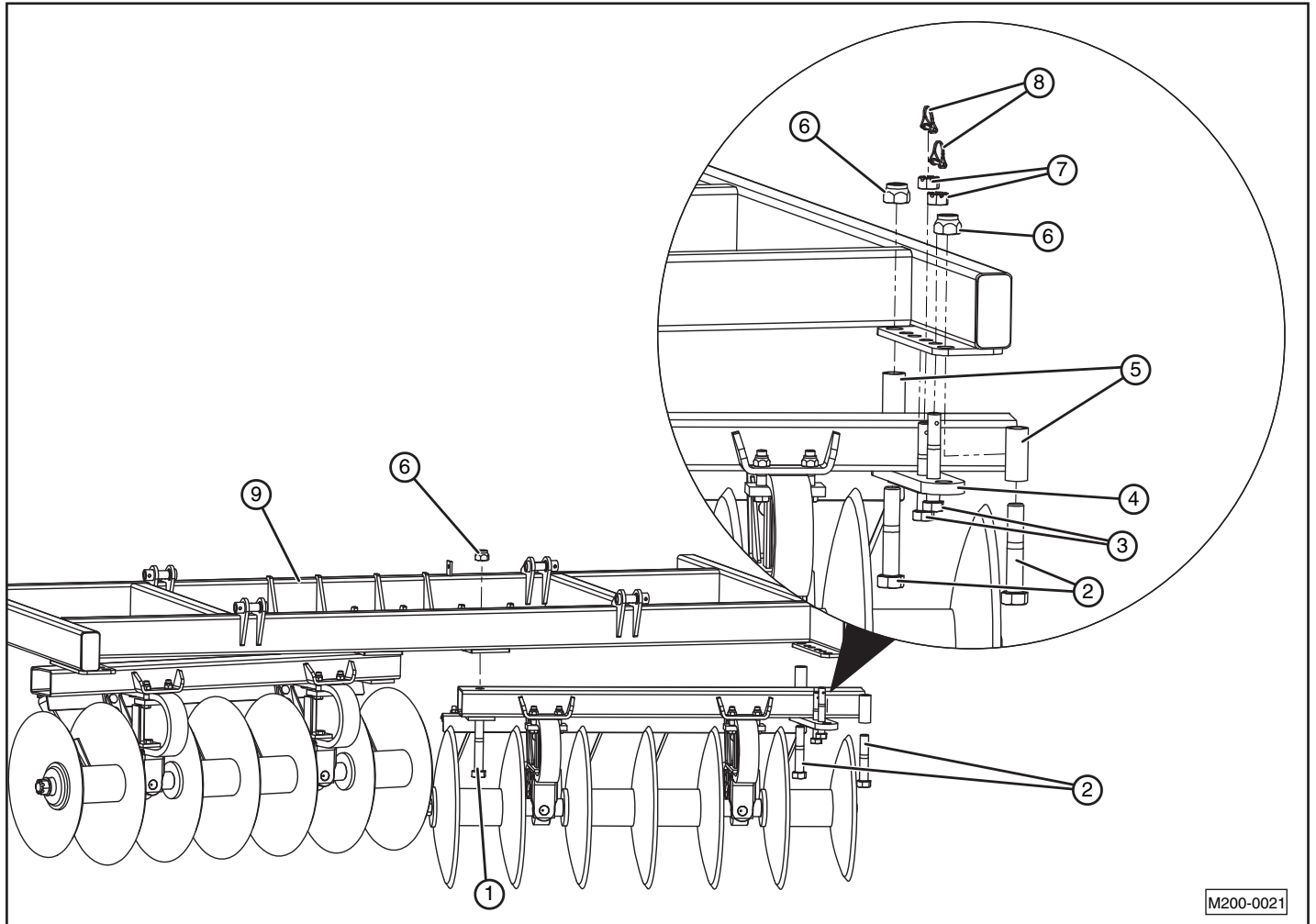

M200-0021

| Item | Part Number | Description | Qty. |
|------|-------------------------|-------------------------------------------------------------|------|
| 1 | BHY-1380 | BOLT, HEX, 1-1/4-7 x 8, GD 8 | 1 |
| 2 | 10707 | BOLT, HEX, 1-1/4-7 x 7-1/4, GD 8 | 2 |
| 3 | RD-4431 | BOLT, W/ CROSS HOLE 1-8 x 7 GD 8 | 2 |
| 4 | QT-1186 | CLAMP ASSY, DISK ADJUST | 1 |
| 5 | QT-1209 | BUSHING, DISK ADJUST PIVOT STOP | 2 |
| 6 | NY-1307 | NUT, NYLON LOCK 1-1/4 - 7 | 3 |
| 7 | NC-1008 | NUT, CASTLE 1-8 | 2 |
| 8 | PC-1913 | PIN, CLICK, 3/8 x 1.56 | 2 |
| 9 | 11103 11104 11105 | DISK FRAME, 7 & 9 DISK FRAME, 11 & 13 DISK FRAME, 13F | 1 |

Disk Gang Assembly (All Models)

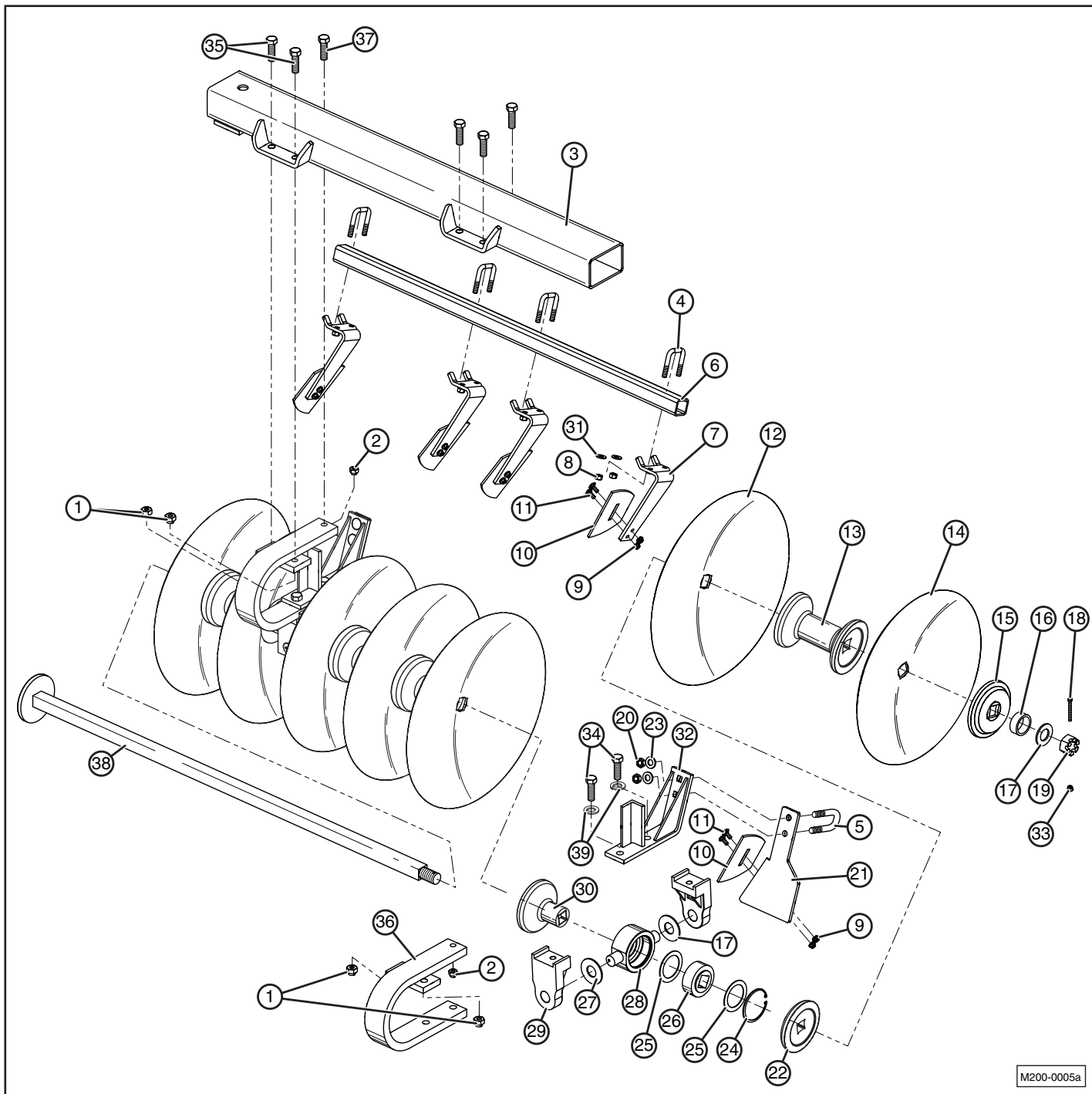

| Item | Part Number | Description | Qty. |
|-------|-----------------------------------------|----------------------------------------------------------------------------------------|------|
| 1 | NLT-7510 | NUT, TOP LOCK 3/4-10 | 4 |
| 2 | NLT-6311 | NUT, TOP LOCK 5/8-11 | 2 |
| 3 | QT-1059 | DISK MNT TUBE, FRONT LT 7 | 1 |
| | QT-1060 | DISK MNT TUBE, FRONT RT 7 | |
| | QT-1165 | DISK MNT TUBE, REAR LT 7 | |
| | QT-1166 | DISK MNT TUBE, REAR RT 7 | |
| | 10499 | DISK MNT TUBE, FRONT LT 9 | |
| | 10500 | DISK MNT TUBE, FRONT RT 9 | |
| | QT-1061 | DISK MNT TUBE, REAR LT 9 | |
| | QT-1062 | DISK MNT TUBE, REAR RT 9 | |
| | 12931 | DISK MNT TUBE, FRONT LT 11 | |
| | 12932 | DISK MNT TUBE, FRONT RT 11 | |
| | QT-1065 | DISK MNT TUBE, REAR LT 11 | |
| | QT-1066 | DISK MNT TUBE, REAR RT 11 | |
| | QT-1067 | DISK MNT TUBE, FRONT LT 13 | |
| | QT-1068 | DISK MNT TUBE, FRONT RT 13 | |
| | QT-1069 | DISK MNT TUBE, REAR LT 13 | |
| | QT-1070 | DISK MNT TUBE, REAR RT 13 | |
| | 10559 | DISK MNT TUBE, FRONT LT CNTR, 215F, 217F | |
| | 10560 | DISK MNT TUBE, FRONT RT CNTR, 215F, 217F | |
| | 11340 | DISK MNT TUBE, FRONT LT WING, 215F | |
| | 11408 | DISK MNT TUBE, FRONT LT WING, 217F | |
| 11342 | DISK MNT TUBE, FRONT RT WING, 215F | | |
| 11409 | DISK MNT TUBE, FRONT RT WING, 217F | | |
| 11284 | DISK MNT TUBE, REAR LT CNTR, 215F, 217F | | |
| 11285 | DISK MNT TUBE, REAR RT CNTR, 215F, 217F | | |
| 11278 | DISK MNT TUBE, REAR LT WING, 215F | | |
| 11410 | DISK MNT TUBE, REAR LT WING, 217F | | |
| 11279 | DISK MNT TUBE, REAR RT WING, 215F | | |
| 11411 | DISK MNT TUBE, REAR RT WING, 217F | | |
| 4 | BU-1223 | U-BOLT 1/2 x 2 x 3 | * |
| 5 | BU-5824 | U-BOLT 5/8 x 2 x 3 | 2 |
| 6 | 10541 | SCRAPER TUBE, FRONT 7, FRONT 11, FRONT INSIDE 13, FRONT WING 17 | 1 |
| | 10542 | SCRAPER TUBE, REAR 7, FRONT 9, REAR CENTER 13F, REAR WING 17 | |
| | 10543 | SCRAPER TUBE, REAR 9 | |
| | 10545 | SCRAPER TUBE, REAR OUTSIDE 11, REAR WING 15 | |
| | 10546 | SCRAPER TUBE, FRONT 11, REAR INSIDE 11, FRONT INSIDE 13, REAR INSIDE 13, REAR WING 13F | |
| | 10547 | SCRAPER TUBE, REAR OUTSIDE 13 | |
| | 10548 | SCRAPER TUBE, FRONT CENTER 15 | |
| | 10549 | SCRAPER TUBE, FRONT WING 15, REAR CENTER 15 | |

| Item | Part Number | Description | Qty. |
|------|-------------|------------------------------------------------|------|
| 7 | 10493 | SCRAPER ARM, LT | * |
| | 10494 | SCRAPER ARM, RT | |
| 8 | NH-5013 | 1/2-13 FLANGED LOCK NUT | * |
| 9 | NLF-3816 | NUT, LOCK, FLANGE, 3/8-16 | * |
| 10 | QT-1084 | SCRAPER WIDE | * |
| 11 | BC-3810 | BOLT, CARRIAGE, 3/8-16 x 1" | * |
| 12 | QT-1003 | DISK BLADE 24 x 2-1/4 | * |
| 13 | QT-1136 | DISK GANG SPACER | * |
| 14 | QT-1004 | DISK BLADE 22 x 2-1/2 | * |
| 15 | RD-4471 | DISK GANG TENSION WASHER | 1 |
| 16 | RD-4843 | DISK END SPACER | 1 |
| 17 | RD-4842 | DISK GANG WASHER | 3 |
| 18 | BH-2525 | BOLT, 1/4 - 20 X 2 1/2 GD 5 | 1 |
| 19 | NC-1406 | NUT, CASTLE 1-3/8 | 1 |
| 20 | NH-6311 | NUT, HEX, 5/8-11 | 4 |
| 21 | 10539 | SCRAPER SPRING GUARD, LT | 2 |
| | 10540 | SCRAPER SPRING GUARD, RT | |
| 22 | QT-1138 | DISK BEARING SPOOL, CONVEX | 1 |
| 23 | LW-0063 | WASHER, LOCK, 5/8 | 4 |
| 24 | QT-1147 | SNAP RING, 4" | 2 |
| 25 | QT-1146 | BEARING HOUSING SPACER (1 ON EACH SIDE OF BRG) | 4 |
| 26 | QT-1056 | DISK BEARING, 1-1/2 SQ, TRUNNION | 2 |
| 27 | FW-0138 | FLAT WASHER, 1-3/8 | 2 |
| 28 | QT-1144 | BEARING HOUSING, TRUNNION | 2 |
| 29 | QT-1081 | BEARING MOUNT, TRUNNION | 4 |
| 30 | QT-1137 | DISK BEARING SPOOL, CONCAVE | 1 |
| 31 | LW-0050 | LOCK WASHER 1/2" | * |
| 32 | 10491 | SCRAPER SPRING BRACKET | 2 |
| 33 | NLT-2520 | NUT, TOP LOCK 1/4-20 | 1 |
| 34 | BHY-7525 | BOLT, 3/4 X 2-1/2 GR8 | 4 |
| 35 | BHY-7535 | BOLT, 3/4-10 X 3-1/2, GR8 | 4 |
| 36 | RD-4470 | DISK SPRING, C-SHAPE, 3-HOLE | 2 |
| 37 | BH-6325 | BOLT, 5/8-11 X 2-1/2 | 2 |
| 38 | QT-1071 | DISK GANG SHAFT, 5 BLADE | 1 |
| | QT-1072 | DISK GANG SHAFT, 6 BLADE | |
| | QT-1073 | DISK GANG SHAFT, 7 BLADE | |
| | QT-1074 | DISK GANG SHAFT, 8 BLADE | |
| | QT-7075 | DISK GANG SHAFT, 9 BLADE | |
| 39 | LW-0075 | LOCK WASHER 3/4" | 4 |

*Quantities vary

Folding Disk Mount Tube Assembly (Model QT-213F Rear Only)

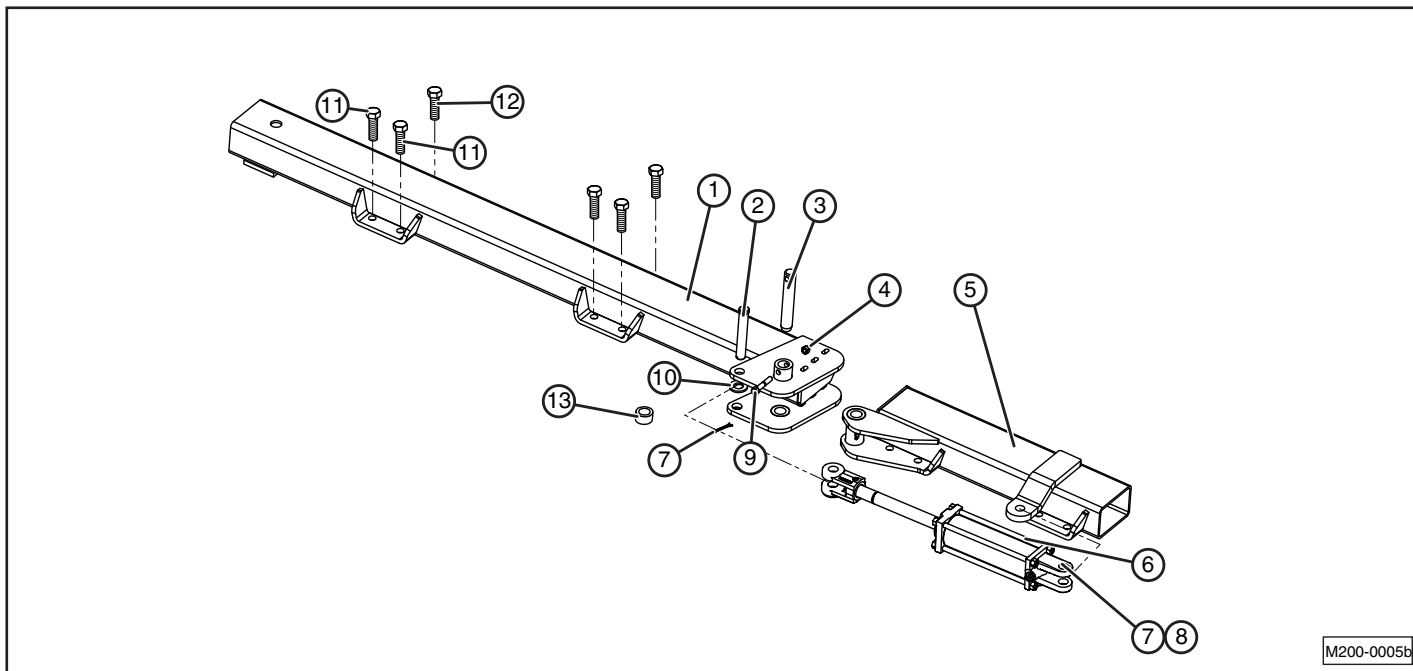

M200-0005b

| Item | Part Number | Description | Qty. |
|------|-------------|--------------------------------------------------------|------|
| 1 | QT-1203 | DISK MOUNT TUBE, REAR LEFT CENTER, GANGED BLADES | 1 |
| | QT-1204 | DISK MOUNT TUBE, REAR RIGHT CENTER, GANGED BLADES | |
| | 11287 | DISK MOUNT TUBE, REAR LEFT CENTER, INDEPENDENT BLADES | |
| | 11291 | DISK MOUNT TUBE, REAR RIGHT CENTER, INDEPENDENT BLADES | |
| 2 | CL-1006 | PIN, CLEVIS, 1 x 6, GANGED BLADES | 1 |
| 3 | RT-2124 | PIN, 1-1/4 x 7-1/2 | 1 |
| 4 | NLT-5013 | NUT, TOP LOCK, 1/2-13 | 1 |
| 5 | QT-1205 | DISK MOUNT TUBE, REAR LEFT WING, GANGED BLADES | 1 |
| | QT-1206 | DISK MOUNT TUBE, REAR RIGHT WING, GANGED BLADES | |
| | 11214 | DISK MOUNT TUBE, REAR LEFT WING, INDEPENDENT BLADES | |
| | 11292 | DISK MOUNT TUBE, REAR RIGHT WING, INDEPENDENT BLADES | |
| 6 | HYA-33008 | HYDRAULIC CYLINDER, 3 x 8 ASAE | 1 |
| 7 | CP-3620 | PIN, COTTER, 3/16 x 2 | 1 |
| 8 | HYO-2103 | CYLINDER CLEVIS PIN, 1 x 3 | 1 |
| 9 | BH-5028 | BOLT, HEX, 1/2-13 x 2-3/4 | 1 |
| 10 | FW-0100 | WASHER, FLAT, 1 | 1 |
| 11 | BHY-7535 | BOLT, 3/4-10 X 3-1/2, GR8 | 2 |
| 12 | BH-6325 | BOLT, 5/8-11 X 2-1/2 | 1 |
| 13 | RT-2054 | SPACER BUSHING, GANGED BLADES ONLY | 1 |

Independent Disk Blades

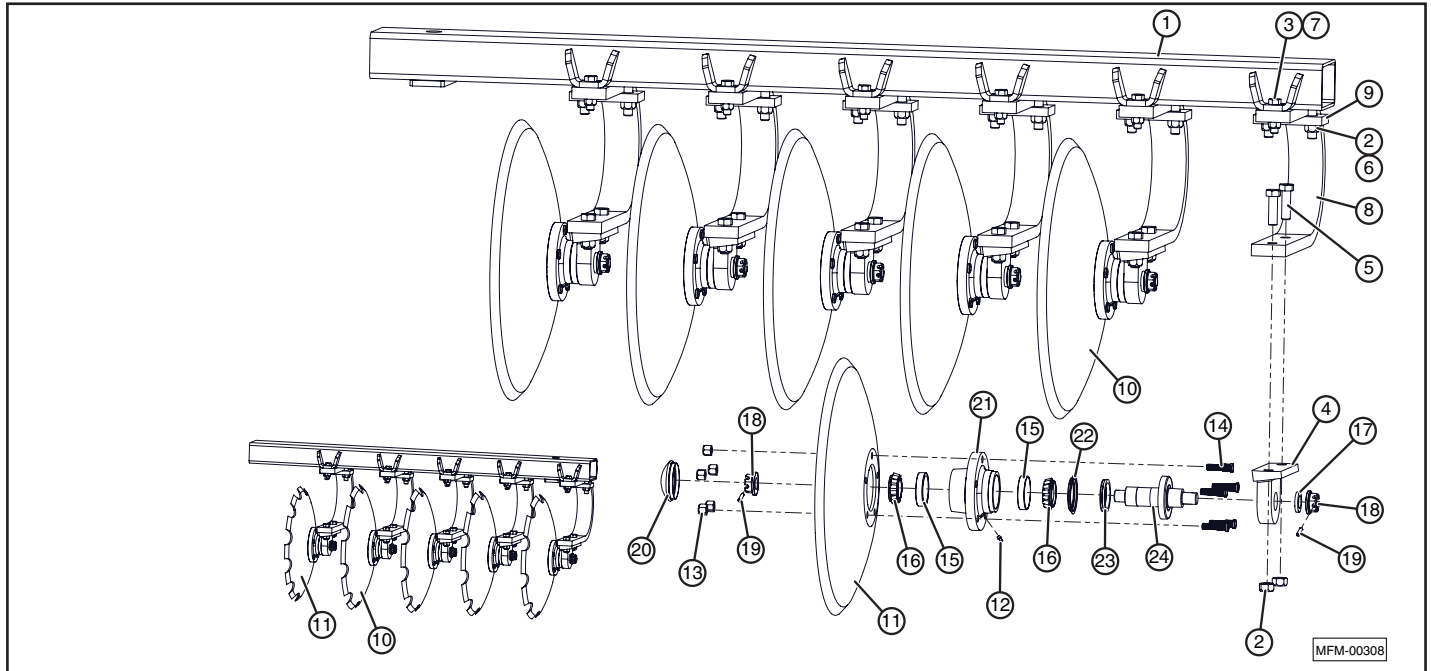

| Item | Part Number | Description | Qty. |
|------|-------------|-----------------------------------------|------|
| 1 | 11645 | DISK MNT TUBE, FRONT LT, 207 | 1 |
| | 11646 | DISK MNT TUBE, FRONT RT, 207 | |
| | 11647 | DISK MNT TUBE, REAR LT, 207 | |
| | 11648 | DISK MNT TUBE, REAR RT, 207 | |
| | 11199 | DISK MNT TUBE, FRONT LT, 209 | |
| | 11201 | DISK MNT TUBE, FRONT RT, 209 | |
| | 11198 | DISK MNT TUBE, REAR LT, 209 | |
| | 11203 | DISK MNT TUBE, REAR RT, 209 | |
| | 11649 | DISK MNT TUBE, FRONT LT, 211 | |
| | 11650 | DISK MNT TUBE, FRONT RT, 211 | |
| | 11651 | DISK MNT TUBE, REAR LT, 211 | |
| | 11652 | DISK MNT TUBE, REAR RT, 211 | |
| | 11205 | DISK MNT TUBE, FRONT LT, 213F | |
| | 11290 | DISK MNT TUBE, FRONT RT, 213F | |
| | 11287 | DISK MNT TUBE, REAR LT CTR, 213F | |
| | 11291 | DISK MNT TUBE, REAR RT CTR, 213F | |
| | 11214 | DISK MNT TUBE, REAR LT WING, 213F | |
| | 11292 | DISK MNT TUBE, REAR RT WING, 213F | |
| | 11179 | DISK MNT TUBE, FRONT LT CTR, 215F, 217F | |
| | 11196 | DISK MNT TUBE, FRONT RT CTR, 215F, 217F | |
| | 11177 | DISK MNT TUBE, FRONT LT WING, 215F | |
| | 11459 | DISK MNT TUBE, FRONT LT WING, 217F | |
| | 11194 | DISK MNT TUBE, FRONT RT WING, 215F | |
| | 11460 | DISK MNT TUBE, FRONT RT WING, 217F | |
| | 11183 | DISK MNT TUBE, REAR LT CNTR, 215F, 217F | |
| | 11288 | DISK MNT TUBE, REAR RT CNTR, 215F, 217F | |
| | 11180 | DISK MNT TUBE, REAR LT WING, 215F | |
| | 11461 | DISK MNT TUBE, REAR LT WING, 217F | |
| | 11245 | DISK MNT TUBE, REAR RT WING, 215F | |
| | 11462 | DISK MNT TUBE, REAR RT WING, 217F | |

| Item | Part Number | Description | Qty. |
|------|-------------------------|----------------------------------------------------------------------|------|
| 2 | NLT-7510 | NUT, TOP LOCK 3/4-10 | * |
| 3 | NLT-6311 | NUT, TOP LOCK 5/8-11 | * |
| 4 | 11675 | MOUNT, SPINDLE | * |
| 5 | BHY-7525 | BOLT, HEX, 3/4-10 x 2-1/2 GD8 | * |
| 6 | BHY-7535 | BOLT, HEX, 3/4-10 x 3-1/2, GD8 | * |
| 7 | BHY-6323 | BOLT, HEX, 5/8-11 x 2-1/4 GD8 | * |
| 8 | 11149 | C-SPRING | * |
| 9 | RT-2611 | DISK SPRING CLAMP PLATE | * |
| 10 | 11357 11359 12903 | DISK, NOTCHED, 24" DISK, SMOOTH, 24" DISK, SERRATED, 24" | * |
| 11 | 11358 11360 12904 | **DISK, NOTCHED, 22" **DISK, SMOOTH, 22" **DISK, SERRATED, 22" | * |
| 12 | RD-4860 | GREASE ZERK | * |
| 13 | WN-0050 | LUG NUT, 1/2-20 | * |
| 14 | RD-4861 | STUD, 1/2-20 | * |
| 15 | RD-4858 | OUTER RACE | * |
| 16 | RD-4857 | BEARING | * |
| 17 | 11676 | WASHER, FLAT, SPINDLE | * |
| 18 | RD-4862 | NUT, FLANGE, 1-1/4 | * |
| 19 | RD-4863 | PIN, ROLL, 1/4 x 1-1/2 | * |
| 20 | 11677 | DUST CAP | * |
| 21 | 11672 | HUB, 5-BOLT | * |
| 22 | RD-4856 | SEAL, COUNTERFACE | * |
| 23 | 11674 | SEAL | * |
| 24 | 11673 | SPINDLE, GRASS GUARD | * |

*Quantities vary

**On outside of unit only. All other disk gangs have all 24" blades.

Axle Frame Assembly

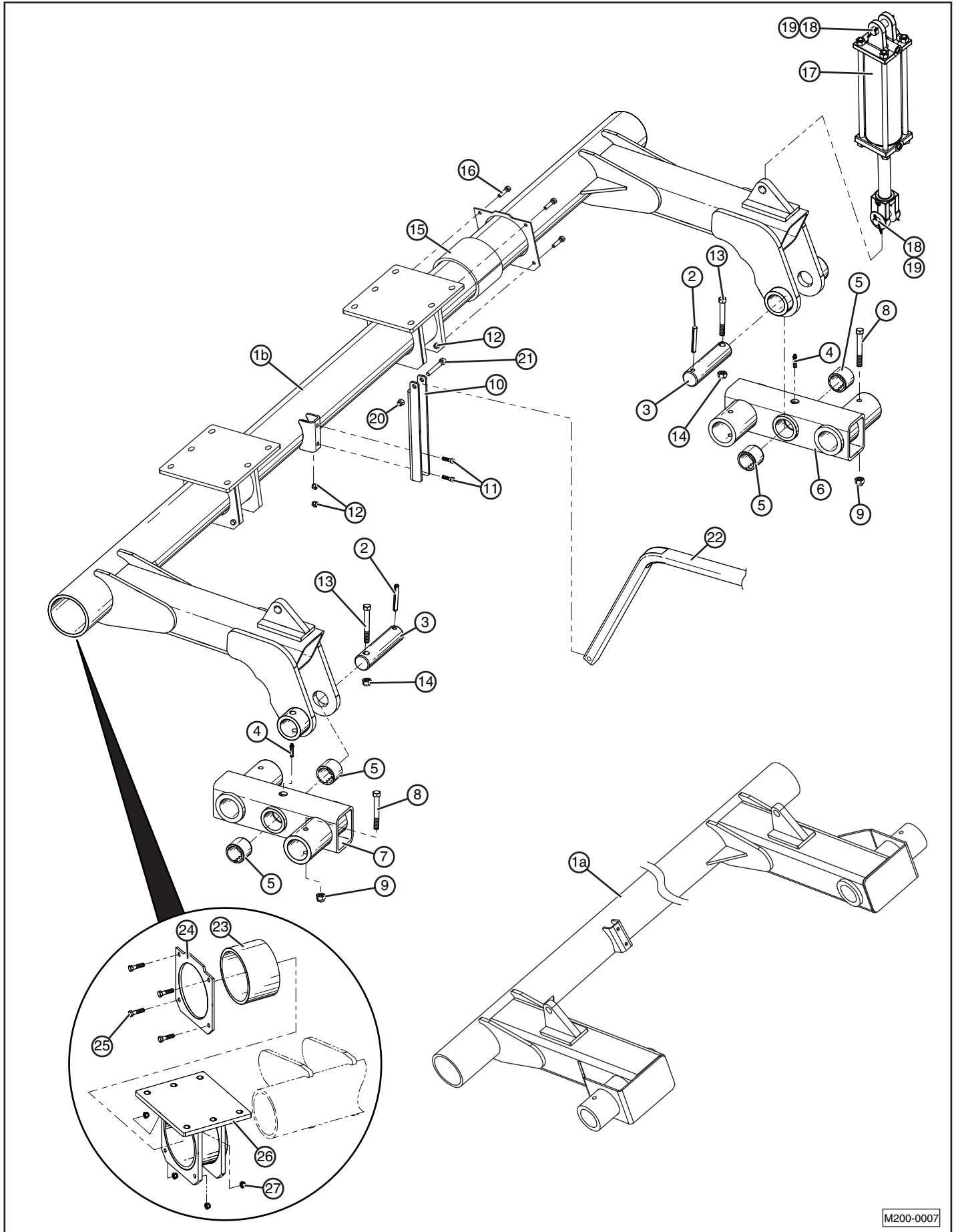

M200-0007

| Item | Part Number | Description | Qty. |
|------|-------------------------------|----------------------------------------------------------------------------|------|
| 1a | QT-1187 | AXLE ASSY (7) | 1 |
| 1b | QT-1197 QT-1200 QT-1259 | AXLE ASSY (9, 11) AXLE ASSY (13, 13F) AXLE ASSY (15F, 17F) | 1 |
| 2 | QT-1143 | PIN, SPRING ROLL 1/2 x 3-1/2" | 4 |
| 3 | QT-1183 | AXLE WALKER PIN | 2 |
| 4 | GZ-1310 | ZERK, GREASE | 2 |
| 5 | QT-1124 | BUSHING | 4 |
| 6 | QT-1123 QT-1312 | AXLE BEAM ASSY RIGHT AXLE BEAM ASSY RIGHT, 215F, 217F | 1 |
| 7 | QT-1015 QT-1311 | AXLE BEAM ASSY LEFT AXLE BEAM ASSY LEFT, 215F, 217F | 1 |
| 8 | BH-5045 BH-5050 | BOLT, 1/2 x 4-1/2 GD 5 (209) BOLT, 1/2 x 5 GD 5 (207, 213F, 215F, 217F) | 2 |
| 9 | NLT-5013 | NUT, TOP LOCK, 1/2-13 | 2 |
| 10 | QT-1139 | HYDRAULIC STOP AXLE BRACKET | 1 |
| 11 | BH-3810 | BOLT, 3/8 - 16 x 1 GD 5 | 2 |
| 12 | NLT-3816 | NUT, TOP LOCK, 3/8 - 16 | 2 |
| 13 | BH-7540 | BOLT, 3/4-11 x 4 GD 5 | 2 |
| 14 | NLT-7511 | NUT, TOP LOCK, 3/4-11 | 2 |
| 15 | QT-1173 | AXLE MOUNT UHMW INSERT, SPLIT | 2 |
| 16 | BH-3815 | BOLT, 3/8 - 10 x 1-1/2" GD 5 | 4 |
| 17 | HYC-34012 | CYLINDER, HYDRAULIC 4 x 12 | 1 |
| 18 | HYO-2103 | CYLINDER CLEVIS PIN, 1 x 3 | 2 |
| 19 | CP-3620 | COTTER PIN, 3/16 x 2 | — |
| 20 | NLT-5013 | NUT, TOP LOCK 1/2 - 13 | 1 |
| 21 | BH-5028 | BOLT, 1/2-16 x 2-3/4 GD 5 | 1 |
| 22 | QT-1021 | HYD STOP TUBE | 1 |
| 23 | QT-1133 | AXLE MOUNT UHMW INSERT | 1 |
| 24 | QT-1132 | AXLE MOUNT CAP | 1 |
| 25 | BH-3815 | BOLT, 3/8-16 x 1-1/2" GRADE 5 | 4 |
| 26 | QT-1130 | AXLE MOUNT ASSY | 1 |
| 27 | NLT-3816 | NUT, TOP LOCK 3/8-16 | 4 |

Spindle, Hub, and Wheels

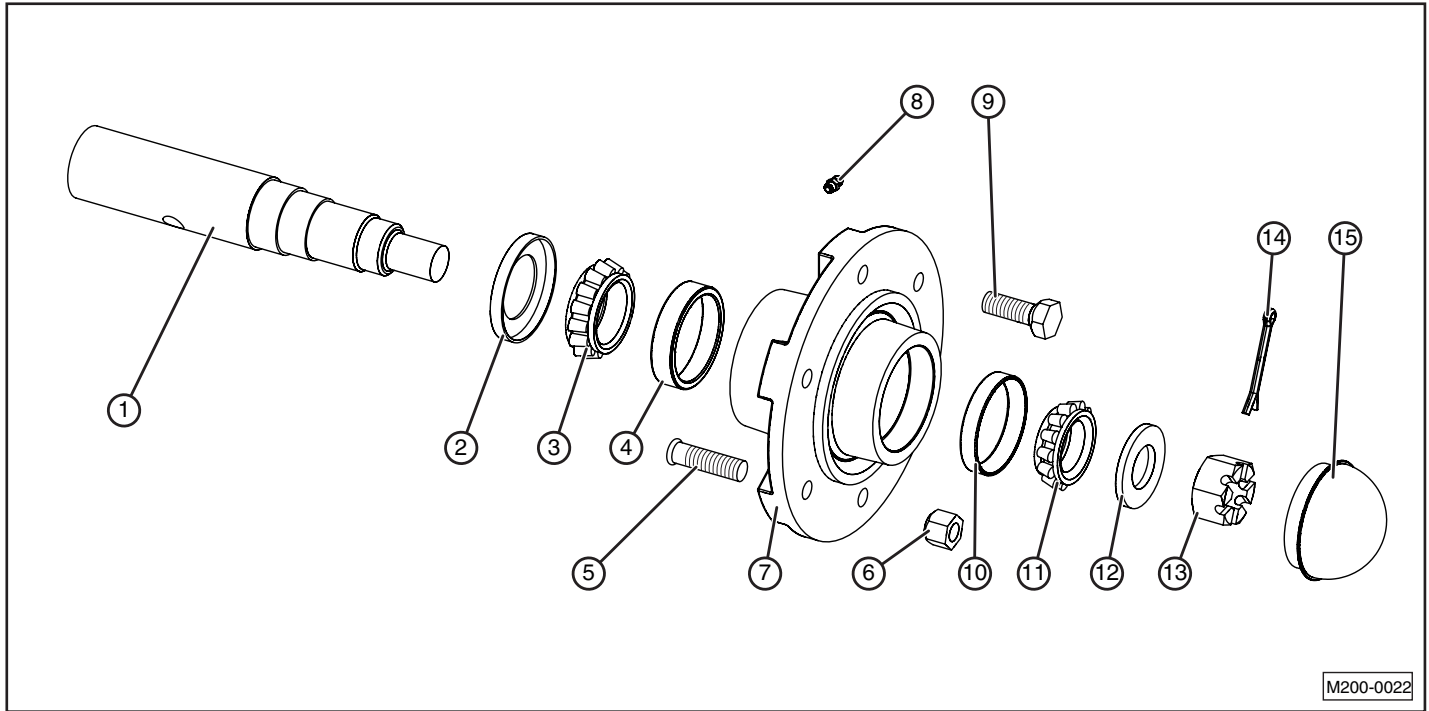

| Item | Part Number | Description |
|--------------------------------------------------------------------|--------------|---------------------------------------|
| QT-209, QT-211, QT-213, and QT-213F 8 BOLT HUB, 6000 LB | | |
| 1 | RT-3180 | SPINDLE, 2 3/4 X 12 1/2 |
| 2 | RT-3182 | GREASE SEAL, 8 BOLT HD HUB |
| 3 | RT-3183 | INNER BEARING |
| 4 | RT-3191 | INNER RACE |
| 5 | RT-3193 | WHEEL STUD 5/8-18 X 2 1/2 |
| 6 | WN-0063 | WHEEL NUTS 5/8 |
| 7 | RT-3184 | HUB WITH RACES, 6 HOLE HUB |
| 8 | GZ-0601 | GREASE ZERK |
| 9 | N/A | WHEEL BOLTS |
| 10 | RT-3192 | OUTER RACE |
| 11 | RT-3186 | OUTER BEARING |
| 12 | RT-3190 | SPINDLE FLAT WASHER |
| 13 | RT-3187 | SPINDLE HEX CASTLE NUT |
| 14 | CP-7320 | COTTER PIN (0.207 X 2) |
| 15 | RT-3188 | DUST CAP |
| | RT-3181 | 8-BOLT HUB ASSEMBLY, 6000LB |
| NS | IF 320/70R15 | TIRE, (9-SHANK) |
| | 14L-16.1 14T | TIRE, 14 PLY (13-SHANK) |
| | IF 320/70R15 | TIRE, (11-SHANK) |
| NS | RT-2179 | RIM, 15 x 10, 8 BOLT (9 AND 11-SHANK) |
| | QT-1241 | RIM, 16.1 x 11, 8-BOLT (13-SHANK) |

| Item | Part Number | Description |
|-------------------------------------------------------------|----------------|------------------------------------|
| QT-207, QT-215F, and QT-217F 8 BOLT HUB, 7500 LB | | |
| 1 | RD-4416 | SPINDLE, 3 X 12 1/2 |
| 2 | RD-4582 | GREASE SEAL, 8 BOLT 7500 LB HUB |
| 3 | RD-4583 | INNER BEARING |
| 4 | RD-4584 | INNER RACE |
| 5 | RT-3193 | WHEEL STUD 5/8-18 X 2 1/2 |
| 6 | NLF-6318 | NUT, FLANGED LOCK, 5/8-11 |
| 7 | RD-4581 | HUB WITH RACES, 8 BOLT 7500 LB HUB |
| 8 | GZ-0601 | GREASE ZERK |
| 9 | N/A | WHEEL BOLTS |
| 10 | RT-3192 | OUTER RACE |
| 11 | RT-3186 | OUTER BEARING |
| 12 | RT-3190 | SPINDLE FLAT WASHER |
| 13 | RT-3187 | SPINDLE HEX CASTLE NUT |
| 14 | CP-7320 | COTTER PIN (0.207 X 2) |
| 15 | RT-3188 | DUST CAP |
| NS | RD-4580 | 8-BOLT HUB ASSEMBLY, 7500LB |
| NS | 16.5L-16.1 14T | TIRE, 14 PLY, 215F |
| NS | 16.5L-16.1 20T | TIRE, 20 PLY, 207, 217F |
| NS | QT-1242 | RIM, 16.1 x 14, 8-BOLT, 7000 LB. |

Spindle and Hub (Continued)

| Item | Part Number | Description |
|----------------------------------------------------------------|-------------|-----------------------------------------------------|
| QT-215F AND QT-217F Gauge Wheel 6-HOLE HUB, 3560 LB | | |
| 1 | WDL-2505 | SPINDLE, 1 3/4 X 9 1/2 |
| 2 | HD-1360 | GREASE SEAL, 6 HOLE HUB |
| 3 | HD-1362 | INNER BEARING |
| 4 | HD-1366 | INNER RACE |
| 5 | HD-1191 | HUB STUD |
| 6 | WN-0050 | STUD NUTS |
| 7 | HD-1361 | HUB WITH RACES, 6 HOLE HUB |
| 8 | GZ-0601 | GREASE ZERK |
| 9 | WB-5010 | WHEEL BOLTS |
| 10 | HD-1171 | OUTER RACE |
| 11 | HD-1363 | OUTER BEARING |
| 12 | HD-1364 | SPINDLE FLAT WASHER |
| 13 | HD-1365 | SPINDLE HEX CASTLE NUT |
| 14 | CP-1517 | COTTER PIN (0.150 X 1 3/4) |
| 15 | HD-1367 | DUST CAP |
| | HD-1371 | 6-HOLE HUB ASSEMBLY (INCLUDES ITEMS 2,3,7,11,15) |

Chisel Shank Assembly

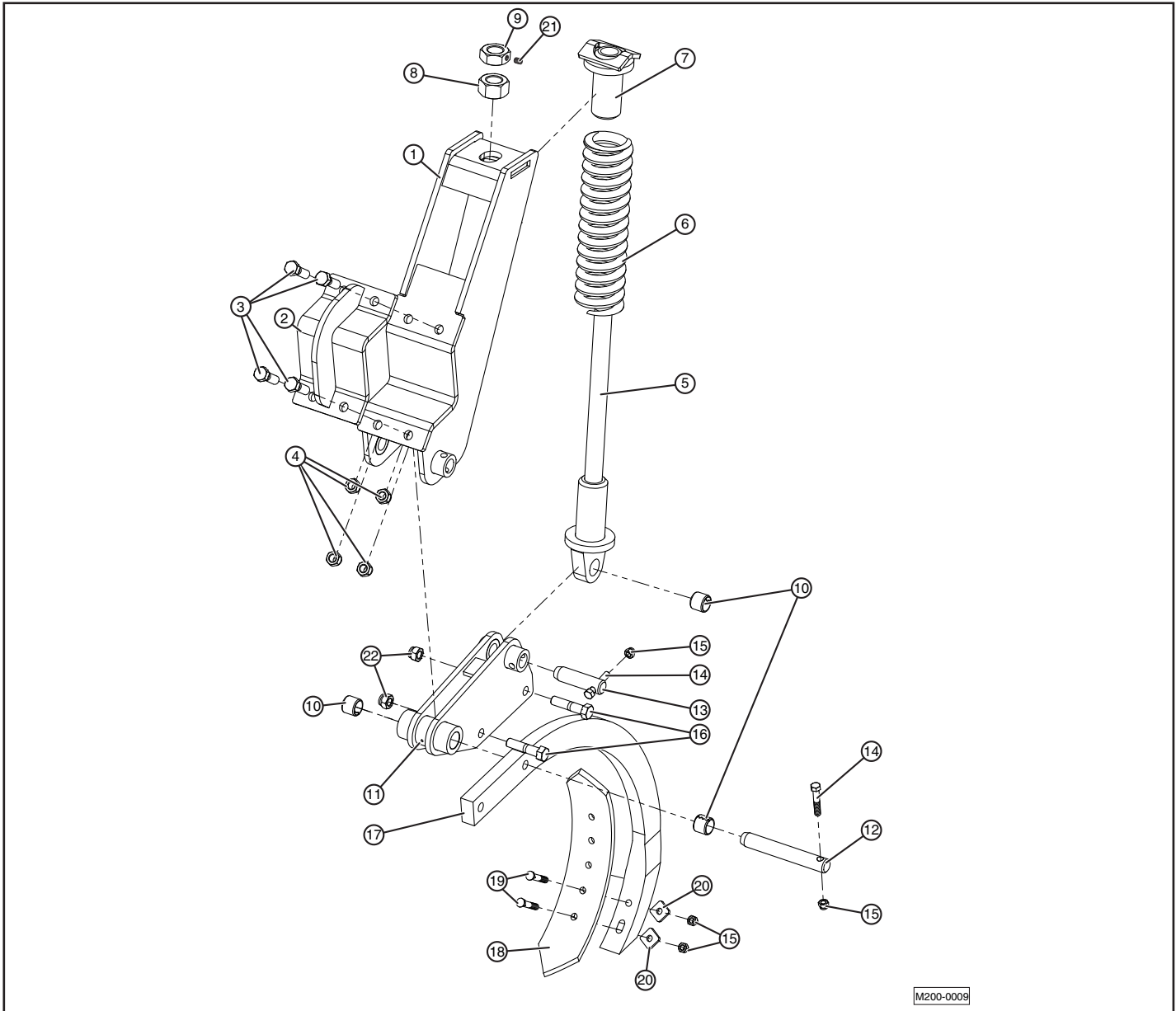

| Item | Part Number | Description | Qty. |
|------|-------------|---------------------------|------|
| 1 | QT-1174 | CHISEL MOUNT ASSY | 1 |
| 2 | QT-1178 | CHISEL CLAMP ASSY | 1 |
| 3 | BHY-7525 | BOLT, 3/4-10 X 2-1/2 GD 8 | 4 |
| 4 | NLT-7510 | NUT, TOP LOCK 3/4-10 | 6 |
| 5 | QT-1176 | CHISEL SPRING BASE ASSY | 1 |
| 6 | QT-1182 | SPRING, 4-3/8 X 17 | 1 |
| 7 | QT-1177 | GUIDE ASSY, CHISEL SPRING | 1 |
| 8 | NHF-1506 | NUT, FLANGE 1-1/2 - 6 | 1 |
| 9 | 10501 | NUT, JAM, 1-1/2 - 6 | 1 |
| 10 | QT-1179 | BUSHING, CHISEL SHANK | 3 |
| 11 | QT-1175 | CHISEL SHANK MOUNT ASSY | 1 |
| 12 | QT-1180 | CHISEL MOUNT PIVOT PIN | 1 |
| 13 | QT-1181 | CHISEL SPRING PIVOT PIN | 1 |
| 14 | BH-5028 | BOLT, 1/2-13 X 2-3/4 | 2 |

| Item | Part Number | Description | Qty. |
|------|-----------------------------------------------------|---------------------------------------------------------------------------------------------------------------------------------------------------------------------------------------------|------|
| 15 | NLT-5013 | NUT, TOP LOCK 1/2-13 | 4 |
| 16 | BHY-7533 | BOLT, 3/4-10 X 3-1/4 GD 8 | 2 |
| 17 | QT-1006 | CHISEL SHANK | 1 |
| 18 | QT-1053 QT-1051 QT-1052 QT-1054 QT-1055 | CHISEL POINT, 2" STRAIGHT CHISEL SHOVEL, 3" TWISTED, LEFT HAND CHISEL SHOVEL, 3" TWISTED, RIGHT HAND CHISEL SHOVEL, 4" TWISTED, LEFT HAND CHISEL SHOVEL, 4" TWISTED, RIGHT HAND | 1 |
| 19 | QT-1227 BHY-5030 | PLOW BOLT, 1/2-13 X 3 (FOR 3" AND 4" TWISTED SHOVELS) BOLT, 1/2 X 13 X 3", GRADE 8 (FOR 2" STRAIGHT POINT) | 2 |
| 20 | HDD-016 | SQUARE WASHER, 1/2 | 2 |
| 21 | 10502 | SET SCREW, 3/8-16 x 3/8 | 1 |
| 22 | NLT-7510 | NUT, TOP LOCK 3/4-10 | 2 |

Leveler Disk Frame Arms

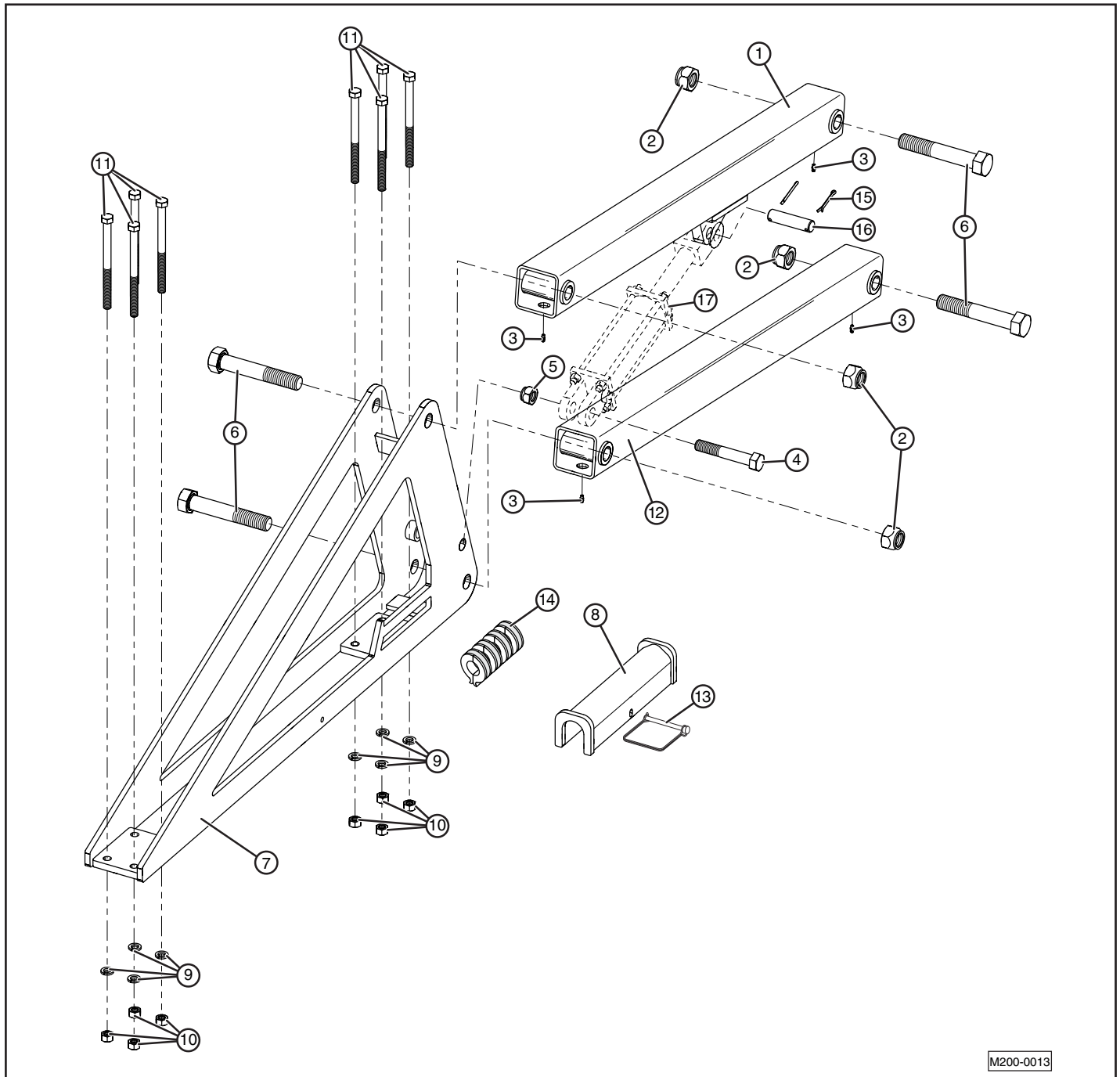

M200-0013

| Item | Part Number | Description | Qty. |
|------|-------------------------------|--------------------------------------------------------------------------------------------------------|------|
| 1 | QT-1043 | LEVELER LINKAGE TUBE CYL ASSY | 1 |
| 2 | NY-1307 | NUT, NYLON LOCK 1-1/4-7 | 2 |
| 3 | GZ-2528 | ZERK, GREASE | 4 |
| 4 | BHY-1070 | BOLT, 1 x 7 GRADE 8 | 4 |
| 5 | NLT-1008 | NUT, TOP LOCK 1-8 | 2 |
| 6 | BHY-1380 | BOLT, 1-1/4 x 8 GRADE 8 | 4 |
| 7 | QT-1040 QT-1041 QT-1303 | LEVELER FRAME MOUNT, LT LEVELER FRAME MOUNT, RT LEVELER FRAME MOUNT, RT, 213F, 215F, and 217F | 1 |
| 8 | HYS-1212 | CYLINDER LOCK ASSY 2 x 14 | 1 |

| Item | Part Number | Description | Qty. |
|------|----------------------|----------------------------------------------------------|------|
| 9 | LW-0063 | WASHER, LOCK 5/8 | 8 |
| 10 | NH-6311 | NUT, HEX 5/8-11 | 8 |
| 11 | BH-6385 | BOLT, 5/8-11 x 8-1/2 GRADE 5 | 8 |
| 12 | QT-1042 | LEVELER LINKAGE TUBE ASSY | 1 |
| 13 | LP-3825 | LINCH PIN 3/8 x 2-1/2 | 1 |
| 14 | HYS-1312 | CYLINDER COLLAR SET, 1 3/8-1/2 HD SHORT SET | 1 |
| 15 | CP-3620 | COTTER PIN, 3/16 x 2 | 2 |
| 16 | HYO-2103 | CYLINDER CLEVIS PIN, 1 x 3 | 1 |
| 17 | HYR-4008 HYR-3808 | HYDRAULIC CYLINDER 4 x 8 HYDRAULIC CYLINDER 3-3/4 x 8 | 1 |

Leveler Disk Assembly

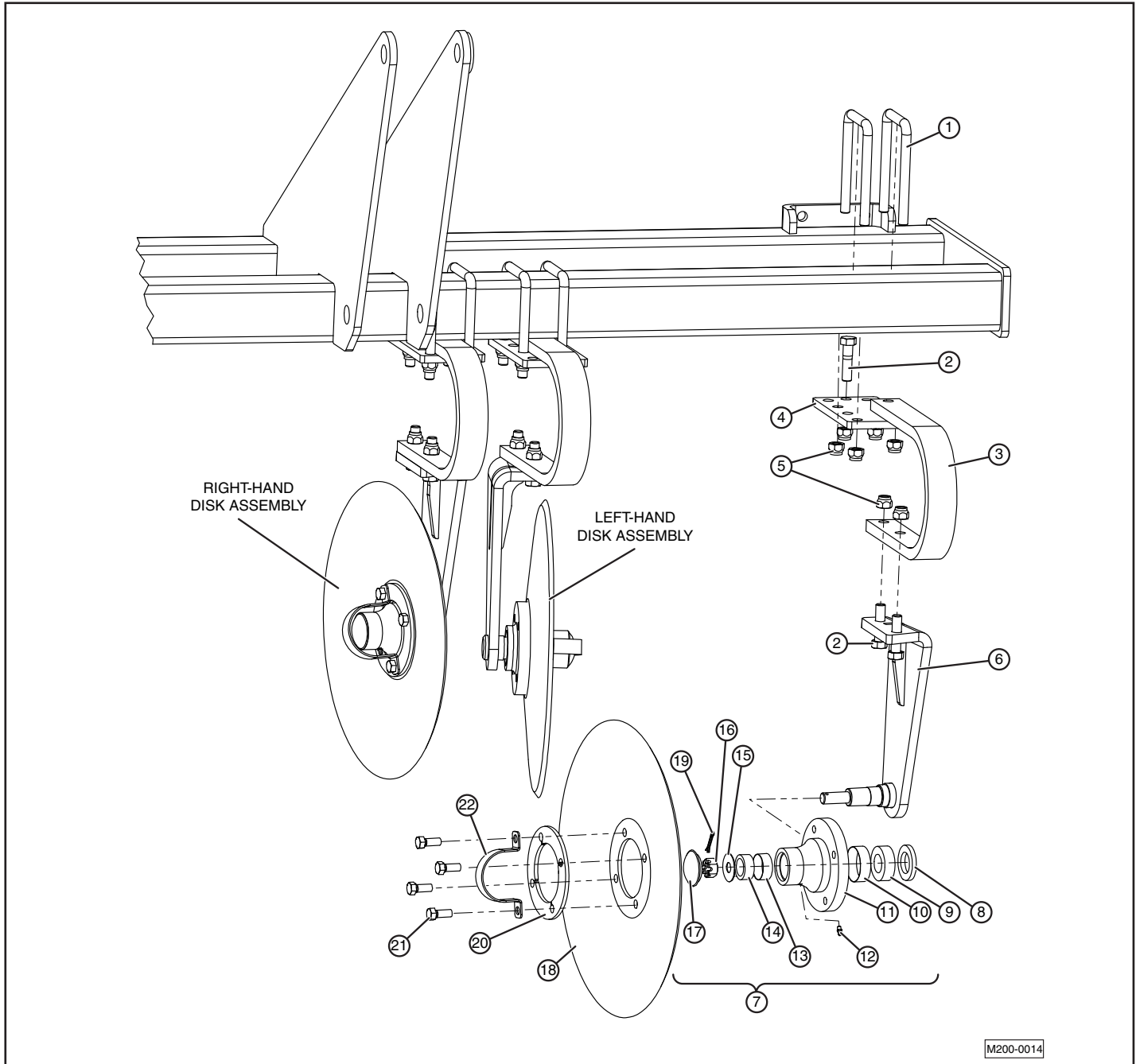

| Item | Part Number | Description | Qty. |
|------|--------------------|-------------------------------------------------------|------|
| 1 | BU-5846 | U-BOLT 5/8-11 x 4 x 6-1/2 | 2 |
| 2 | BH-6325 | BOLT, 5/8-11 x 2-1/2 GD 5 | 3 |
| 3 | QT-1027 | SPRING, LEVELER DISK | 1 |
| 4 | QT-1028 | CLAMP, LEVELER DISK SPRING | 7 |
| 5 | NLT-6311 | NUT, TOP LOCK 5/8-11 | 1 |
| 6 | QT-1023 QT-1024 | LEVELER DISK MOUNT, LEFT LEVELER DISK MOUNT, RIGHT | 4 |
| 7 | HD-1170 | HUB, 4 BOLT ASSY. ITEMS 8-14, 17 | 1 |
| 8 | HD-1160 | GREASE SEAL | 1 |
| 9 | HD-1162 | INNER BEARING | 1 |
| 10 | HD-1171 | INNER RACE | 1 |
| 11 | HD-1161 | HUB WITH RACES, 4 HOLE | 1 |

| Item | Part Number | Description | Qty. |
|------|-------------|----------------------------|------|
| 12 | GZ-2528 | ZERK, GREASE | 1 |
| 13 | HD-1172 | OUTER RACE | 1 |
| 14 | HD-1163 | OUTER BEARING | 1 |
| 15 | HD-1164 | SPINDLE FLAT WASHER | 1 |
| 16 | HD-1165 | SPINDLE CASTLE NUT | 1 |
| 17 | HD-1167 | DUST CAP | 1 |
| 18 | QT-1025 | LEVELER DISK BLADE | 1 |
| 19 | CP-5312 | PIN, COTTER, 0.150 x 1-1/4 | 1 |
| 20 | QT-1026 | LEVELER DISK HUB PLATE | 1 |
| 21 | BHF-5013 | BOLT, 1/2-20 x 1-1/4 GD 8 | 1 |
| 22 | RD-5092 | HUB RETAINER | 1 |

Leveler Disk Frame (QT-207, 209, 211, and 213)

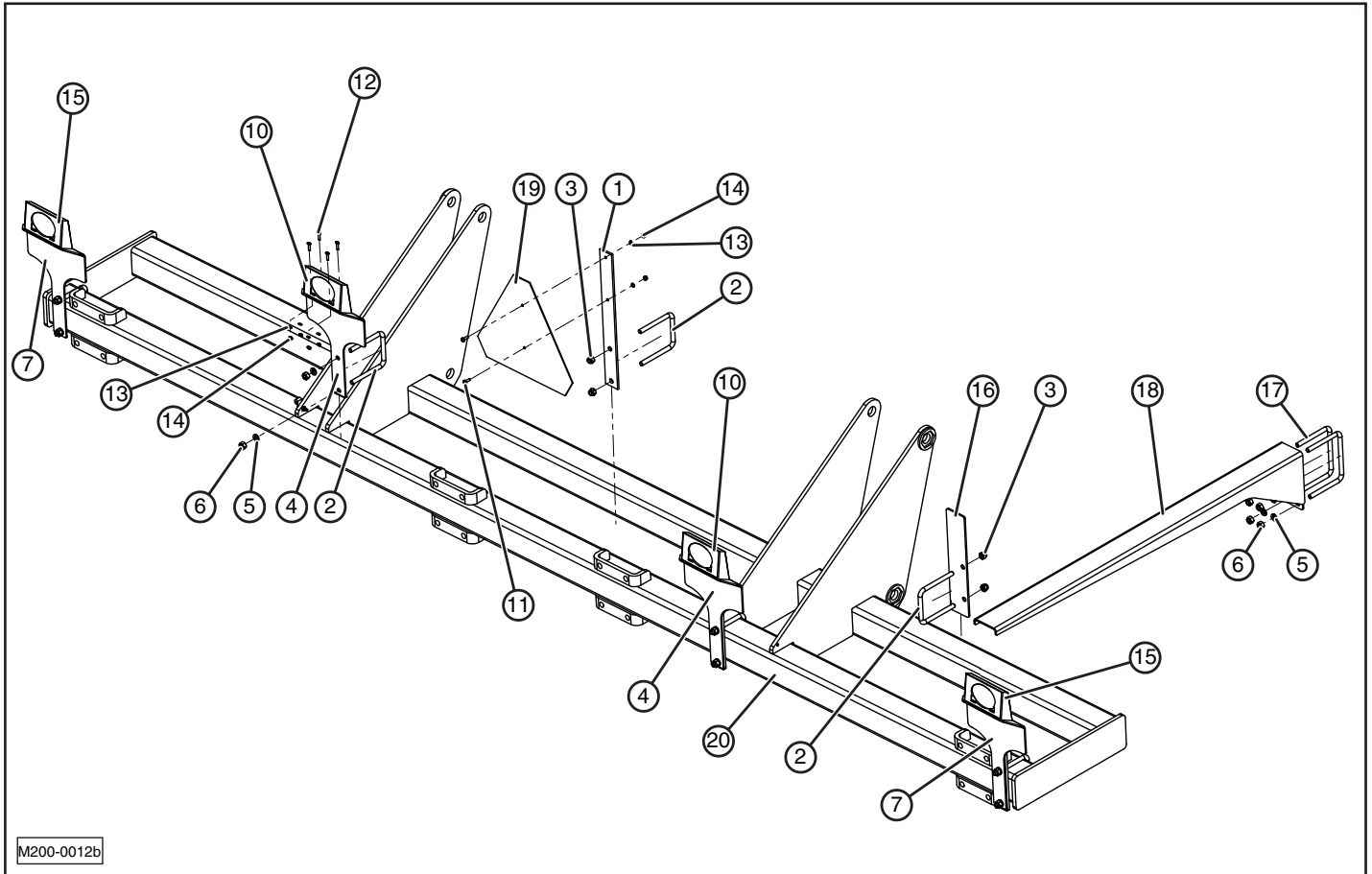

M200-0012b

| Item | Part Number | Description | Qty. |
|------|-------------|------------------------------------------|------|
| 1 | QT-1134 | SMV MOUNT BRACKET 4 | 1 |
| 2 | BU-1245 | U-BOLT, 1/2-13 x 4-1/2 | 6 |
| 3 | NLT-5013 | NUT, TOP LOCK 1/2-13 | 4 |
| 4 | RD-5056 | BRACKET, LIGHT, SINGLE, INNER | 2 |
| 5 | LW-0050 | WASHER, LOCK 1/2 | 12 |
| 6 | NH-5013 | NUT, 1/2-13 | 12 |
| 7 | 11128 | BRACKET, LIGHT, SINGLE, OUTER (207-213F) | 2 |
| 8 | — | — | — |
| 9 | — | — | — |
| 10 | LB-1107 | LIGHT, RED | 2 |
| 11 | BH-2575 | BOLT, 1/4-20 x 3/4 | 2 |
| 12 | BH-2513 | BOLT, 1/4-20 x 1-1/4 | 18 |

| Item | Part Number | Description | Qty. |
|------|------------------------------------------|----------------------------------------------------------------------------------------|------|
| 13 | LW-0025 | WASHER, LOCK 1/4 | 18 |
| 14 | NH-2520 | NUT, 1/4-20 | 18 |
| 15 | LB-1106 | LIGHT, AMBER | 2 |
| 16 | QT-1050 | LEVELER DEPTH GAUGE | 1 |
| 17 | BU-1265 | U-BOLT, 1/2 x 5-1/4 x 6 | 2 |
| 18 | QT-1226 | LEVELER GAUGE INDICATOR ASSY | 1 |
| 19 | MM-1300 | SMV SIGN | 1 |
| 20 | QT-1160 QT-1044 QT-1045 QT-1046 | LEVELER TOOLBAR, 7 LEVELER TOOLBAR, 9 LEVELER TOOLBAR, 11 LEVELER TOOLBAR, 13 | 1 |

Leveler Disk Frame (QT-213F, QT-215F, and QT-217F)

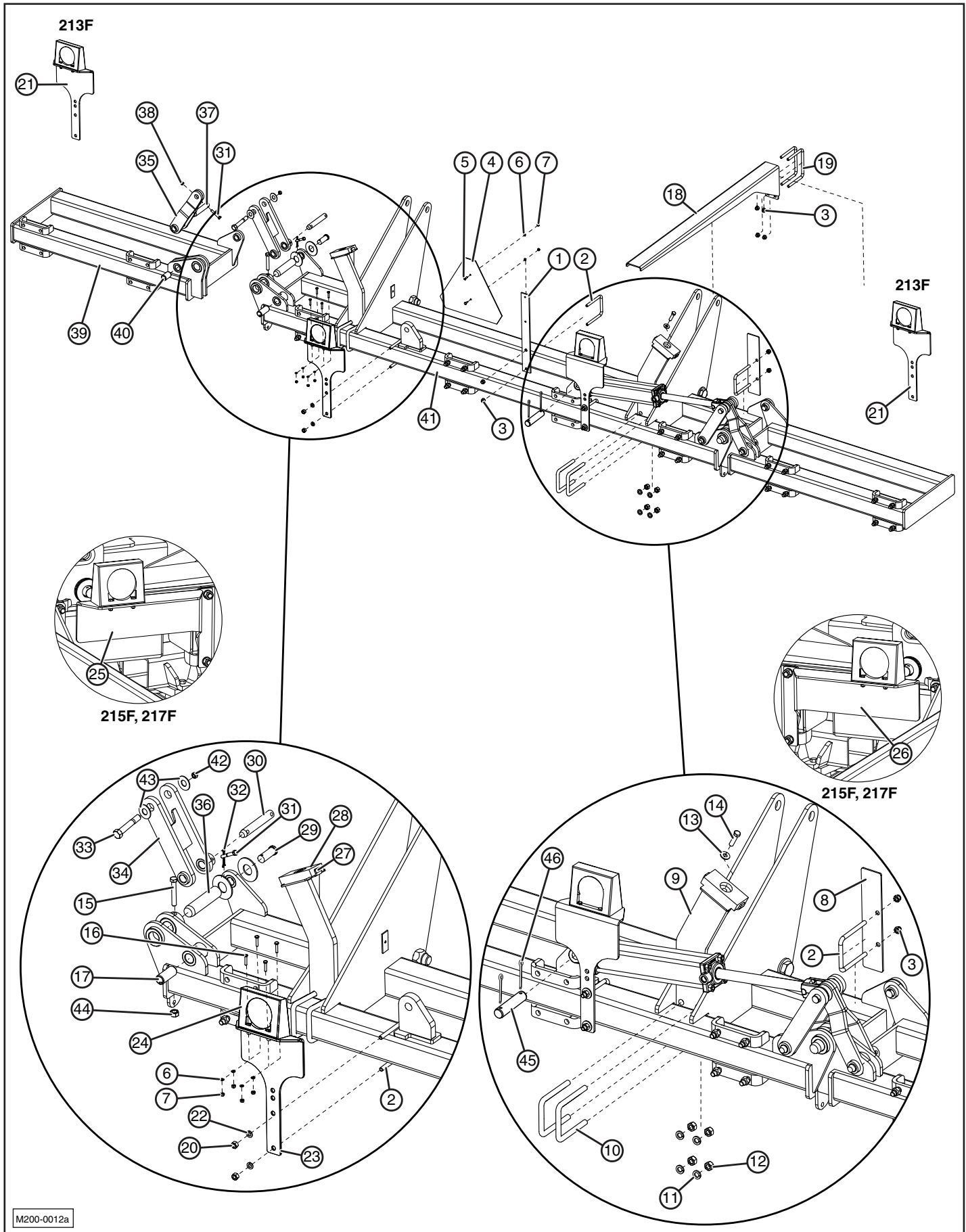

| Item | Part Number | Description | Qty. |
|------|--------------------|---------------------------------------------|------|
| 1 | QT-1134 | SMV MOUNT BRACKET | 1 |
| 2 | BU-1245 | U-BOLT, 1/2-13 x 4 x 5 | 3 |
| 3 | NLT-5013 | NUT, TOP LOCK 1/2-13 | 8 |
| 4 | MM-1300 | SMV SIGN | 1 |
| 5 | BH-2575 | BOLT, 1/4-20 x 3/4 | 2 |
| 6 | LW-0025 | WASHER, LOCK 1/4 | 10 |
| 7 | NH-2520 | NUT, 1/4-20 | 10 |
| 8 | QT-1049 | LEVELER DEPTH GAUGE | 1 |
| 9 | QT-1235 QT-1225 | REST, WING REST, WING | 1 |
| 10 | BU-5845 | U-BOLT, 5/8-11 x 4 x 5 | 4 |
| 11 | LW-0063 | WASHER, LOCK 5/8 | 8 |
| 12 | NH-6311 | NUT, 5/8-11 | 8 |
| 13 | FW-0050 | WASHER, FLAT 1/2 | 2 |
| 14 | BH-5020 | BOLT, 1/2-13 x 2 | 2 |
| 15 | BHY-5635 | BOLT, HEX, 9/16 x 3-1/2 | 2 |
| 16 | BH-2513 | BOLT, 1/4-20 x 1-1/4 | 10 |
| 17 | QT-1148 | PIN, STRAIGHT, 1 x 6-1/2 | 2 |
| 18 | QT-1226 | LEVELER GAUGE INDICATOR ASSY | 1 |
| 19 | BU-1265 | U-BOLT, 1/2-13 x 6 x 5 | 2 |
| 20 | NH-5013 | NUT, 1/2-13 | 4 |
| 21 | 11128 | BRACKET, LIGHT, SINGLE, OUTER (207-213F) | 2 |
| 22 | LW-0050 | WASHER, LOCK 1/2 | 4 |
| 23 | RD-5056 | BRACKET, LIGHT, SINGLE, INNER | 2 |
| 24 | LB-1107 | LIGHT, RED | 2 |
| 25 | 11126 | BRACKET, LIGHT, LT | 1 |

| Item | Part Number | Description | Qty. |
|------|------------------------------------------|----------------------------------------------------------------------------------------------------------------------------------------|------|
| 26 | 11127 | BRACKET, LIGHT, RT | 1 |
| 27 | QT-1225 | REST, WING LH | 1 |
| 28 | RT-3415 | WING REST BUMPER | 1 |
| 29 | 10685 | PIN, CLEVIS, 1 x 3 | 2 |
| 30 | QT-1148 | DISK HITCH PIVOT PIN, REAR | 2 |
| 31 | BH-3823 | BOLT, HEX, 3/8-16 x 2-1/4 | 4 |
| 32 | CP-3620 | COTTER PIN, 3/16 x 2 | 4 |
| 33 | 10673 | BOLT, 1 x 7, GRADE 8 LONG SHOULDER | 2 |
| 34 | QT-1211 | DISK CENTER LINKAGE | 2 |
| 35 | QT-1212 | DISK WING LINKAGE | 2 |
| 36 | WD-2915 | CONNECTOR PIN | 2 |
| 37 | QT-1057 | DISK FRAME HITCH PIN | 2 |
| 38 | NLT-3816 | NUT, TOP LOCK, 3/8-16 | 4 |
| 39 | QT-1219 QT-1220 QT-1255 QT-1256 | LEVELER TOOLBAR WING, LT 13F, 17F LEVELER TOOLBAR WING, RT 13F, 17F LEVELER TOOLBAR WING, LT 15F LEVELER TOOLBAR WING, RT 15F | 1 |
| 40 | QT-1151 | DISK HITCH SPRING BUSHING | 2 |
| 41 | QT-1218 QT-1254 | LEVELER TOOLBAR, CENTER 13F LEVELER TOOLBAR, CENTER 15F, 17F | 1 |
| 42 | NLT -1008 | NUT, TOP LOCK, 1 - 8 | 2 |
| 43 | FW-0100 | WASHER, FLAT, 1" | 4 |
| 44 | NLT-5612 | NUT, TOP LOCK, 9/16-12 | 2 |
| 45 | HYO-2103 | PIN, STRAIGHT, 1 x 3-1/2 | 2 |
| 46 | CP-3620 | PIN, COTTER, 3/16 x 2.00 | 4 |

4-Bar Harrow Lift Arm Assembly

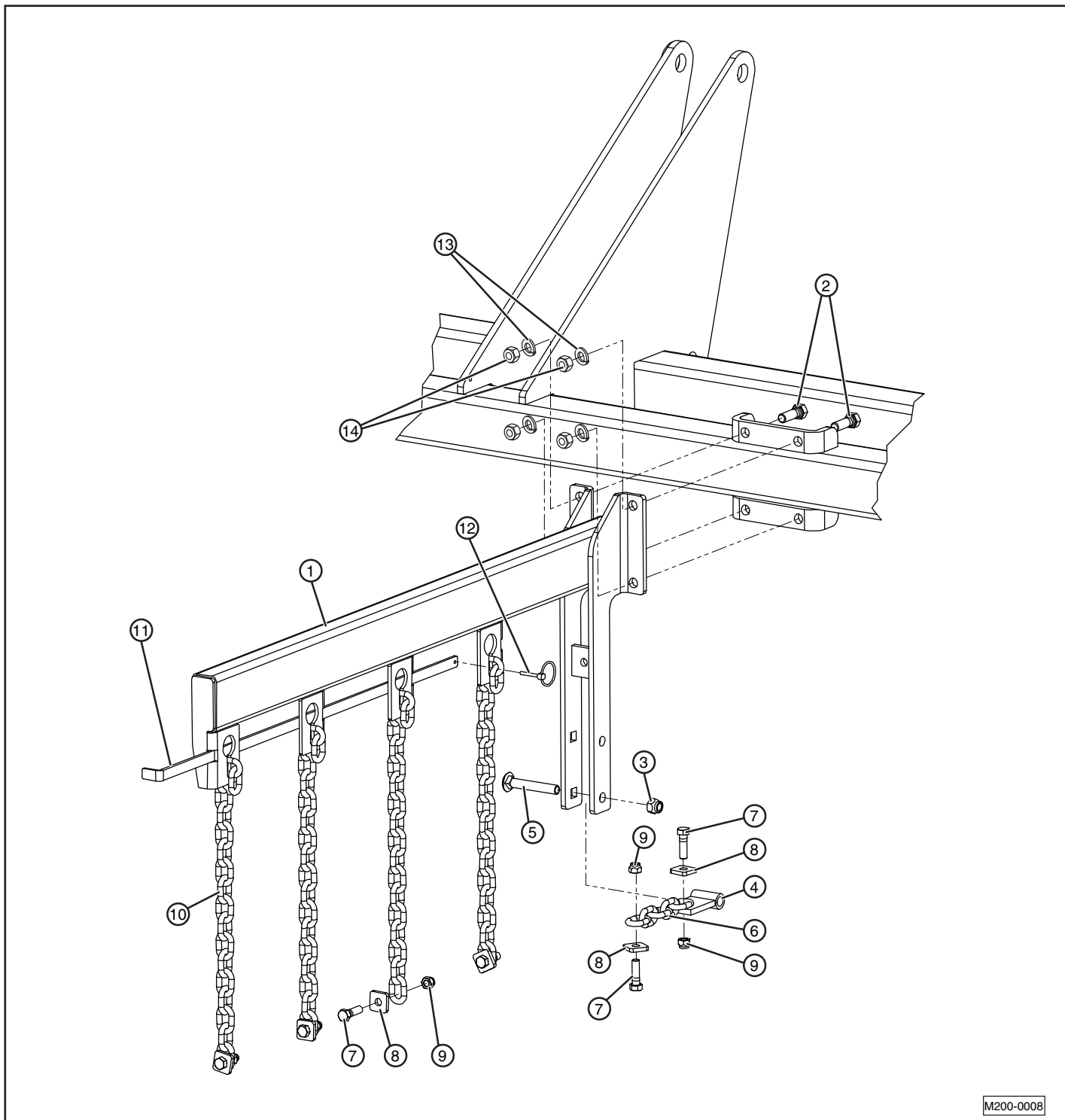

M200-0008

| Item | Part Number | Description | Qty. |
|------|-------------|--------------------------------|------|
| 1 | QT-1189 | LIFT ARM 4-BAR ASSY | 1 |
| 2 | BH-6320 | BOLT, 5/8-11 x 2 GD 5 | 4 |
| 3 | NLT-6311 | NUT, TOP LOCK 5/8-11 | 1 |
| 4 | FA-4105 | PULL POINT ASSY | 1 |
| 5 | BC-6340 | BOLT, CARRIAGE 5/8-11 x 4 GD 5 | 1 |
| 6 | CH-0805 | 3/8 x 5 CHAIN | 1 |
| 7 | BH-5018 | BOLT, 1/2-13 x 1-3/4 GD 5 | 6 |

| Item | Part Number | Description | Qty. |
|------|-------------|---------------------------------|------|
| 8 | HDD-016 | SQ WASHER 1/2 | 6 |
| 9 | NLT-5013 | NUT, TOP LOCK 1/2-13 | 6 |
| 10 | CH-0818 | 3/8 x 18 CHAIN | 4 |
| 11 | QT-1190 | LOCK BAR, LIFT CHAIN ASSY 4-BAR | 1 |
| 12 | PC-1913 | PIN, CLICK 3/16 x 1-9/16 | 1 |
| 13 | LW-0063 | LOCK WASHER, 5/8 | 4 |
| 14 | NH-6311 | NUT, HEX, 5/8-11 | 4 |

4-Bar Harrow Sections

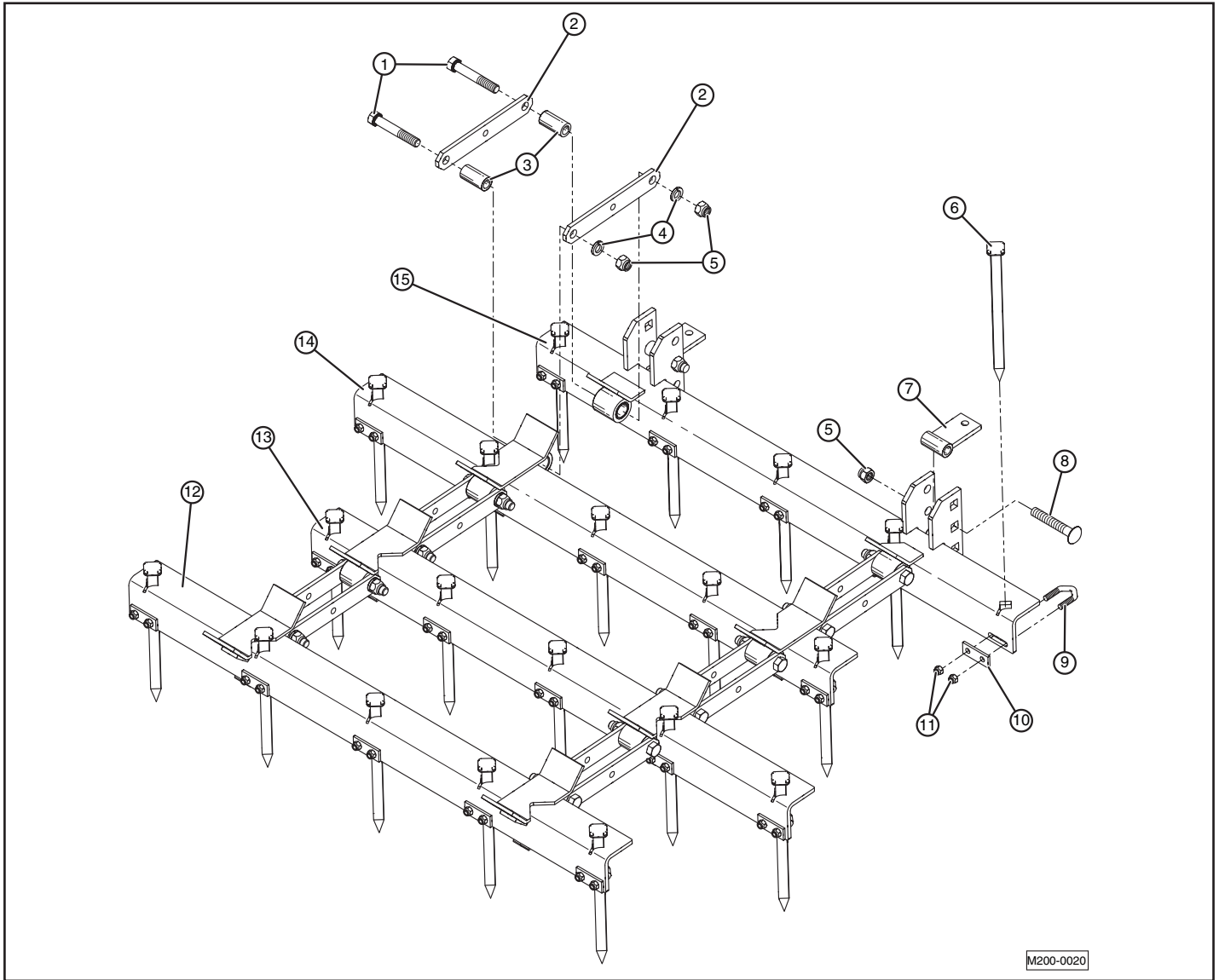

| Item | Part Number | Description | Qty. |
|------|-------------|--------------------------------|------|
| 1 | BH-6340 | 5/8-11 X 4 GRADE 5 BOLT | * |
| 2 | CT-105 | CT CONNECTOR LINK | * |
| 3 | CT-102 | INNER BUSHING | * |
| 4 | LW-0063 | 5/8 LOCK WASHER | * |
| 5 | NLT-6311 | 5/8-11 TOP LOCK NUT | * |
| 6 | CT-106 | SPIKE TOOTH | * |
| 7 | FA-4105 | PULL TAB | * |
| 8 | BC-6340 | 5/8-11 X 4 CARRIAGE BOLT | * |
| 9 | BV-3812 | 3/8 X 1 1/16 X 2 V-BEND U-BOLT | * |
| 10 | FA-4103 | 3/8 V-BOLT PLATE | * |
| 11 | NLT-3816 | 3/8-16 TOP LOCK NUT | * |
| 12 | CT-244 | #4 HARROW BAR (CT-40) 36" | * |
| | CT-254 | #4 HARROW BAR (CT-50) 47" | * |
| | CT-264 | #4 HARROW BAR (CT-60) 58" | * |
| | CT-274 | #4 HARROW BAR (CT-70) 69" | * |
| | CT-284 | #4 HARROW BAR (CT-80) 80" | * |

| Item | Part Number | Description | Qty. |
|------|-------------|---------------------------|------|
| 13 | CT-243 | #3 HARROW BAR (CT-40) 36" | * |
| | CT-253 | #3 HARROW BAR (CT-50) 47" | * |
| | CT-263 | #3 HARROW BAR (CT-60) 58" | * |
| | CT-273 | #3 HARROW BAR (CT-70) 69" | * |
| | CT-283 | #3 HARROW BAR (CT-80) 80" | * |
| 14 | CT-242 | #2 HARROW BAR (CT-40) 36" | * |
| | CT-252 | #2 HARROW BAR (CT-50) 47" | * |
| | CT-262 | #2 HARROW BAR (CT-60) 58" | * |
| | CT-272 | #2 HARROW BAR (CT-70) 69" | * |
| | CT-282 | #2 HARROW BAR (CT-80) 80" | * |
| 15 | CT-241 | #1 HARROW BAR (CT-40) 36" | * |
| | CT-251 | #1 HARROW BAR (CT-50) 47" | * |
| | CT-261 | #1 HARROW BAR (CT-60) 58" | * |
| | CT-271 | #1 HARROW BAR (CT-70) 69" | * |
| | CT-281 | #1 HARROW BAR (CT-80) 80" | * |

* Quantities vary.

3-Bar Harrow Lift Arm Assembly

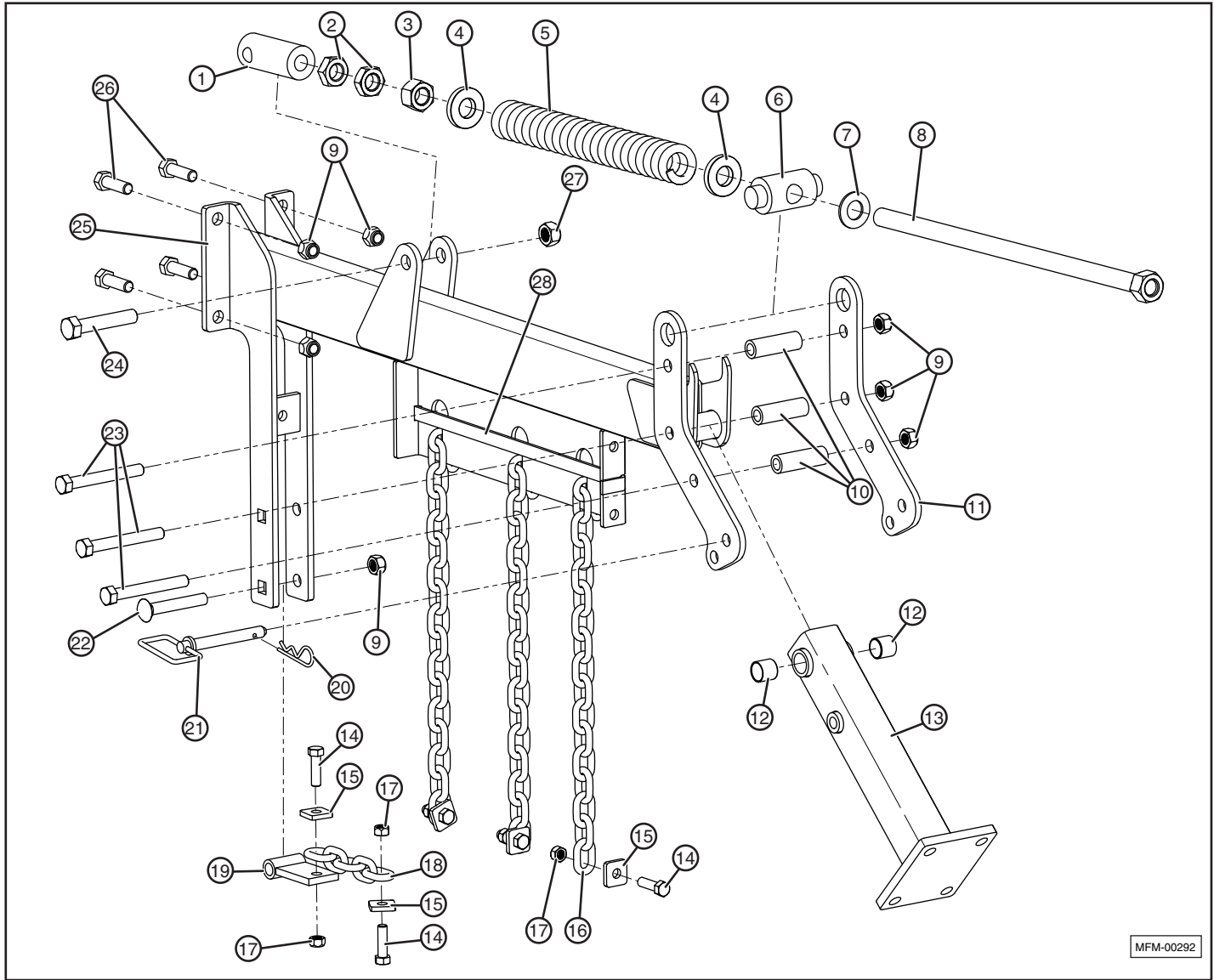

| Item | Part Number | Description | Qty. |
|------|-------------|---------------------------|------|
| 1 | 10713 | TUBE, ROUND, ADJUSTMENT | 1 |
| 2 | NHJ-1008 | NUT, JAM, 1-8 | 2 |
| 3 | NH-1008 | NUT, 1-8 | 1 |
| 4 | 10715 | WASHER, 1" | 2 |
| 5 | 10682 | SPRING, COMPRESSION | 1 |
| 6 | 10714 | TRUNNION | 1 |
| 7 | FW-0100 | WASHER, FLAT, 1" | 1 |
| 8 | 10959 | BOLT, SPECIAL | 1 |
| 9 | NLT-6311 | NUT, TOP LOCK, 5/8-11 | 3 |
| 10 | 10716 | TUBE, ROUND | 3 |
| 11 | 10718 | PLATE, PIVOT | 2 |
| 12 | 10710 | BUSHING, PLASTIC | 2 |
| 13 | 10678 | TUBE, PIVOT | 1 |
| 14 | BH-5018 | BOLT, HEX, 1/2-13 X 1-3/4 | 5 |

| Item | Part Number | Description | Qty. |
|------|-------------|---------------------------------|------|
| 15 | HDD-016 | WASHER, SQUARE, 1/2" | 5 |
| 16 | CH-0818 | CHAIN, 3/8", 18 LINK | 3 |
| 17 | NLT-5013 | NUT, TOP LOCK, 1/2-13 | 5 |
| 18 | CH-0805 | CHAIN, 3/8", 5 LINK | 1 |
| 19 | FA-4105 | PULL POINT ASSY | 1 |
| 20 | PB-0009 | PIN, BRIDGE, #9 | 1 |
| 21 | 11033 | PIN, HITCH, 7/8 X 6" | 1 |
| 22 | BC-6340 | BOLT, CARRIAGE 5/8-11 X 4 GD 5 | 1 |
| 23 | BH-6350 | BOLT, HEX, 5/8-11 X 5 GD 5 | 3 |
| 24 | BH-7540 | BOLT, HEX, 3/4-10 X 4 GD 5 | 1 |
| 25 | 10677 | ARM, LIFT, 3-BAR ASSY | 1 |
| 26 | BH-6320 | BOLT, 5/8-11 X 2 GD 5 | 1 |
| 27 | NLT-7510 | NUT, TOP LOCK, 3/4-10 | 1 |
| 28 | RD-5094 | LOCK BAR, LIFT CHAIN ASSY 3-BAR | 1 |

3-Bar Harrow Sections

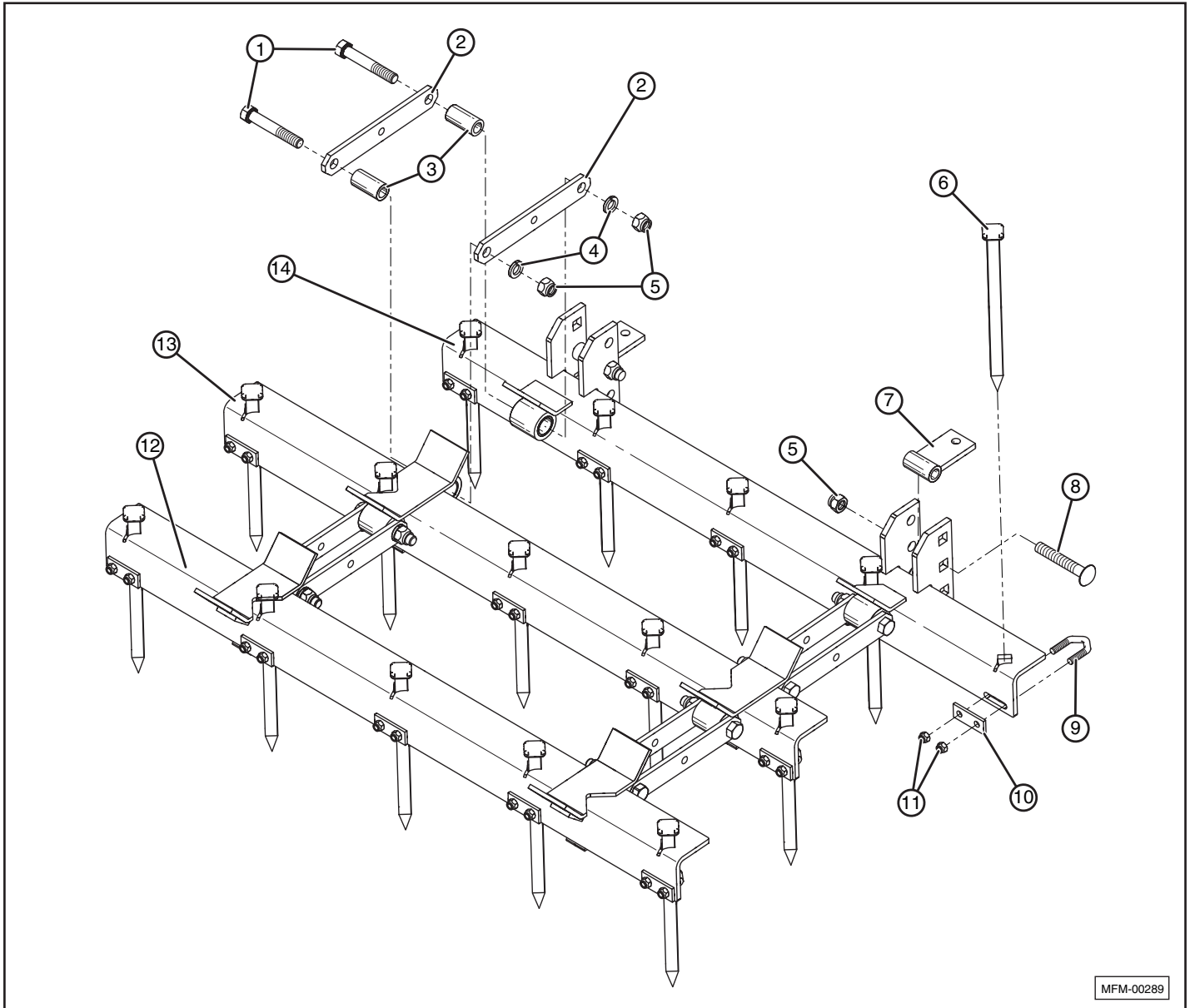

MFM-00289

| Item | Part Number | Description | Qty. |
|------|-------------|--------------------------------|------|
| 1 | BH-6340 | 5/8-11 X 4 GRADE 5 BOLT | * |
| 2 | CT-105 | CT CONNECTOR LINK | * |
| 3 | CT-102 | INNER BUSHING | * |
| 4 | LW-0063 | 5/8 LOCK WASHER | * |
| 5 | NLT-6311 | 5/8-11 TOP LOCK NUT | * |
| 6 | CT-106 | SPIKE TOOTH | * |
| 7 | FA-4105 | PULL TAB | * |
| 8 | BC-6340 | 5/8-11 X 4 CARRIAGE BOLT | * |
| 9 | BV-3812 | 3/8 X 1 1/16 X 2 V-BEND U-BOLT | * |
| 10 | FA-4103 | 3/8 V-BOLT PLATE | * |
| 11 | NLT-3816 | 3/8-16 TOP LOCK NUT | * |

| Item | Part Number | Description | Qty. |
|------|-------------|-----------------------------|------|
| 12 | CT-343 | #3 HARROW BAR (CT-40-3) 36" | * |
| | CT-353 | #3 HARROW BAR (CT-50-3) 47" | * |
| | CT-363 | #3 HARROW BAR (CT-60-3) 58" | * |
| | CT-373 | #3 HARROW BAR (CT-70-3) 69" | * |
| 13 | CT-342 | #2 HARROW BAR (CT-40-3) 36" | * |
| | CT-352 | #2 HARROW BAR (CT-50-3) 47" | * |
| | CT-362 | #2 HARROW BAR (CT-60-3) 58" | * |
| | CT-372 | #2 HARROW BAR (CT-70-3) 69" | * |
| 14 | CT-341 | #1 HARROW BAR (CT-40-3) 36" | * |
| | CT-351 | #1 HARROW BAR (CT-50-3) 47" | * |
| | CT-361 | #1 HARROW BAR (CT-60-3) 58" | * |
| | CT-371 | #1 HARROW BAR (CT-70-3) 69" | * |

* Quantities vary.

Rolling Basket Assembly

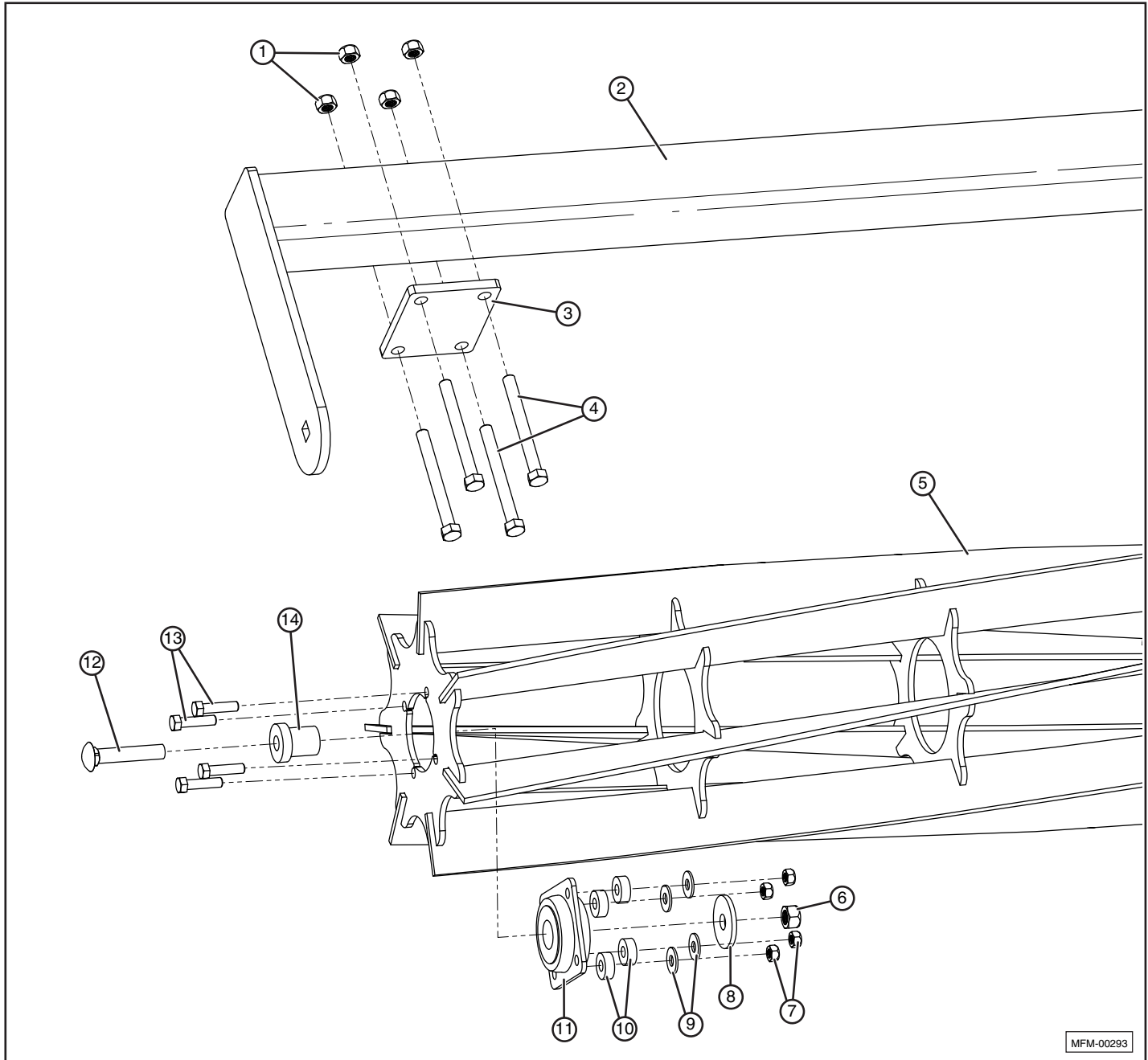

| Item | Part Number | Description | Qty. |
|------|-------------------------------------------|----------------------------------------------------------------------------------------------------------------------------------------------------|------|
| 1 | NLT-6311 | NUT, TOP LOCK 5/8-11 | 8 |
| 2 | 10581 10625 10630 11082 10579 | FRAME, ROLLING BASKET, 41" FRAME, ROLLING BASKET, 52" FRAME, ROLLING BASKET, 63" FRAME, ROLLING BASKET, 74" FRAME, ROLLING BASKET, 85" | 1 |
| 3 | 10721 | PLATE, CLAMP | 2 |
| 4 | BH-6360 | BOLT, HEX, 5/8-11 X 6" GD 5 | 8 |
| 5 | 10462 10627 10632 11084 10465 | ROLLING BASKET, 41" ROLLING BASKET, 52" ROLLING BASKET, 63" ROLLING BASKET, 74" ROLLING BASKET, 85" | 1 |
| 6 | NLT-7510 | NUT, TOP LOCK, 3/4-10 | 2 |
| 7 | NLT-5013 | NUT, TOP LOCK, 1/2-13 | 8 |

| Item | Part Number | Description | Qty. |
|------------------------------------------|-------------|--------------------------------------|------|
| 8 | SRB-1406 | WASHER, BEARING, 2-3/4 X 13/16 X 1/4 | 2 |
| 9 | FW-0050 | WASHER, FLAT, 1/2" | 8 |
| 10 | DRB-3828 | WASHER, RUBBER, BASKET BEARING | 8 |
| 11 | DRB-3826 | BEARING, FLANGED, 1-1/2, RND. | 2 |
| 12 | BC-7540 | BOLT, CARRIAGE, 3/4 X 4 | 2 |
| 13 | BH-5020 | BOLT, HEX, 1/2-13 X 2 | 8 |
| 14 | SRB-1408 | INSERT, BEARING, 2-1/8" | 1 |
| ROLLING BASKET, COMPLETE ASSEMBLY | | | |
| | 10583 | ROLLING BASKET ASSEMBLY, 41" | |
| | 10624 | ROLLING BASKET ASSEMBLY, 52" | |
| | 10629 | ROLLING BASKET ASSEMBLY, 63" | |
| | 11081 | ROLLING BASKET ASSEMBLY, 74" | |
| | 10580 | ROLLING BASKET ASSEMBLY, 85" | |

Main Lift Depth Stop Assembly

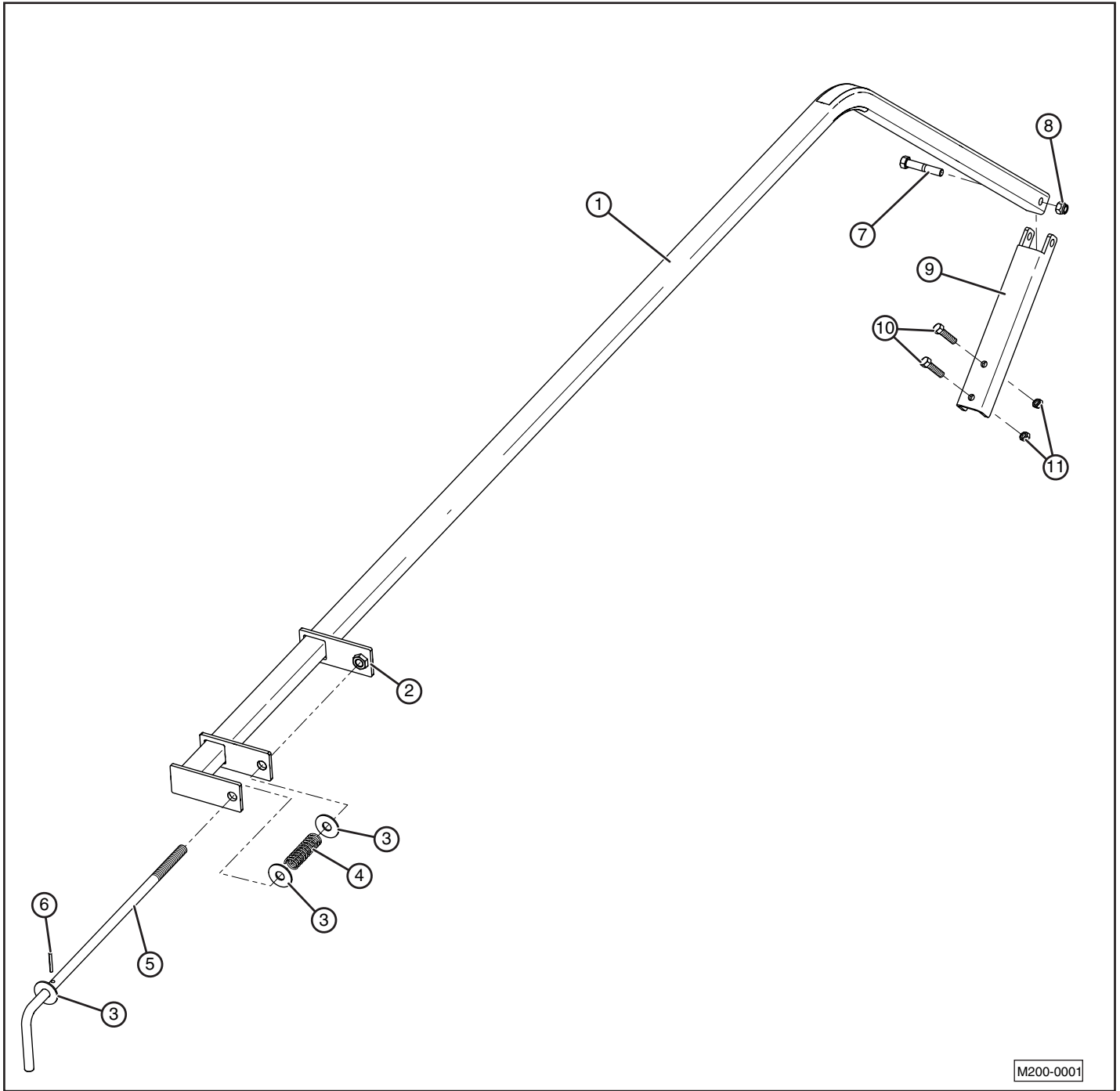

| Item | Part Number | Description | Qty. |
|------|-------------|-------------------------------|------|
| 1 | QT-1021 | HYD STOP TUBE | 1 |
| 2 | RD-4353 | HYD STOP PLATE | 1 |
| 3 | FW-0063 | WASHER, FLAT 5/8 | 3 |
| 4 | RD-4355 | SPRING, 1 x 3 | 1 |
| 5 | QT-1158 | HYD STOP CRANK QT | 1 |
| 6 | RD-4357 | PIN, SPRING ROLL 3/16 x 1-1/2 | 1 |

| Item | Part Number | Description | Qty. |
|------|-------------|-----------------------------|------|
| 7 | BH-5028 | BOLT, 1/2-13 x 2-3/4 GD 5 | 1 |
| 8 | NLT-5013 | NUT, TOP LOCK 1/2 - 13 | 1 |
| 9 | QT-1139 | HYDRAULIC STOP AXLE BRACKET | 1 |
| 10 | BH-3810 | BOLT, 3/8 - 16 x 1 GD 5 | 2 |
| 11 | NLT-3816 | NUT, TOP LOCK, 3/8 - 16 | 2 |

Lighting and Wiring Harness

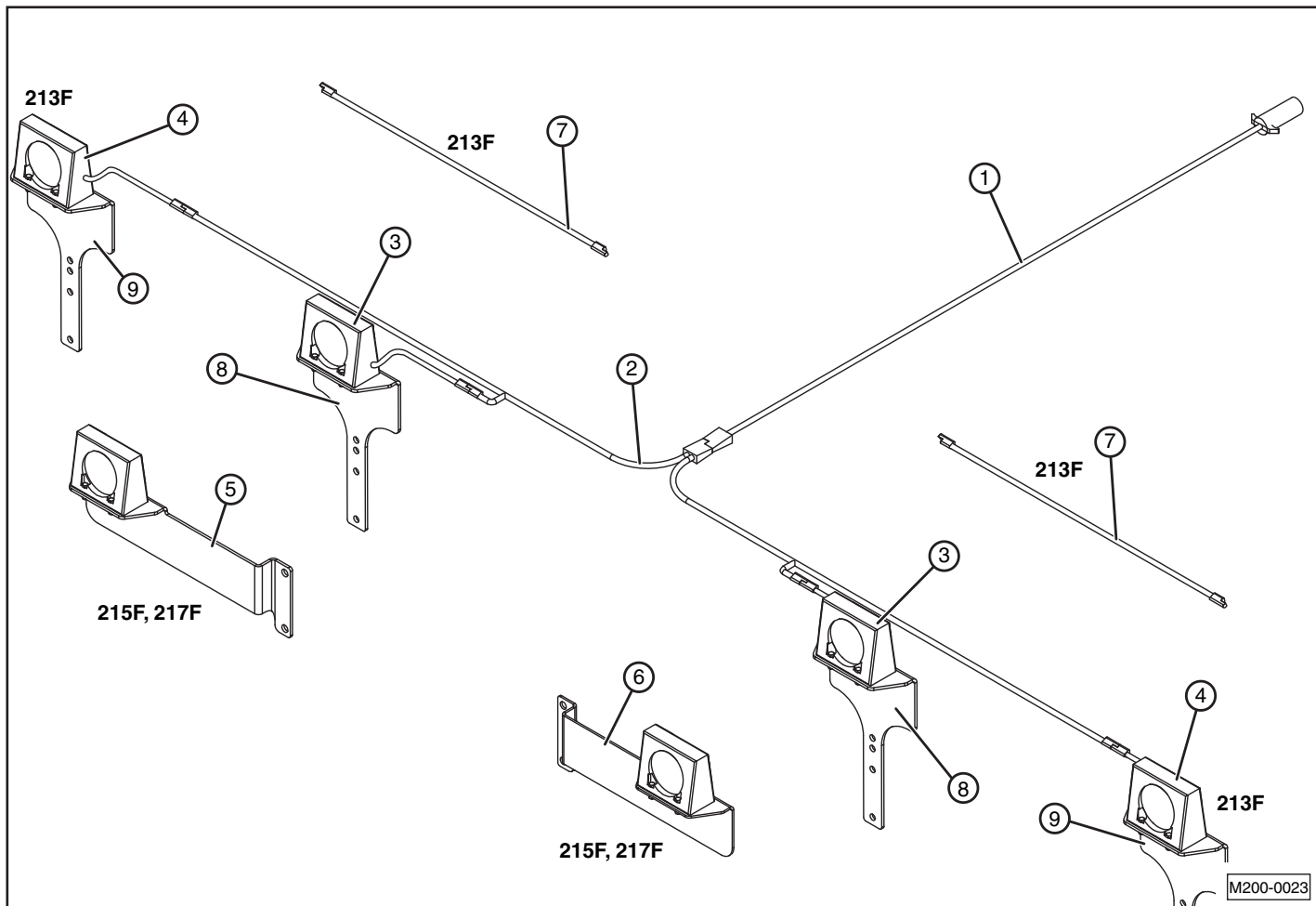

| Item | Part Number | Description | Qty. |
|------|-------------|-----------------------------------------------------|------|
| 1 | LB-1340 | LIGHT HARNESS, STRAIGHT 40' | 1 |
| 2 | LB-1620 | LIGHT HARNESS, WISHBONE SINGLE | 1 |
| 3 | LB-1107 | LIGHT, RED | 2 |
| 4 | LB-1106 | LIGHT, AMBER | 2 |
| 5 | 11126 | BRACKET, LIGHT, OUTER, LT (215F, 217F) | 1 |
| 6 | 11127 | BRACKET, LIGHT, OUTER, RT (215F, 217F) | 1 |
| 7 | LB-1505 | LIGHT HARNESS WISHBONE EXTENSION, 5' (QT-213F ONLY) | 2 |
| 8 | RD-5056 | BRACKET, LIGHT, SINGLE, INNER | 2 |
| 9 | 11128 | BRACKET, LIGHT, SINGLE, OUTER (207-213F) | 2 |

Wheel Cylinder Hydraulics

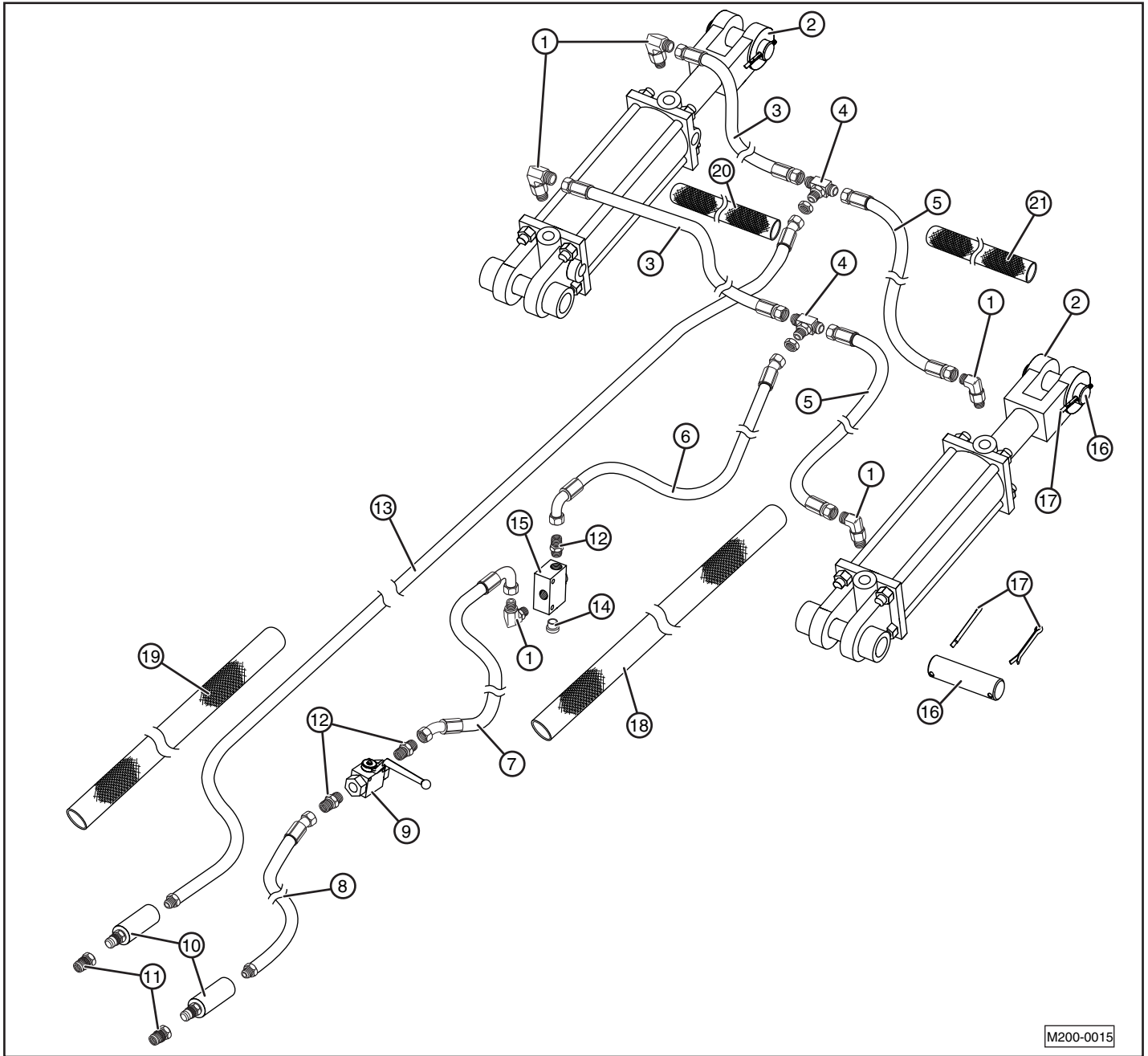

M200-0015

| Item | Part Number | Description | Qty. |
|------|----------------------|-----------------------------------------------------------------------|------|
| 1 | HYF-2220 | HYDRUALIC ELBOW, 1/2M-1/2M ORB | 6 |
| 2 | HYC-34012 | HYDRAULIC CYLINDER, 4 X 12 | 2 |
| 3 | HYH-2044 HYH-2065 | HYDRAULIC HOSE, (1/2 X 44) 207 HYDRAULIC HOSE, (1/2 X 65) 209-217F | 2 |
| 4 | HYF-1222 | HYDRAULIC TEE, 1/2M-1/2M-1/2M | 2 |
| 5 | HYH-2065 HYH-2085 | HYDRAULIC HOSE, (1/2 X 65) 207 HYDRAULIC HOSE, (1/2 X 85) 209-217F | 2 |
| 6 | HYH-1003 | HYDRAULIC HOSE, 1/2 X 107 | 1 |
| 7 | HYH-1004 | HYDRAULIC HOSE, 1/2 X 128 | 2 |
| 8 | HYH-2080 | HYDRAULIC HOSE, 1/2 X 80 | 2 |
| 9 | QT-1172 | 3/4 BALL VALVE | 1 |
| 10 | HYO-1212 | HYDRA-GRIP, YELLOW | 2 |

| Item | Part Number | Description | Qty. |
|------|-------------|------------------------------------|------|
| 11 | HYF-4002 | HYDRAULIC DISCONNECT, MALE | 2 |
| 12 | HYF-3220 | HYDRAULIC ADAPTER, 1/2M-1/2M ORB | 3 |
| 13 | HYH-3256 | HYDRAULIC HOSE, 1/2-1/2 PIPE X 256 | 1 |
| 14 | HYF-0150 | HYDRAULIC PLUG, 1/2 ORB | 1 |
| 15 | HYO-3021 | HYD STOP VALVE, RESTRICTED | 1 |
| 16 | HYO-2103 | CYLINDER CLEVIS PIN, 1 x 3 | 4 |
| 17 | CP-3620 | COTTER PIN, 3/16 x 2 | 8 |
| 18 | HYS-2003 | HYDRAULIC HOSE COVER, 25" | 1 |
| 19 | HYS-2002 | HYDRAULIC HOSE COVER, 85" | 1 |
| 20 | HYS-2005 | HYDRAULIC HOSE COVER, 42" | 1 |
| 21 | HYS-2006 | HYDRAULIC HOSE COVER, 60" | 1 |

Leveler Disk Hydraulics

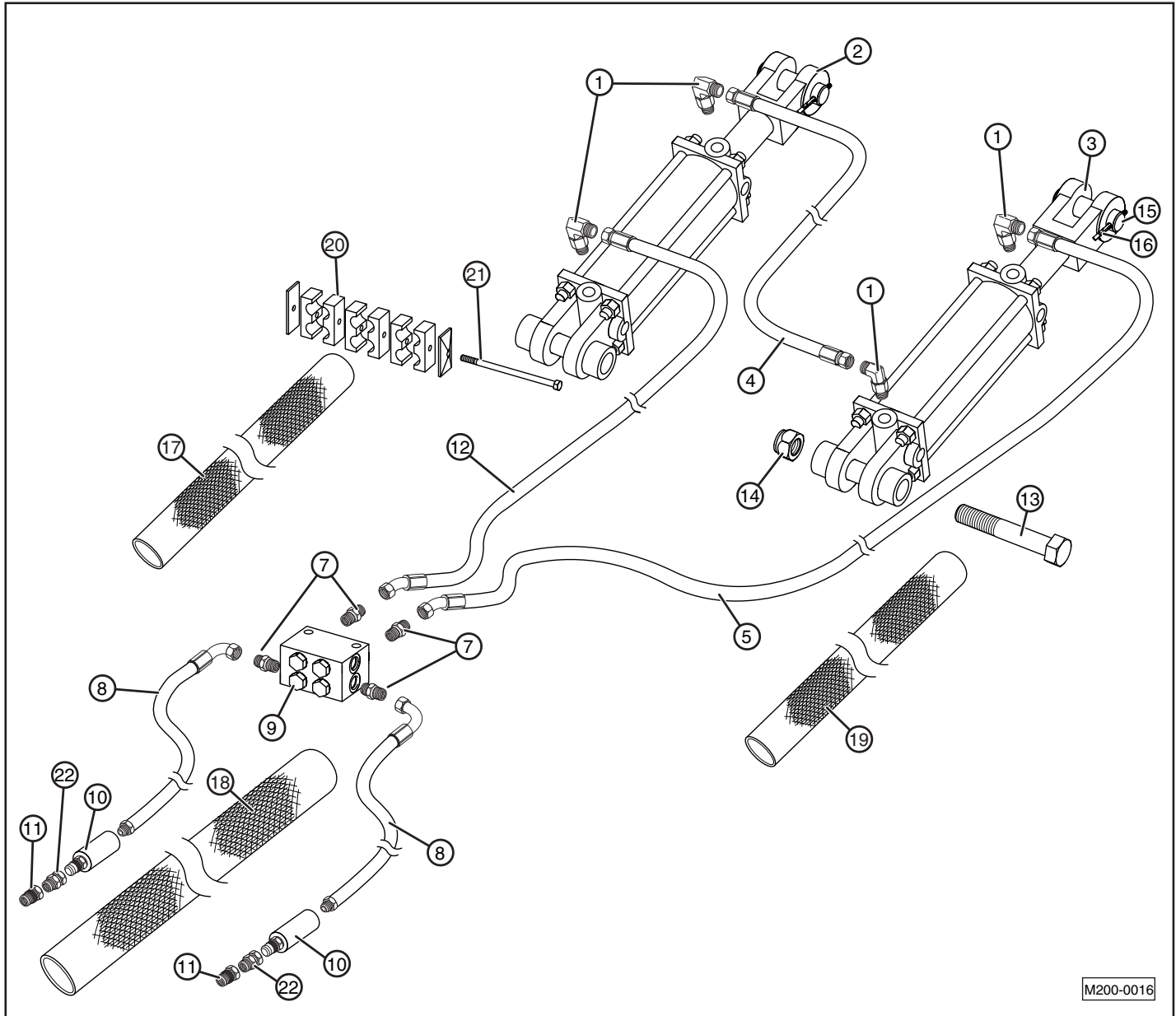

M200-0016

| Item | Part Number | Description | Qty. |
|------|----------------------------------|------------------------------------------------------------------------------------------------------------|------|
| 1 | HYF-2220 | HYDRAULIC ELBOW, 1/2M-1/2M ORB | 4 |
| 2 | HYR-4008 | HYDRAULIC CYLINDER, REPHASING, 4 x 8 ASAE | 1 |
| 3 | HYR-3808 | HYDRAULIC CYLINDER, REPHASING, 3 3/4 X 8 ASAE | 1 |
| 4 | HYH-2136 HYH-2167 | HYDRAULIC HOSE, 1/2 X 136" HYDRAULIC HOSE, 1/2 x 167" (215F) | 1 |
| 5 | HYH-1006 HYH-1018 HYH-1010 | HYDRAULIC HOSE, (1/2 X 255) 207-213 HYDRAULIC HOSE, (1/2 X 259) 213F HYDRAULIC HOSE, 1/2 x 265" 215F | 1 |
| 6 | — | — | — |
| 7 | HYF-3220 | HYDRAULIC ADAPTER, 1/2M-1/2M ORB | 4 |
| 8 | HYH-1007 | HYDRAULIC HOSE, 1/2 X 168" | 2 |
| 9 | QT-1058 | HYD LOCK VALVE | 2 |
| 10 | HYO-1210 | HYDRA-GRIP, RED | 2 |
| 11 | HYF-4002 | HYD DISCONNECT MALE | 2 |

| Item | Part Number | Description | Qty. |
|------|----------------------------------|------------------------------------------------------------------------------------------------------------|------|
| 12 | HYH-1005 HYH-1019 HYH-1020 | HYDRAULIC HOSE, (1/2 X 213) 207-213 HYDRAULIC HOSE, (1/2 X 217) 213F HYDRAULIC HOSE, 1/2 x 223" 215F | 1 |
| 13 | BHY-1070 | BOLT, 1 x 7 , GRADE 8 | 4 |
| 14 | NLT-1008 | NUT, TOP LOCK, 1-8 | 4 |
| 15 | HYO-2103 | CYLINDER CLEVIS PIN, 1 x 3 | 2 |
| 16 | CP-3620 | COTTER PIN, 3/16 x 2 | 4 |
| 17 | HYS-2005 | HYDRAULIC HOSE COVER, 42" | 1 |
| 18 | HYS-2001 | HYDRAULIC HOSE COVER, 110" | 2 |
| 19 | HYS-2007 | HYDRAULIC HOSE COVER, 70" | 1 |
| 20 | HYO-1202 | HYDRAULIC CLAMP BODY | 1 |
| 21 | BH-3415 | BOLT, HEX, 5/16 x 4-1/2" | 1 |
| 22 | HY-1301 | HYD RESTRICTOR, SWIVEL, 1/2Fp - 1/2 Mp, 1/16 | 2 |

Disk Gang Hydraulics

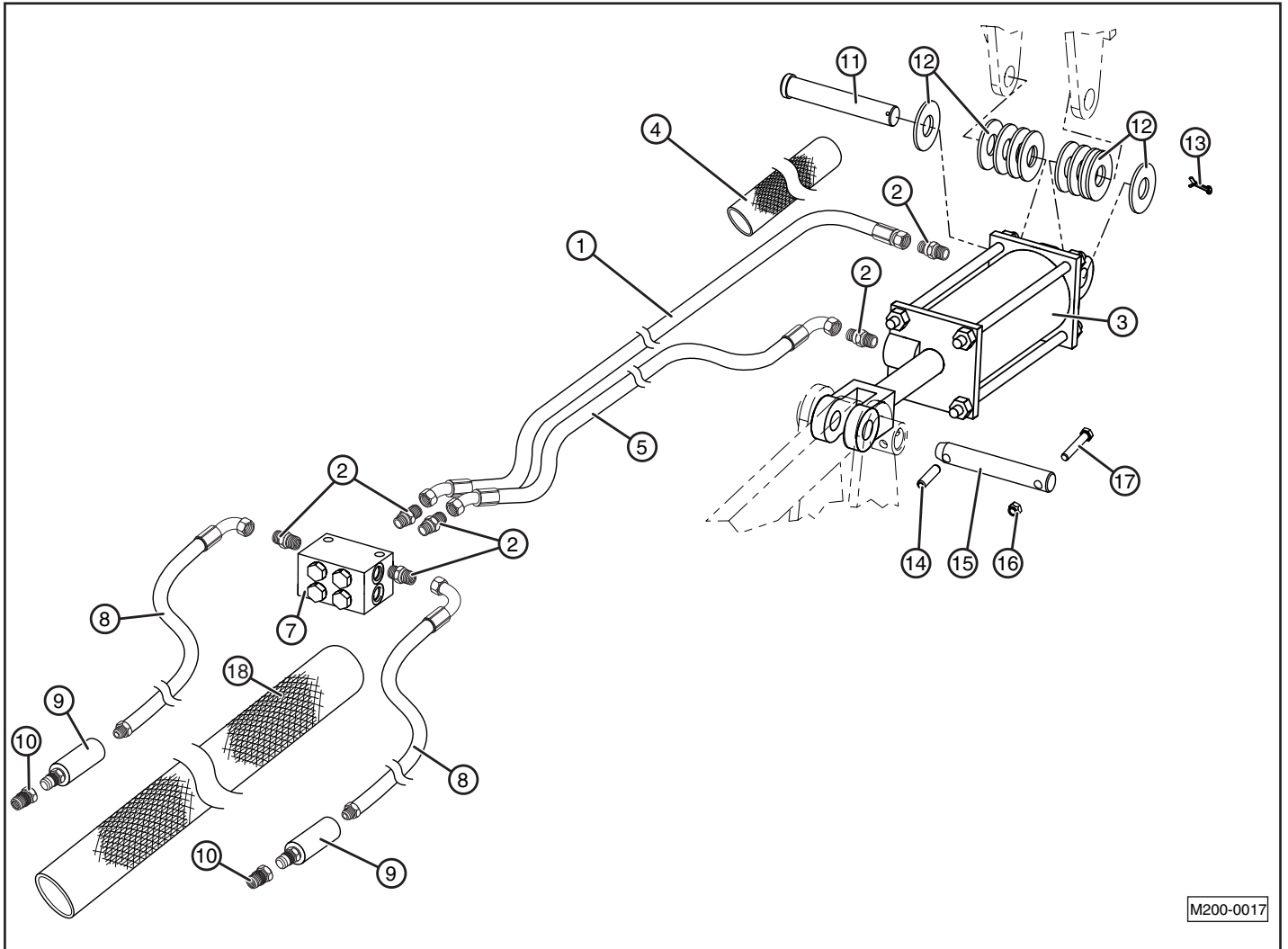

M200-0017

| Item | Part Number | Description | Qty. |
|------|-------------|------------------------------------|------|
| 1 | HYH-1001 | HYDRAULIC HOSE, 1/2 X 85 | 1 |
| 2 | HYF-3220 | HYDRAULIC ADAPTER, 1/2M - 1/2M ORB | 5 |
| 3 | HYA-34008 | HYDRAULIC CYLINDER, 4 X 8 ASAE | 1 |
| 4 | HYS-2004 | HYDRAULIC HOSE COVER, 12" | 1 |
| 5 | HYH-1002 | HYDRAULIC HOSE, 1/2 X 90 | 1 |
| 6 | — | — | — |
| 7 | QT-1058 | HYDRAULIC LOCK VALVE | 1 |
| 8 | HYH-1007 | HYDRAULIC HOSE, 1/2 X 168 | 2 |
| 9 | HYO-1211 | HYDRA-GRIP, GREEN | 2 |

| Item | Part Number | Description | Qty. |
|------|-------------|--------------------------------|------|
| 10 | HYF-4002 | HYD DISCONNECT MALE | 2 |
| 11 | CL-1006 | CLEVIS PIN, 1 x 6 | 1 |
| 12 | FW-0100 | FLAT WASHER, 1" | 10 |
| 13 | CP-3620 | COTTER , 3/16 x 2 | 1 |
| 14 | QT-1149 | PIN, SPRING ROLL, 7/16 x 1-3/4 | 1 |
| 15 | QT-1148 | DISK HITCH PIVOT PIN REAR | 1 |
| 16 | NLT-3816 | NUT, TOP LOCK 3/8-16 | 1 |
| 17 | BH-3823 | BOLT, 3/8-16 x 2-1/4 GD 5 | 1 |
| 18 | HYS-2001 | HYDRAULIC HOSE COVER, 110" | 1 |

Hydraulic Diagram for QT-213F Wing Fold Cylinders

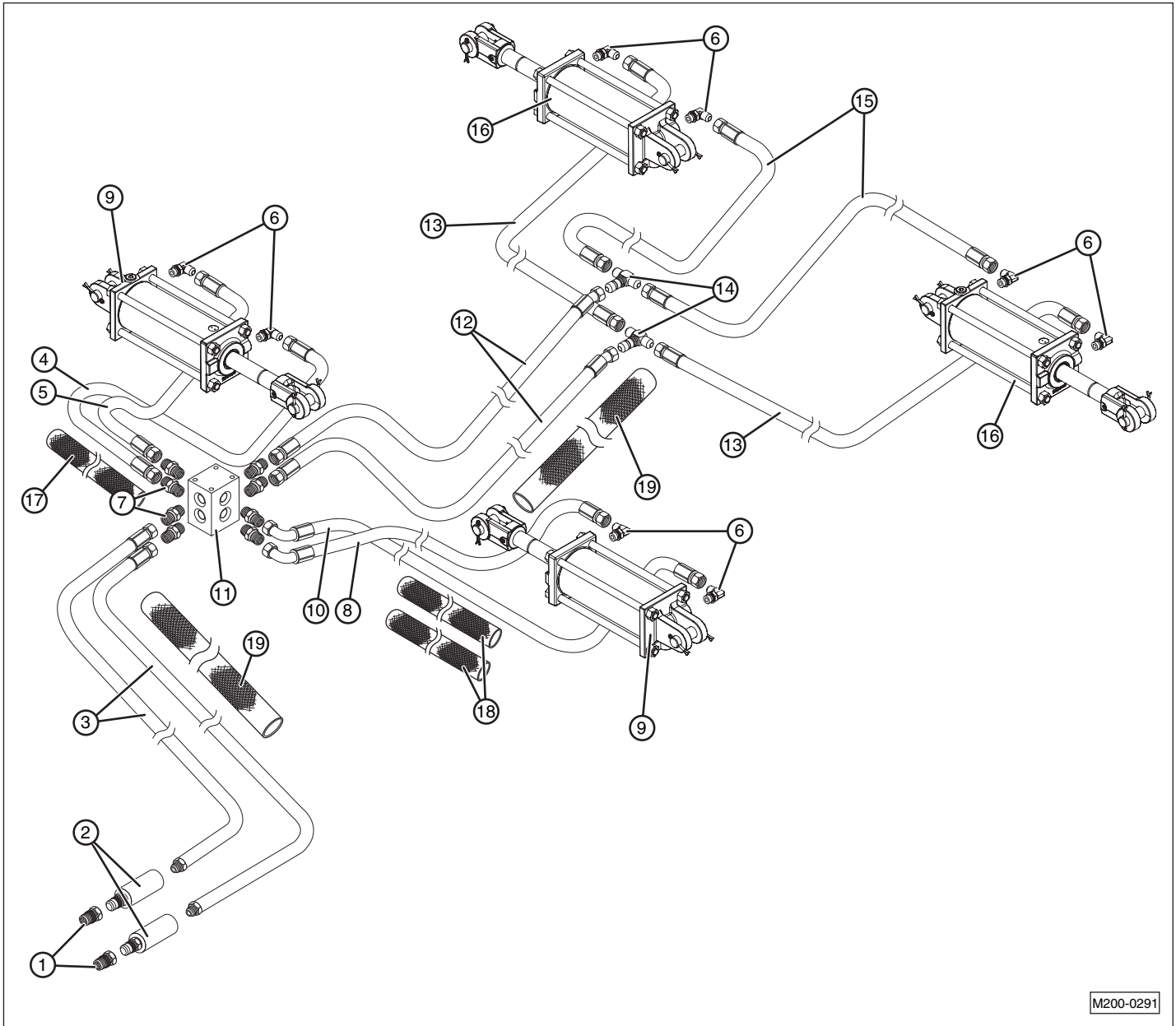

M200-0291

| Item | Part Number | Description | Qty. |
|------|-------------|----------------------------------------------|------|
| 1 | HYF-4002 | HYDRAULIC DISCONNECT, MALE | 2 |
| 2 | HYO-1211 | HYDRA-GRIP | 2 |
| 3 | HYH-4256 | HYDRAULIC HOSE 1/2 X 256 | 2 |
| 4 | HYH-2094 | HYDRAULIC HOSE 1/2 X 94 | 1 |
| 5 | HYH-2080 | HYDRAULIC HOSE 1/2 X 80 | 1 |
| 6 | HYF-2221 | HYDRAULIC ELBOW, 1/2M - 1/2M ORB, RESTRICTOR | 8 |
| 7 | HYF-3220 | HYDRAULIC ADAPTER, 1/2M - 1/2M ORB | 8 |
| 8 | HYH-1022 | HYDRAULIC HOSE 1/2 X 136 | 1 |
| 9 | HYA-33008 | CYLINDER, 3 X 8 ASAE | 2 |

| Item | Part Number | Description | Qty. |
|------|-------------|-------------------------------|------|
| 10 | HYH-1021 | HYDRAULIC HOSE 1/2 X 122 | 1 |
| 11 | HYO-3022 | HYDRAULIC MANIFOLD, 4-WAY | 1 |
| 12 | HYH-1023 | HYDRAULIC HOSE 1/2 X 244 | 2 |
| 13 | HYH-2042 | HYDRAULIC HOSE 1/2 X 42 | 2 |
| 14 | HYF-1222 | HYDRAULIC TEE, 1/2M-1/2M-1/2M | 2 |
| 15 | HYH-2024 | HYDRAULIC HOSE 1/2 X 24 | 2 |
| 16 | HYC-33014 | CYLINDER, 3 X 14 | 2 |
| 17 | HYS-2007 | HYDRAULIC HOSE COVER, 70" | 1 |
| 18 | HYS-2005 | HYDRAULIC HOSE COVER, 42" | 2 |
| 19 | HYS-2008 | HYDRAULIC HOSE COVER, 134" | 2 |

Hydraulic Diagram for QT-215F and QT-217F Wing Fold Cylinders

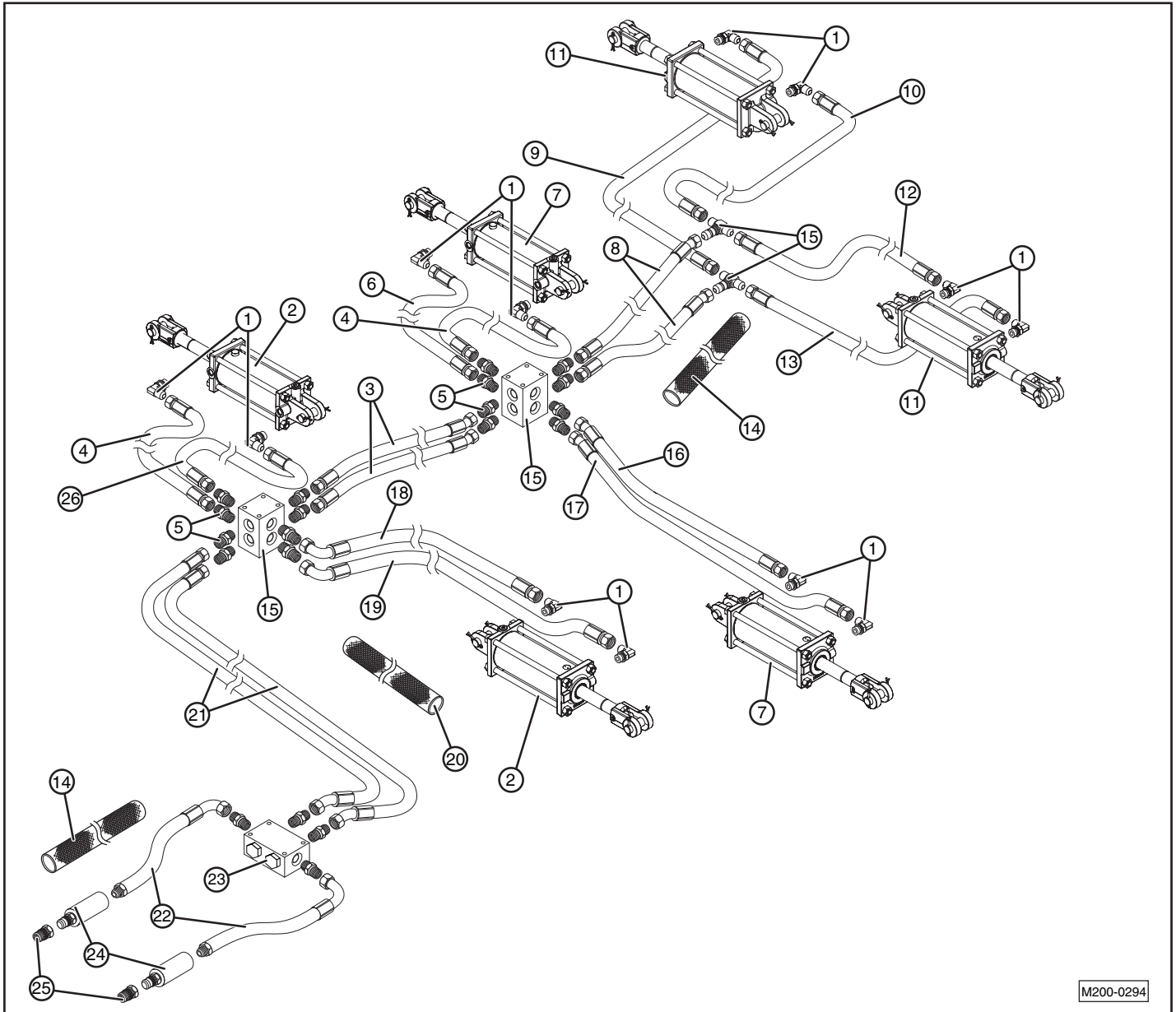

M200-0294

| Item | Part Number | Description | Qty. |
|------|-------------|---------------------------------------------------------------------------|------|
| 1 | HYF-2221 | HYDRAULIC ELBOW, 1/2M - 1/2M ORB, RESTRICTOR (ON ALL WING FOLD CYLINDERS) | 12 |
| 2 | HYC-34014 | CYLINDER, 4 X 14 | 2 |
| 3 | HYH-1015 | HYDRAULIC HOSE 1/2 X 92 | 2 |
| 4 | HYH-2042 | HYDRAULIC HOSE 1/2 X 42 | 1 |
| 5 | HYF-3220 | HYDRAULIC ADAPTER, 1/2M - 1/2M ORB (ON ALL MANIFOLD PORTS) | 20 |
| 6 | HYH-2060 | HYDRAULIC HOSE 1/2 X 60 | 1 |
| 7 | HYA-33516 | CYLINDER, 3 1/2 X 16, ASAE | 2 |
| 8 | HYH-2122 | HYDRAULIC HOSE 1/2 X 122 | 2 |
| 9 | HYH-2040 | HYDRAULIC HOSE 1/2 X 40 | 1 |
| 10 | HYH-2022 | HYDRAULIC HOSE 1/2 X 22 | 1 |
| 11 | HYC-33014 | CYLINDER, 3 X 14 | 2 |
| 12 | HYH-2085 | HYDRAULIC HOSE 1/2 X 85 | 1 |

| Item | Part Number | Description | Qty. |
|------|-------------|------------------------------|------|
| 13 | HYH-2101 | HYDRAULIC HOSE 1/2 X 101 | 1 |
| 14 | HYS-2001 | HYDRAULIC HOSE COVER 110" | 1 |
| 15 | HYO-3022 | HYDRAULIC MANIFOLD, 4-WAY | 2 |
| 16 | HYH-1017 | HYDRAULIC HOSE 1/2 X 66 | 1 |
| 17 | HYH-1016 | HYDRAULIC HOSE 1/2 X 85 | 1 |
| 18 | HYH-1012 | HYDRAULIC HOSE 1/2 X 69 | 1 |
| 19 | HYH-1013 | HYDRAULIC HOSE 1/2 X 86 | 1 |
| 20 | HYS-2005 | HYDRAULIC HOSE COVER 42" | 1 |
| 21 | HYH-1014 | HYDRAULIC HOSE 1/2 X 76 | 2 |
| 22 | HYH-1007 | HYDRAULIC HOSE 1/2 X 168 | 2 |
| 23 | QT-1302 | HYDRAULIC LOCK VALVE, SINGLE | 1 |
| 24 | HYO-1213 | HYDRA-GRIP (BLACK) | 2 |
| 25 | HYF-4002 | HYDRAULIC DISCONNECT, MALE | 2 |
| 26 | HYH-2032 | HYDRAULIC HOSE 1/2 X 32 | 1 |

Chisel Shank Layout Diagram

QT-207 - Shank Frame

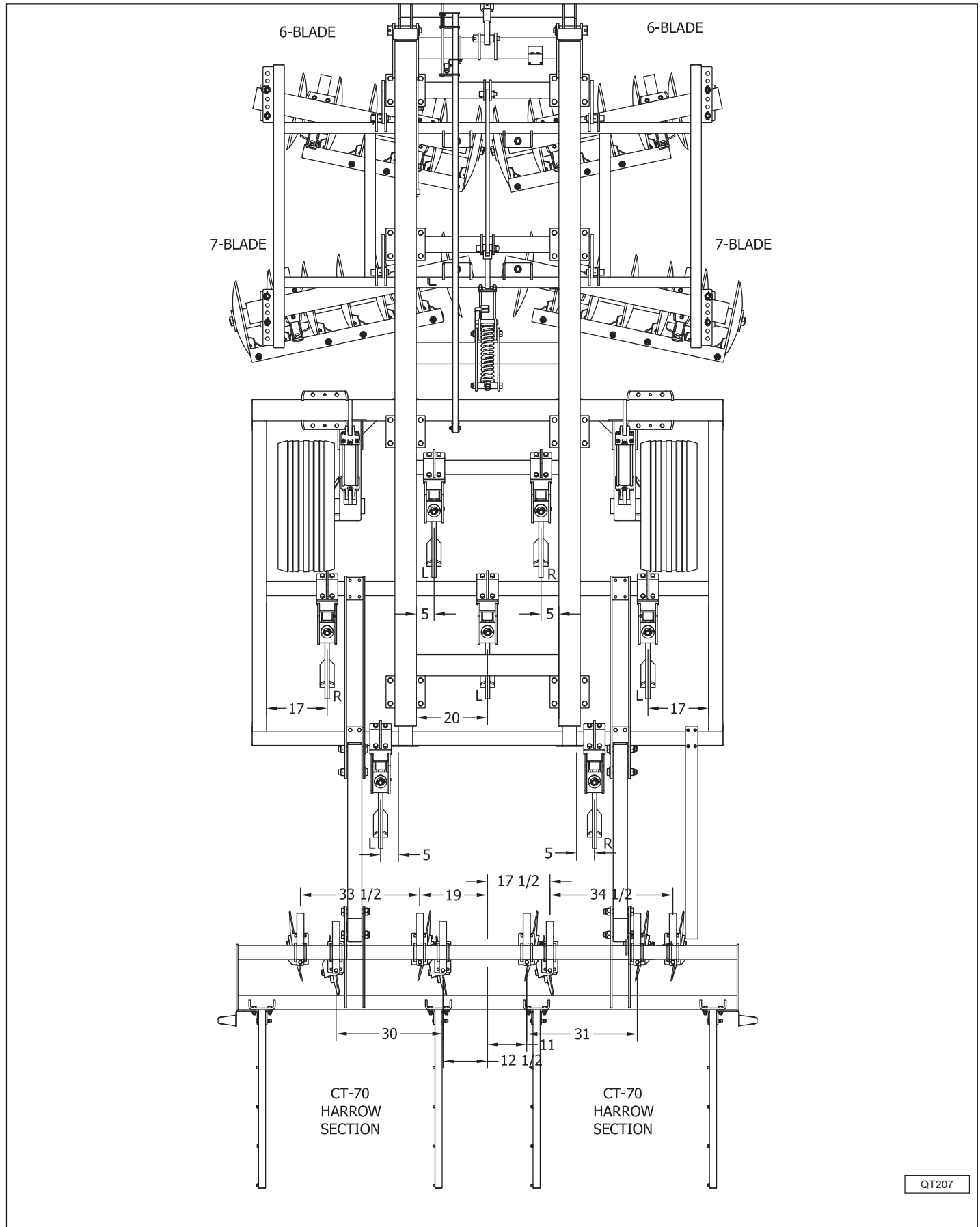

QT-209 - Shank Frame

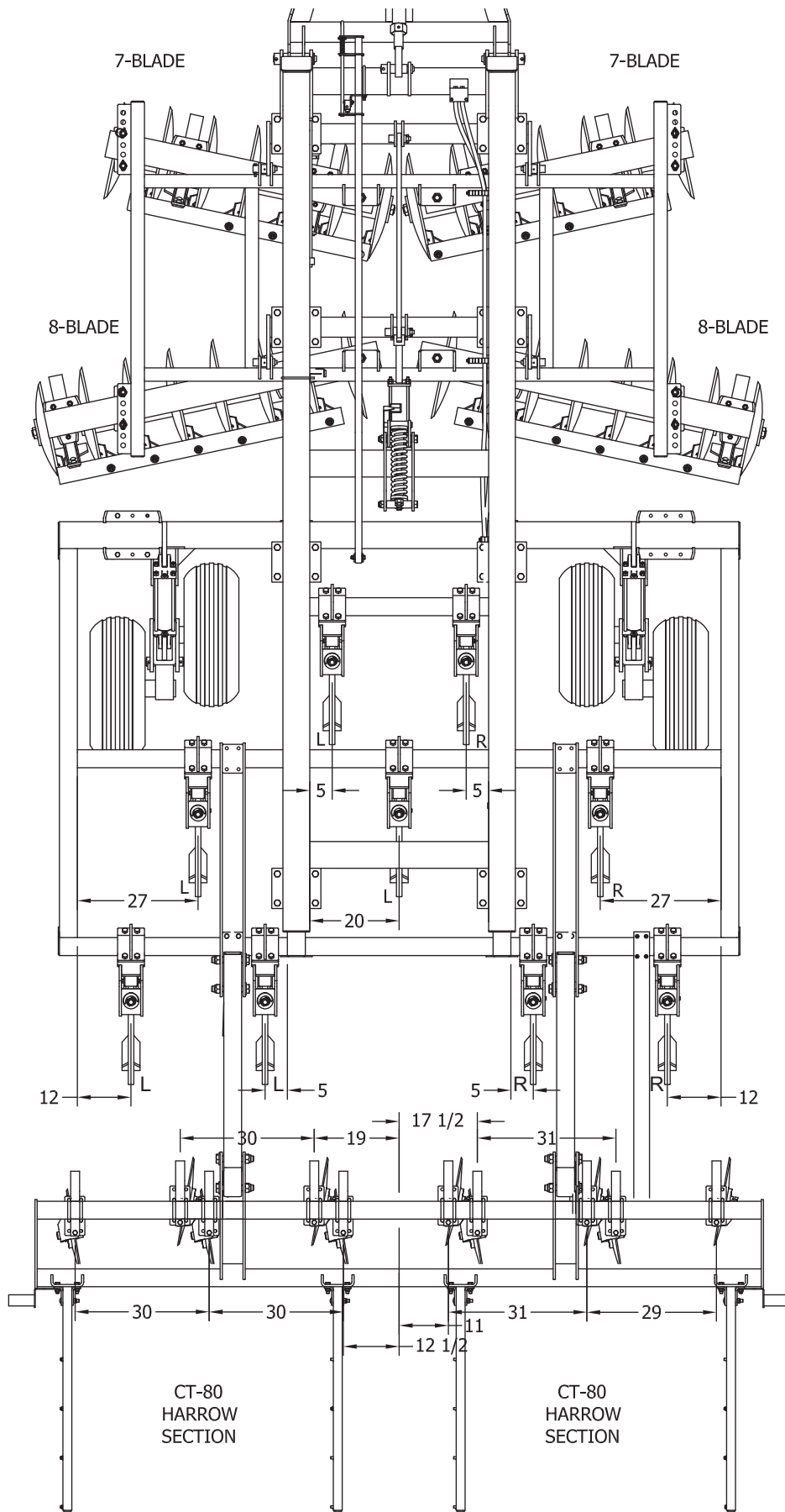

QT209

QT-211 - Shank Frame

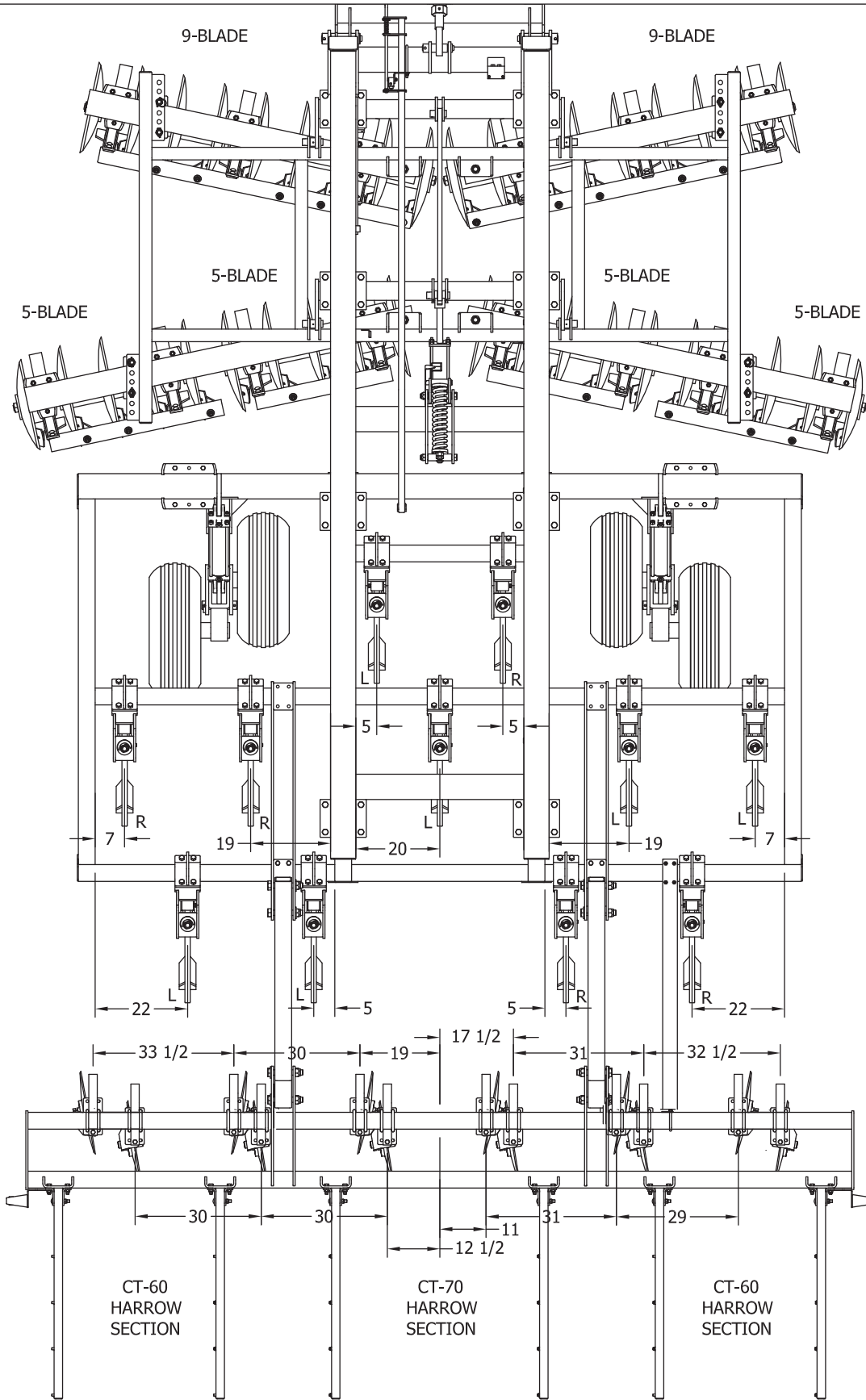

QT211

QT-213 - Shank Frame

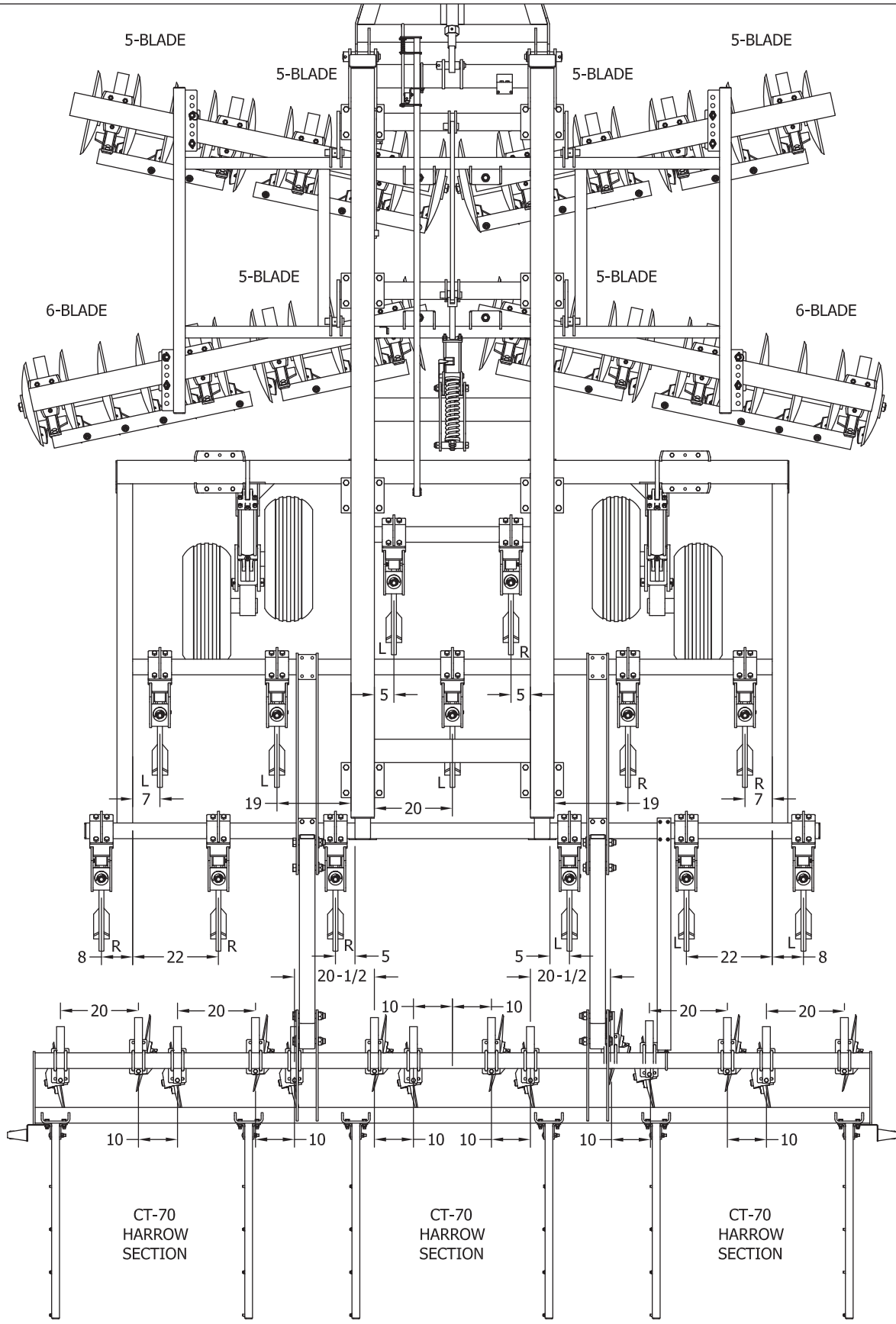

QT213

QT-213F - Shank Frame

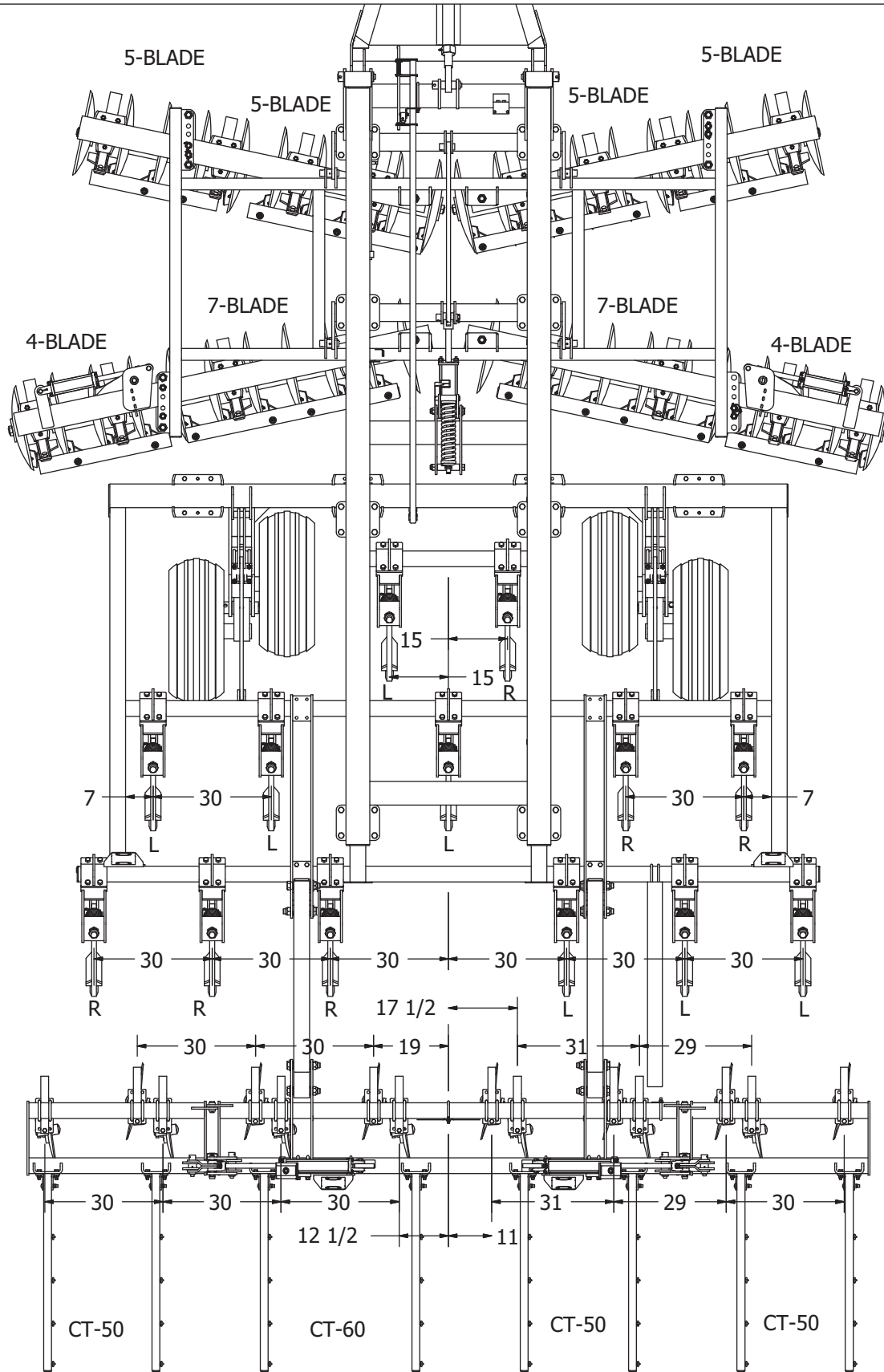

QT213F

QT-215F - Shank Frame

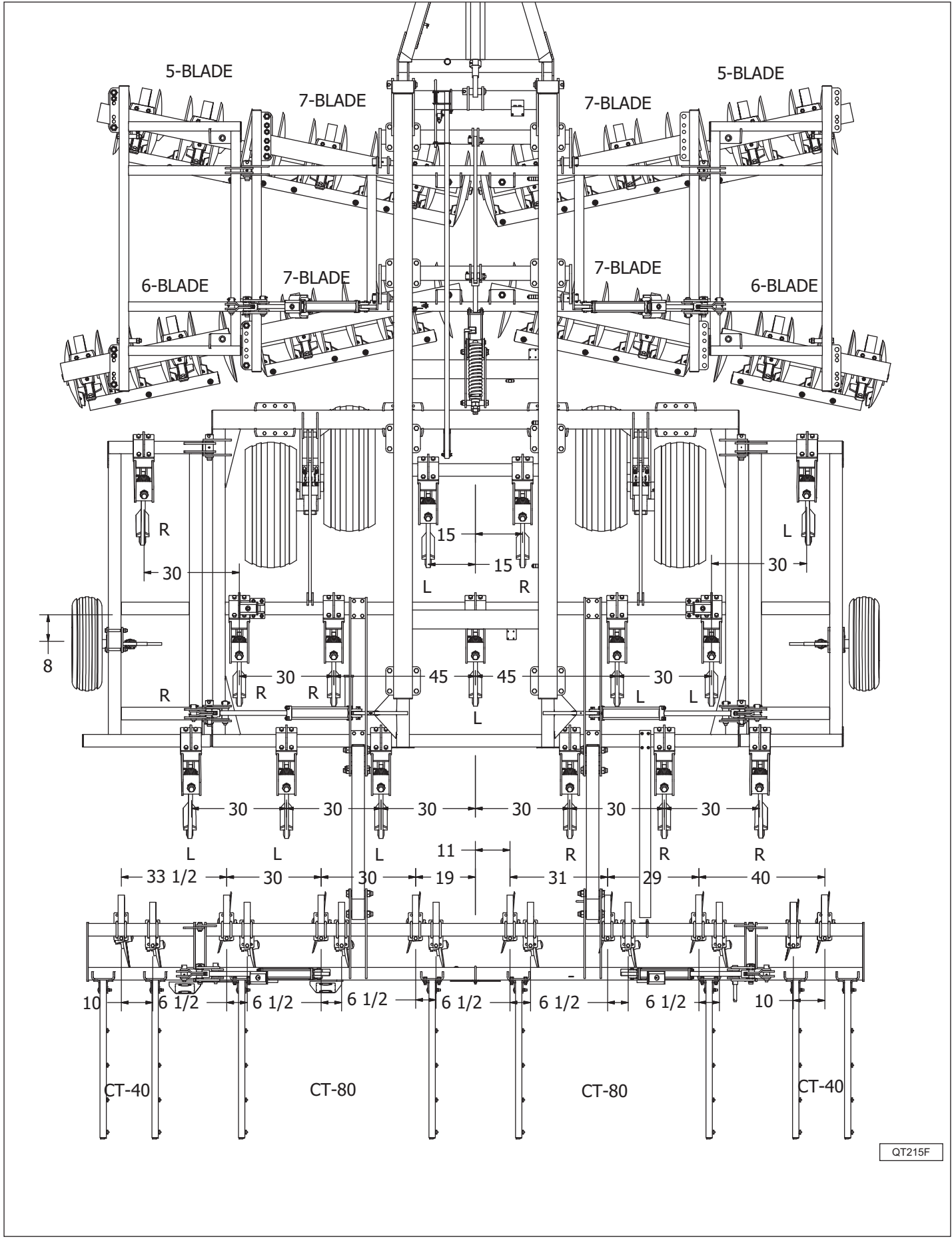

QT-217F - Shank Frame

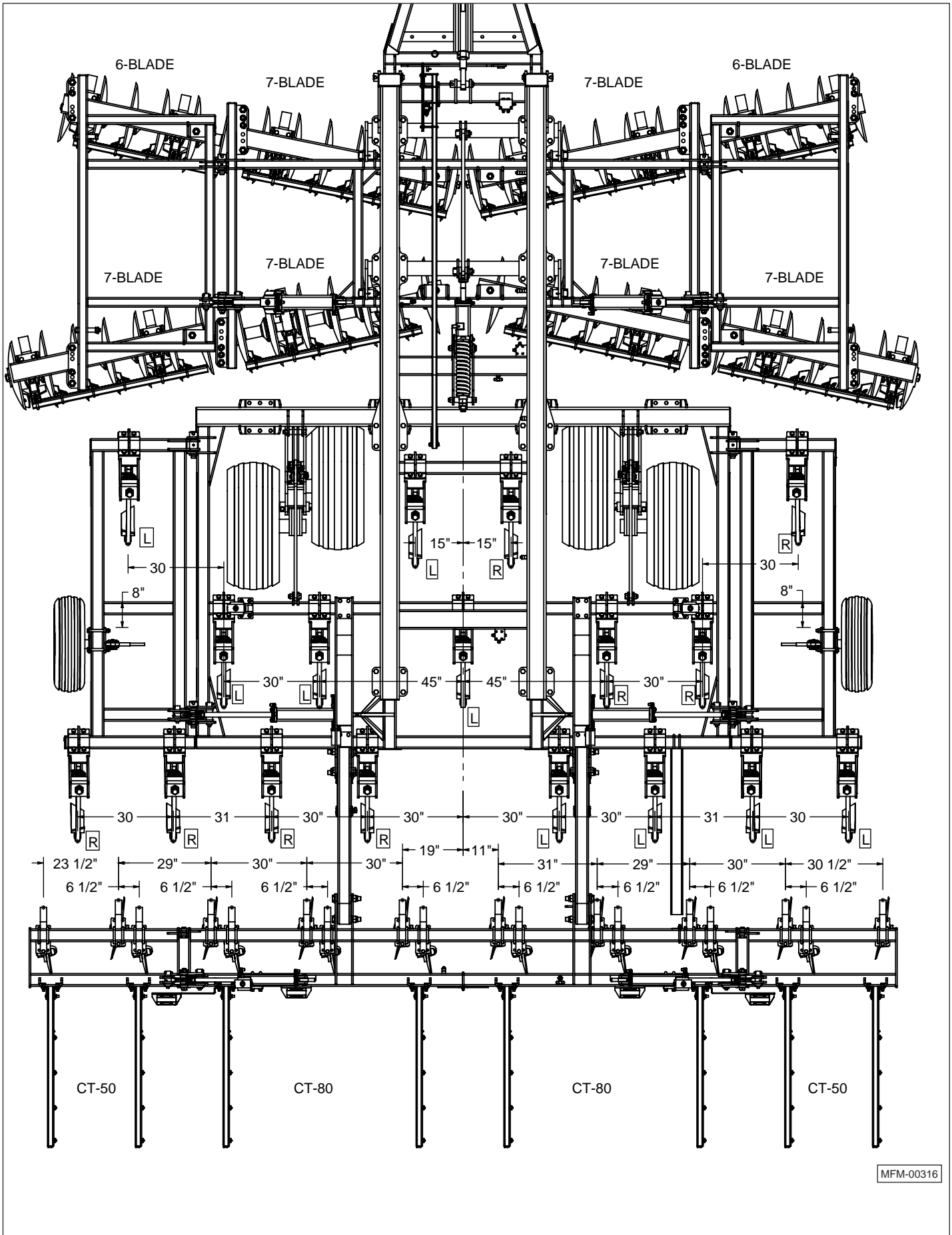

Rolling Basket Layout Diagram

QT-207 - Rolling Basket Layout

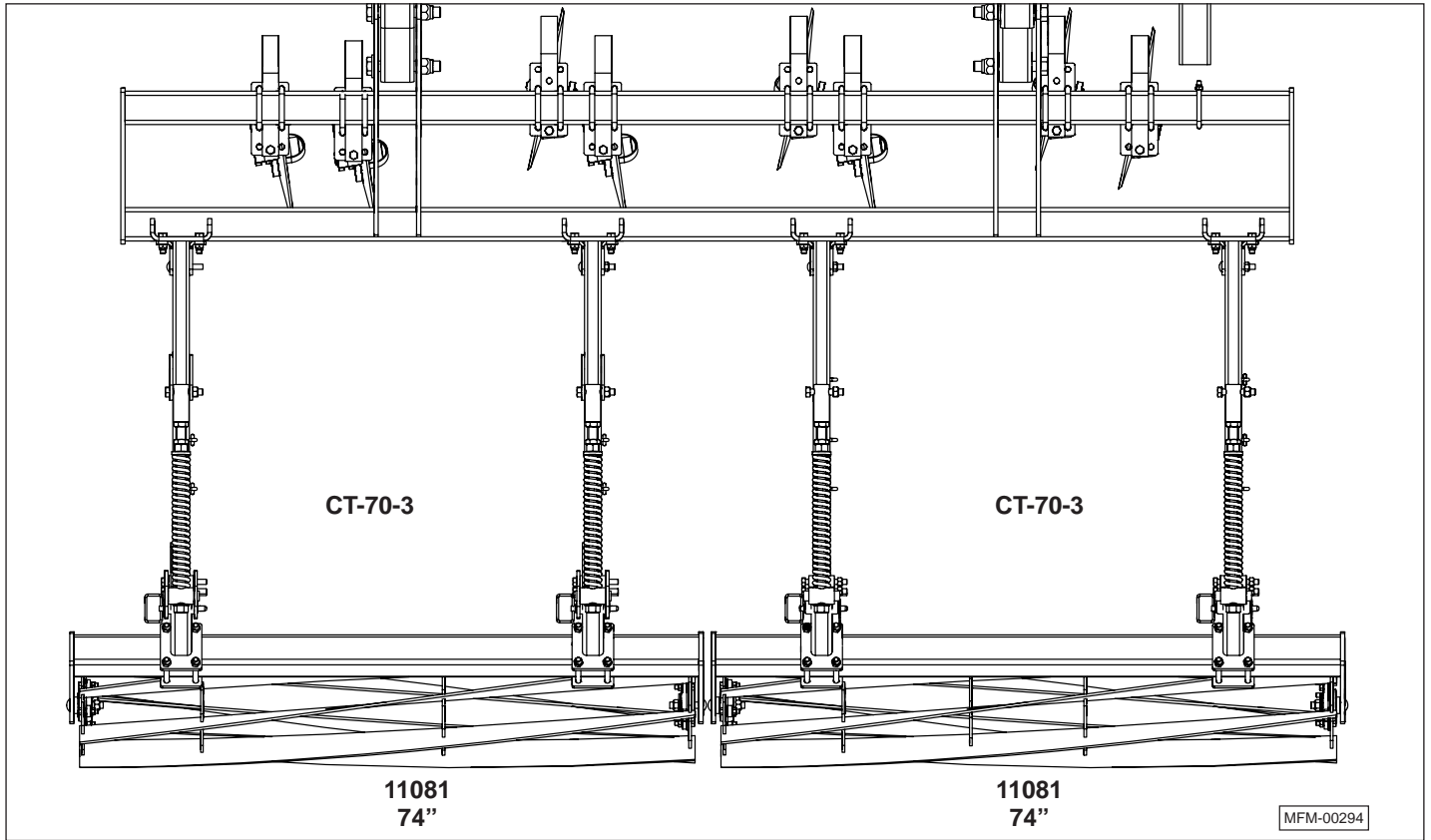

QT-209 - Rolling Basket Layout

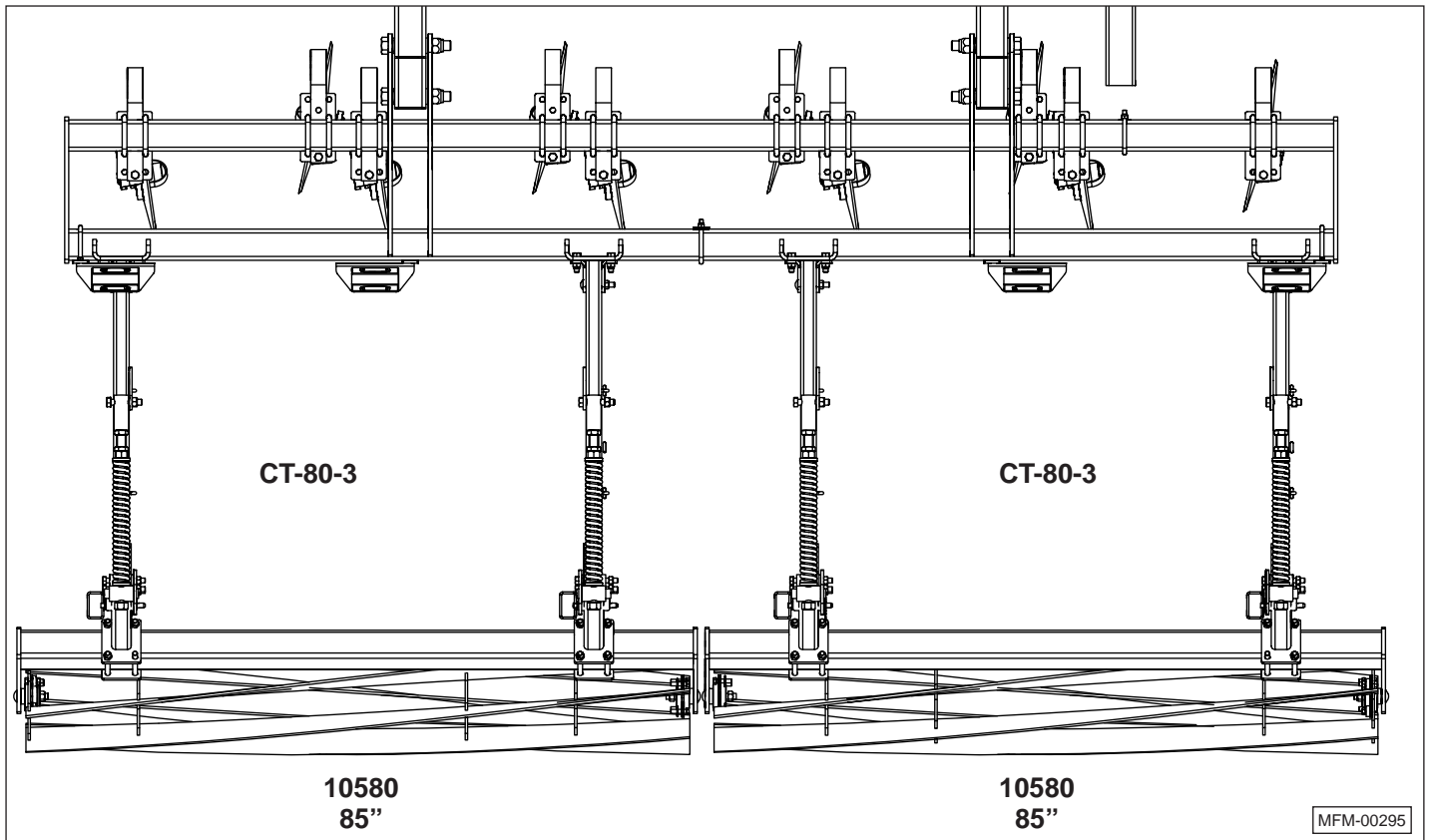

QT-211 - Rolling Basket Layout

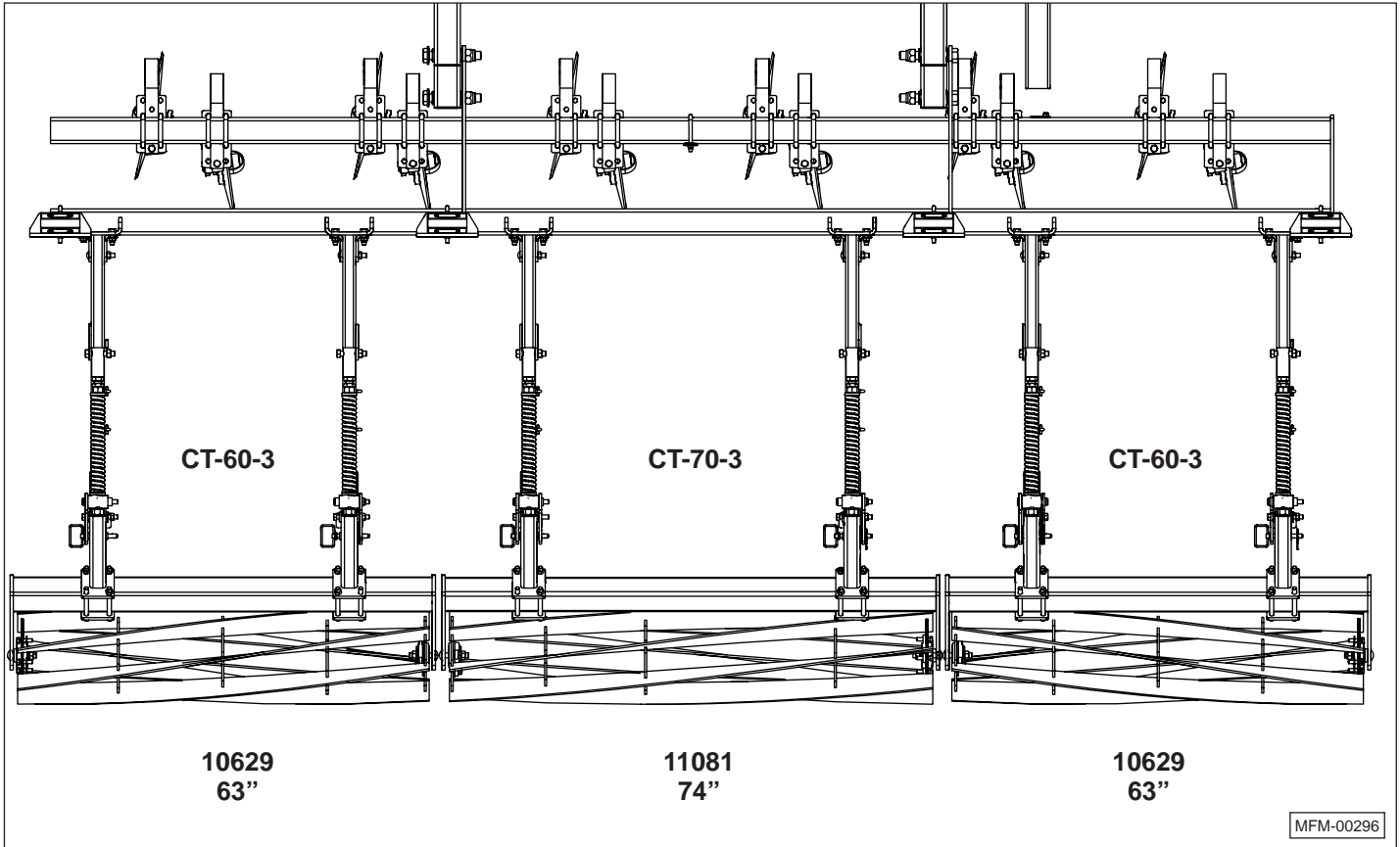

QT-213F - Rolling Basket Layout

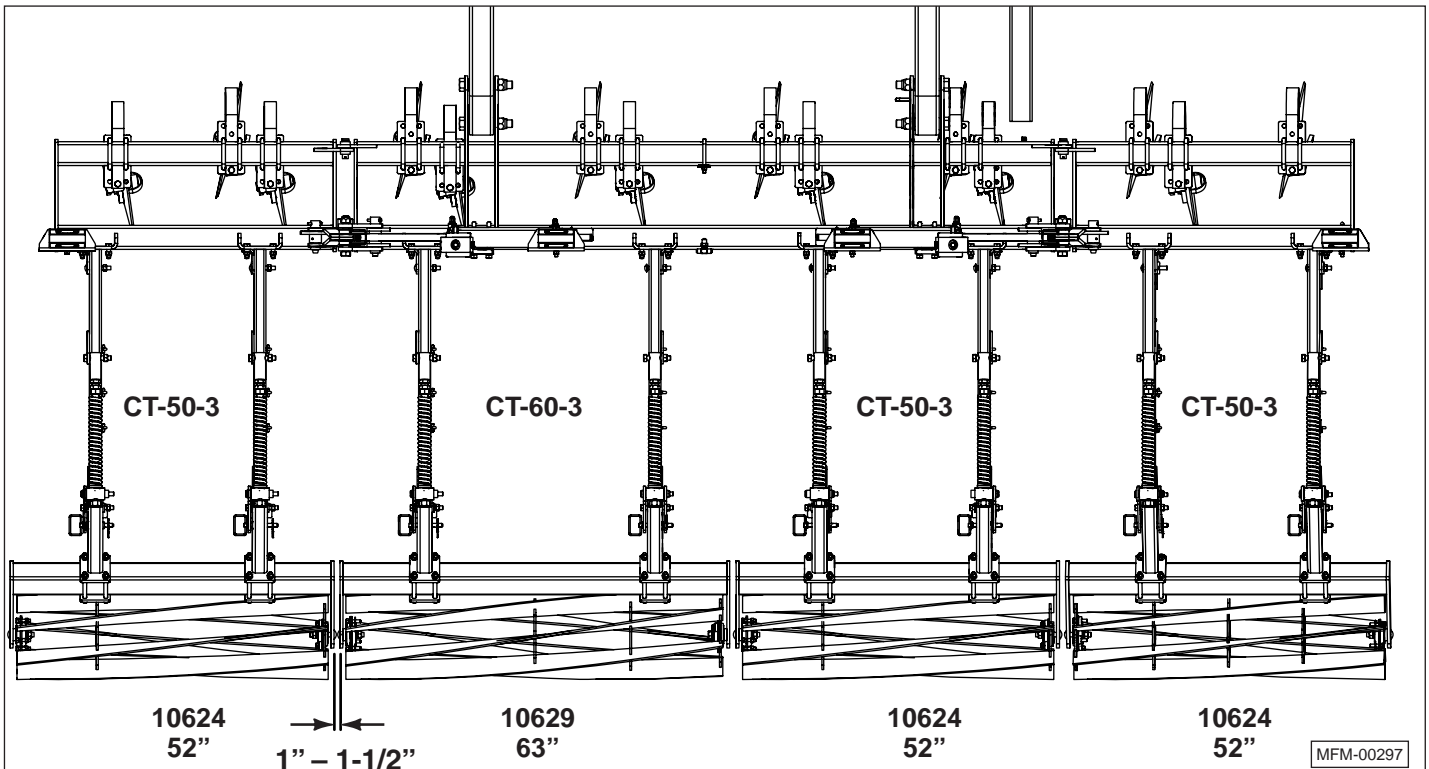

QT-215F - Rolling Basket Layout

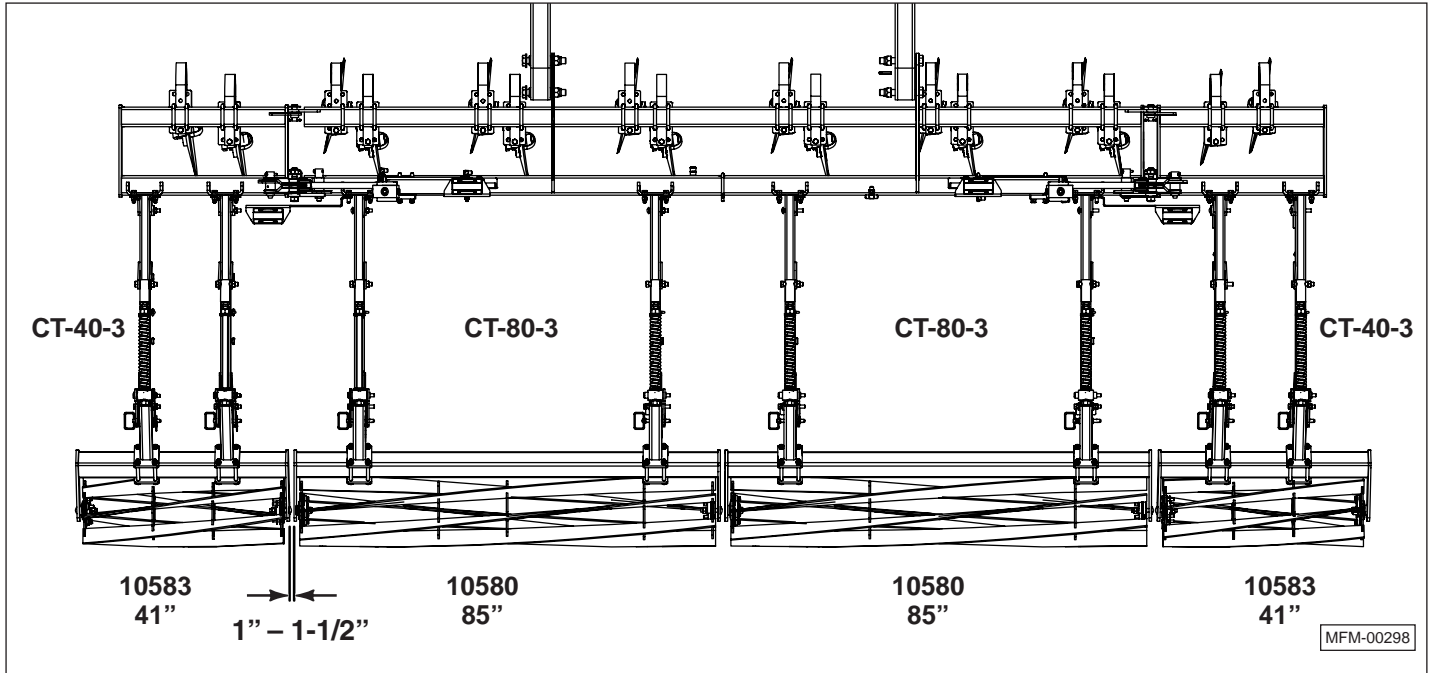

QT-217F - Rolling Basket Layout

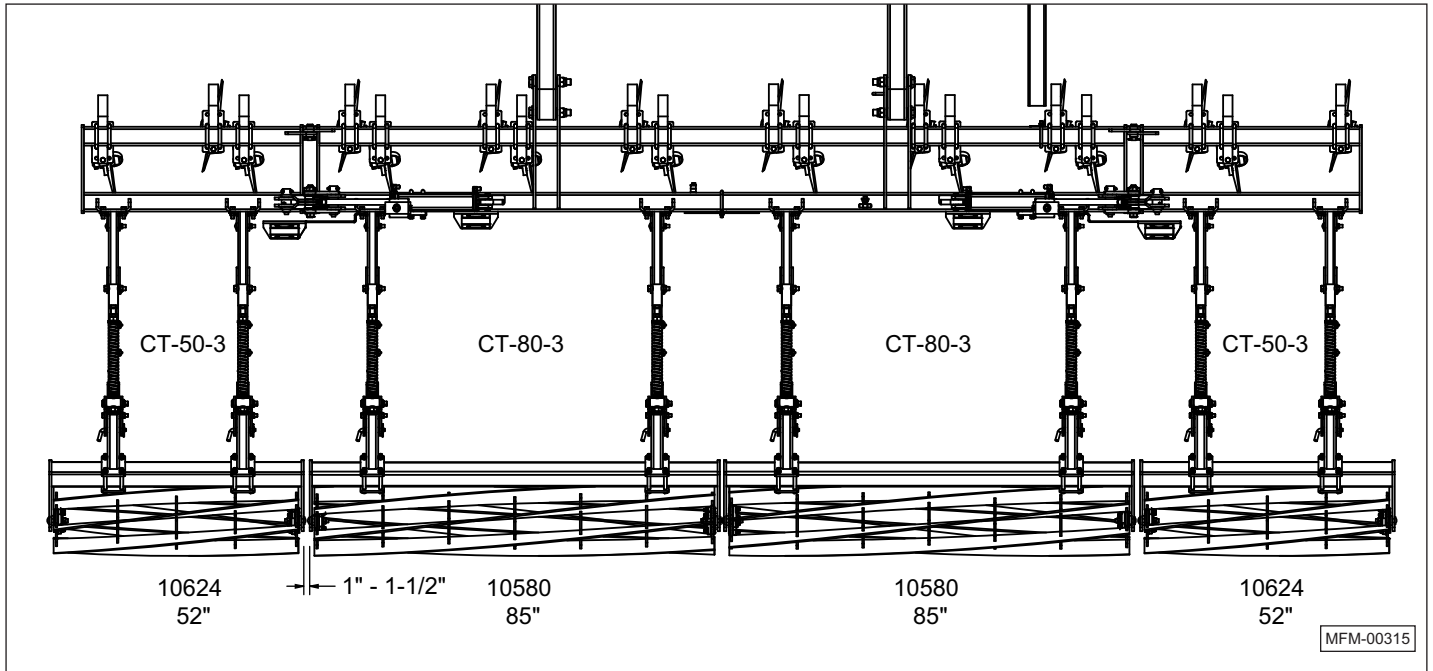

Independent Disk Blade Layout Diagram

QT-209-I Layout

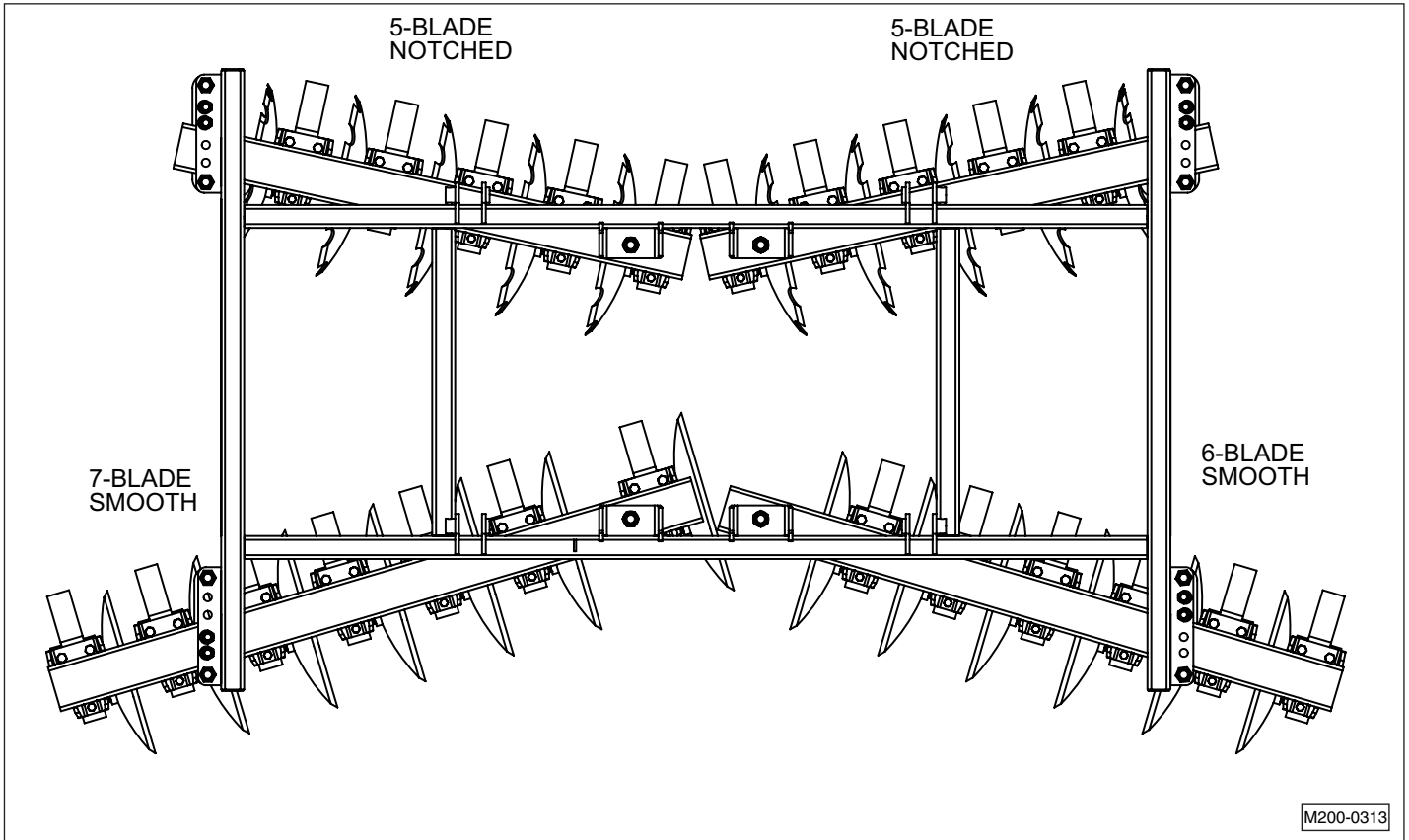

QT-211-I - Layout

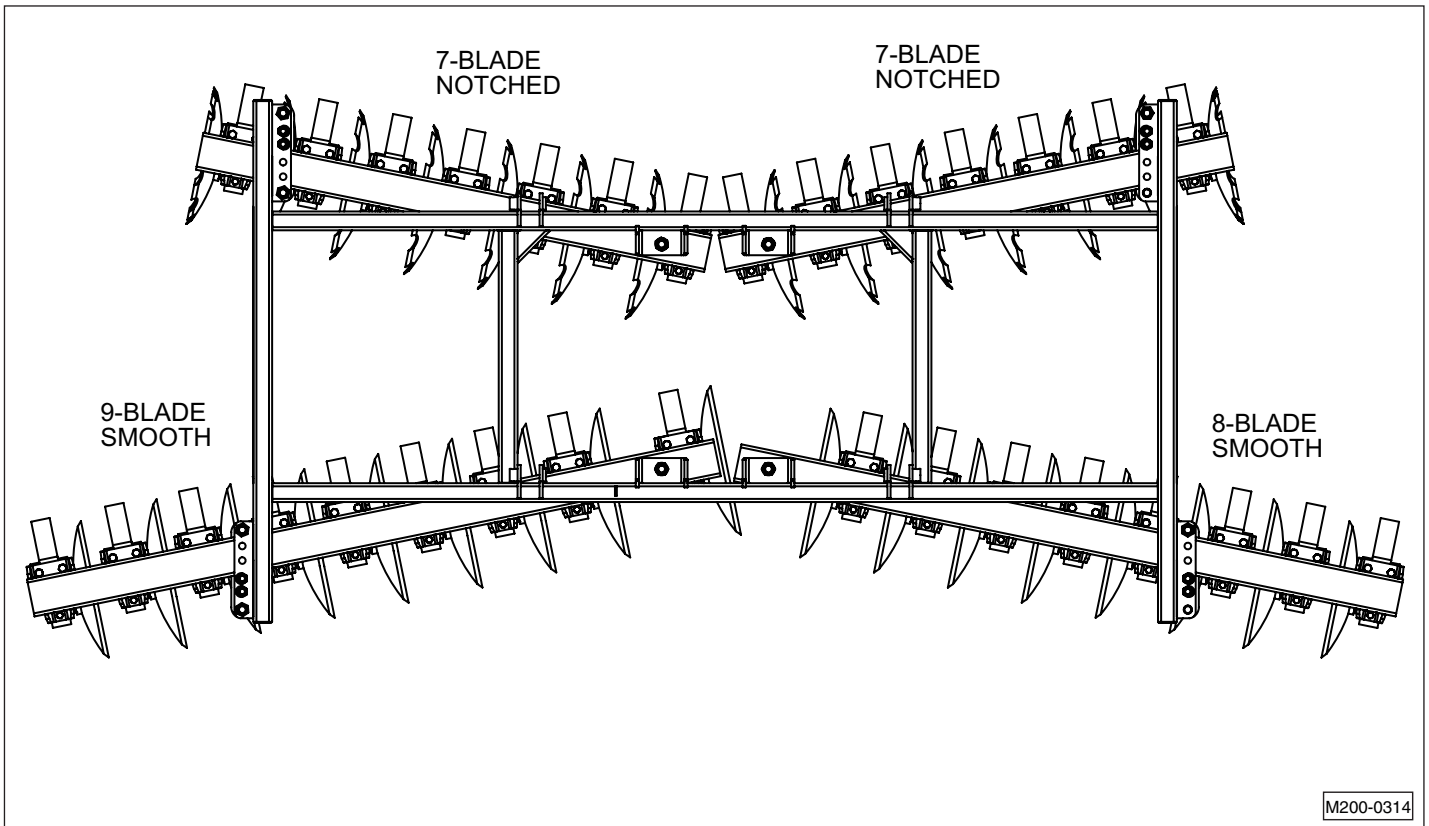

QT-213F-I Layout

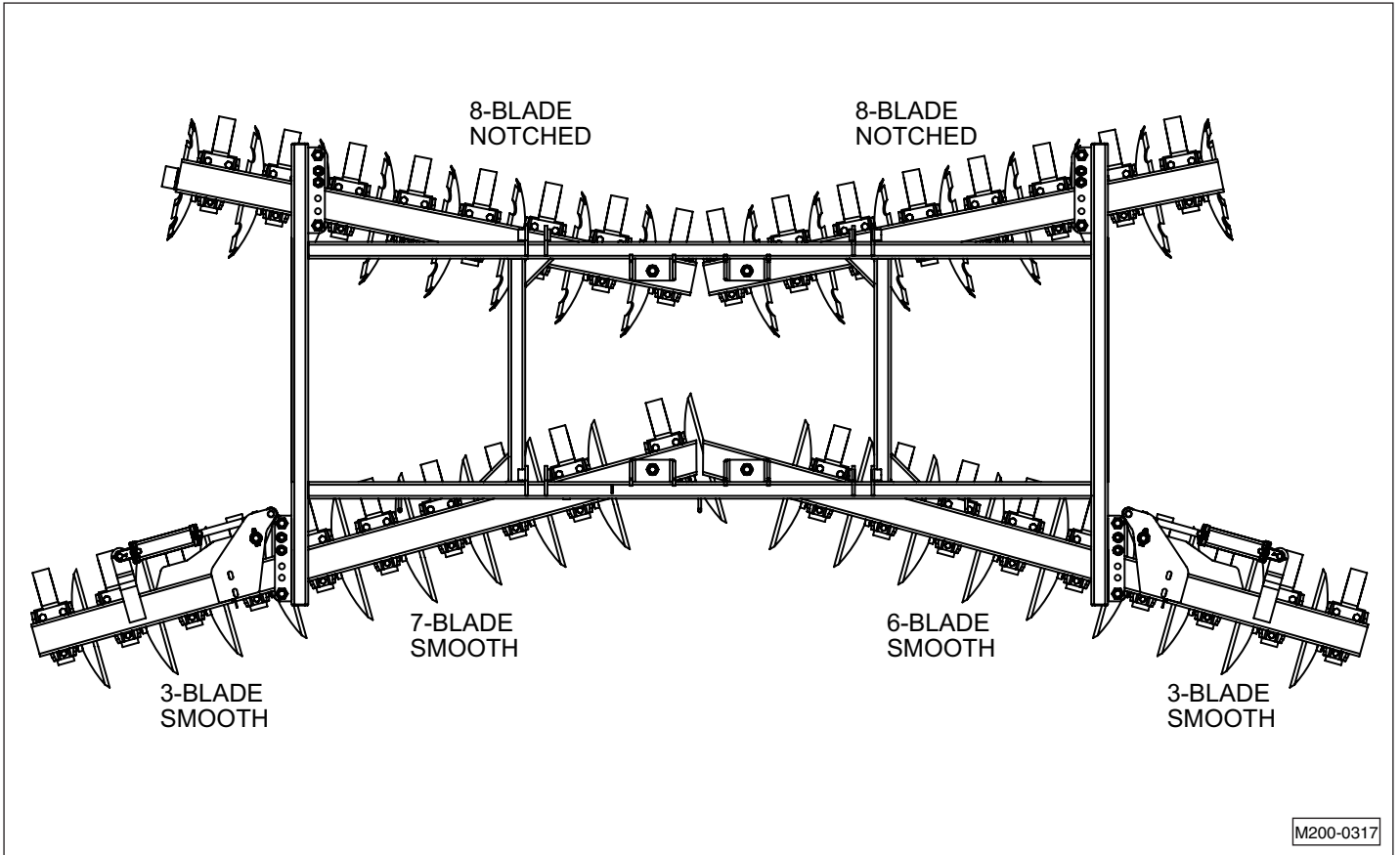

QT-215F-I Layout

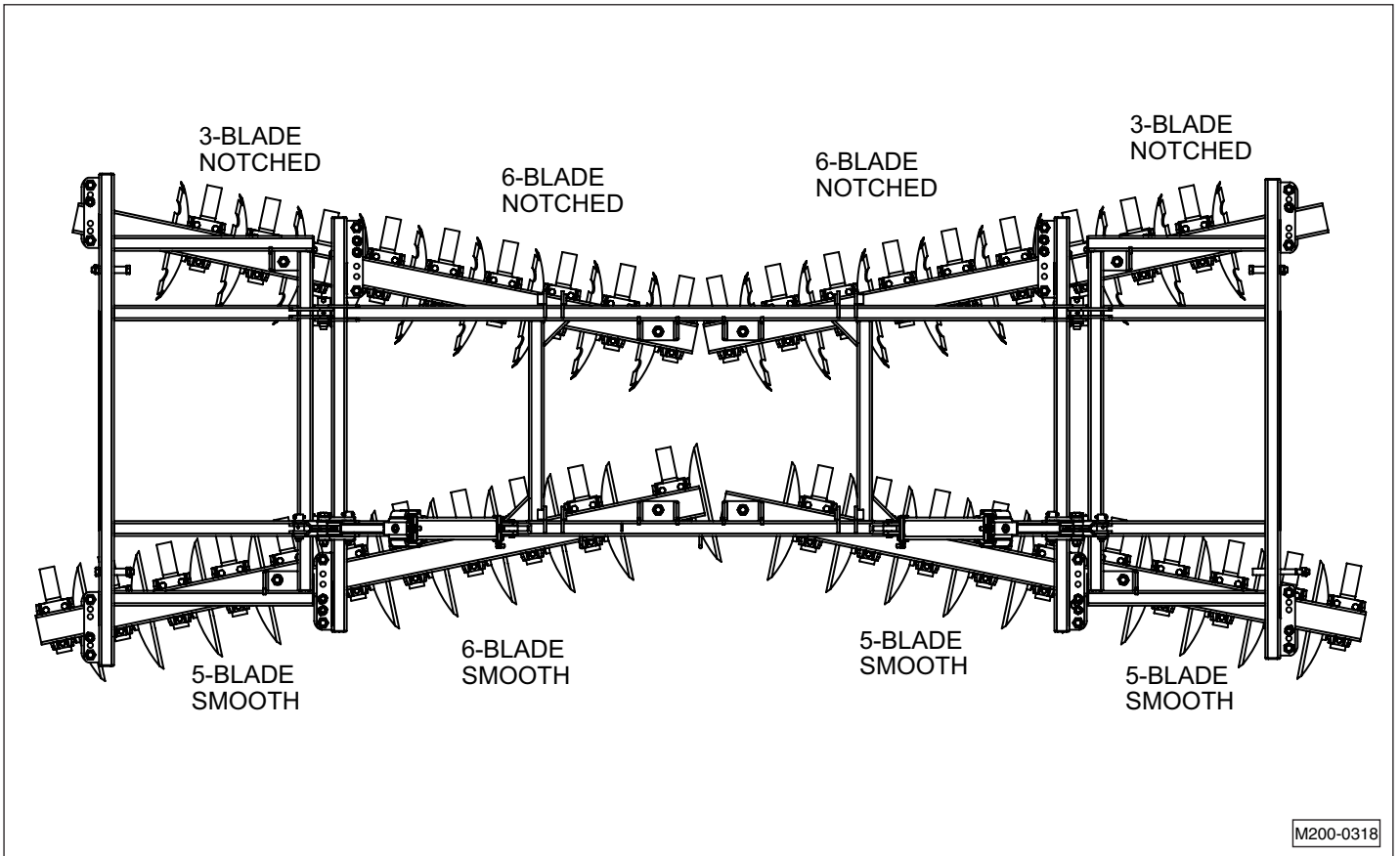

QT-217F-I Layout

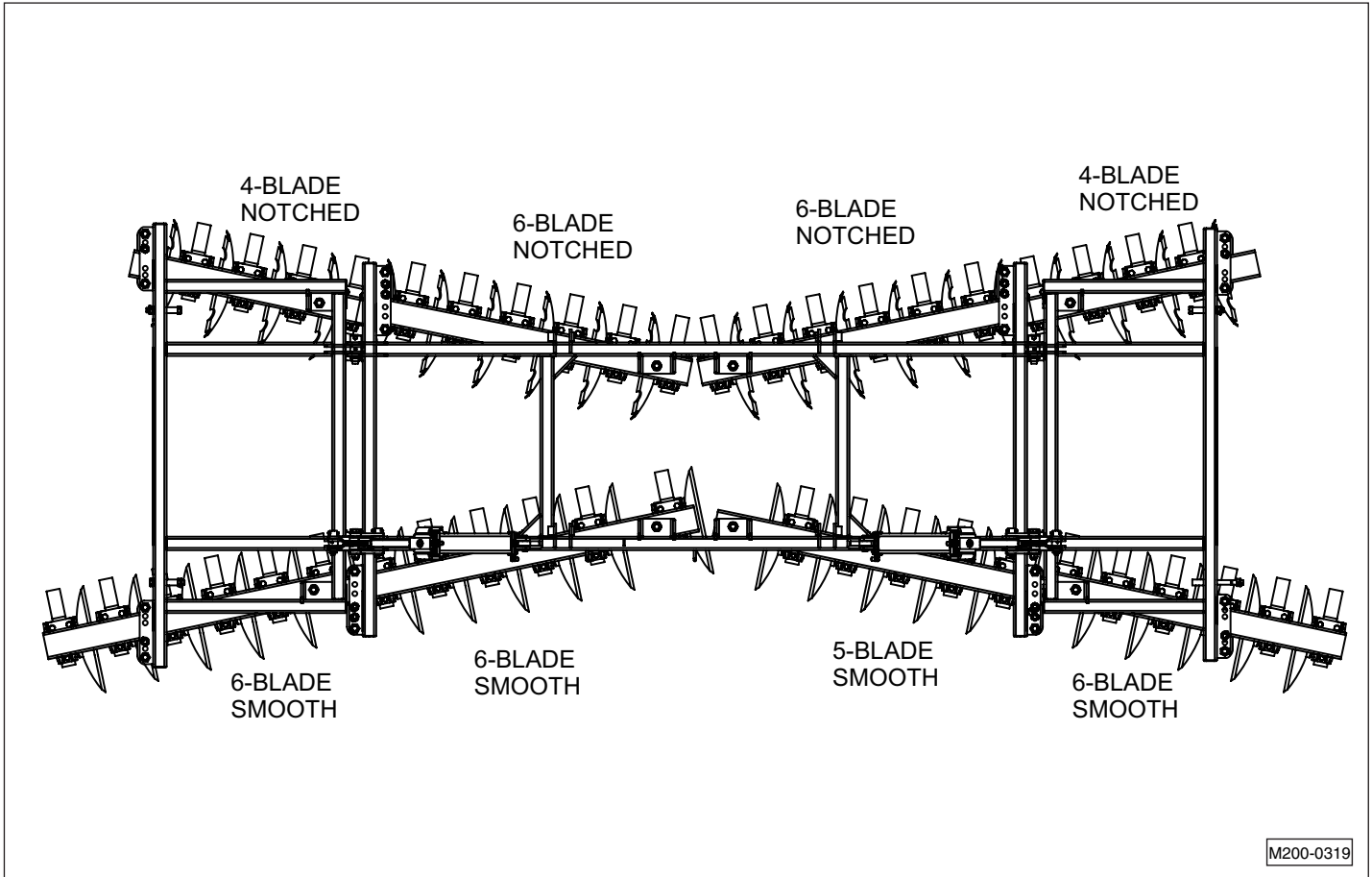

Dealer Contact Information

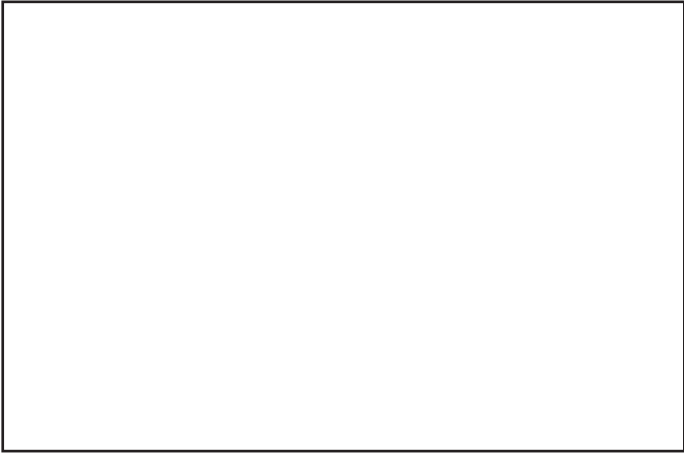

Warranty

Limited Warranty Statement

FULL ONE YEAR WARRANTY

If within one year from the date of purchase, this Quadra-Till fails due to a defect in material or workmanship, McFarlane Mfg. Co., Inc. will repair it, free of charge.

Warranty service is available by simply contacting the nearest McFarlane dealership throughout the United States or Canada.

This warranty applies only while this product is used in the United States or Canada.

This warranty gives you specific legal rights, and you may have other rights which vary from state-to-state.

Serial Number Location

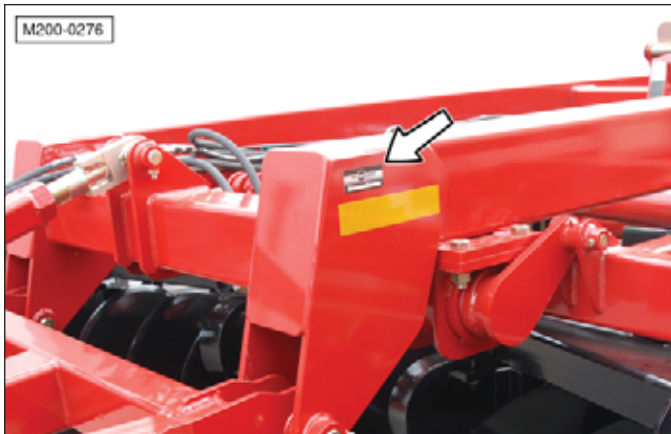

WARRANTY REGISTRATION FORM & INSPECTION REPORT

This form must be filled out by the dealer and buyer and the initialed and signed copy sent to: McFarlane Mfg. Co., Inc., 1259 South Water Street, P.O. Box 100, Sauk City, WI 53583.

WARRANTY REGISTRATION

This form must be filled out by the dealer and signed by both the dealer and customer at the time of delivery.

Customer Name _____ Dealer Name _____

Address _____ Address _____

City, State, Zip Code _____ City, State, Zip Code _____

Phone Number (____) _____

Model _____ Serial Number _____ Delivery Date _____

INSPECTION ITEMS

SAFETY

Buyer's
Initials

Buyer's
Initials

____ Wheel bolts are tightened to the correct torque. Refer to the Tire and Lug Torque Specifications Chart in this manual.

____ All decals are properly installed and readable. Refer to the Hazard and Information Signs section in this manual.

____ Tires are properly inflated. Refer to the Tire and Lug Torque Specifications Chart in this manual.

____ Read and understand all operating and safety instructions in this manual.

____ All fasteners are tightened to the correct torque. Refer to the Bolt Torque Specifications Chart in this manual.

____ All hydraulic hoses move freely without pinching or binding.

____ All hydraulic hoses, cylinders, and/or component fittings are tight with no leakage.

____ All grease fittings have been properly lubricated. Refer to the Lubrication section in this manual.

I have thoroughly instructed the buyer on the above-described equipment; the review included both the Assembly and Operation & Parts manuals, equipment care, adjustments, safe operation, and applicable warranty policy.

Date _____ Dealer's Signature _____

The above equipment and operator's manual have been received by me, and I have been thoroughly instructed as to care, adjustments, safe operation, and applicable warranty policy.

Date _____ Owner's Signature _____

Cut Here to Remove Page

Member of



Dealer Information

**1330 DALLAS STREET, P.O. BOX 100
SAUK CITY, WISCONSIN 53583
PHONE: (608) 643-3322
TOLL FREE: (888) 627-8569
FAX: (608) 643-3976
WEB: www.flexharrow.com**