

# OPERATION AND PARTS MANUAL

## FINALIZER™ 6000 SERIES Secondary Tillage

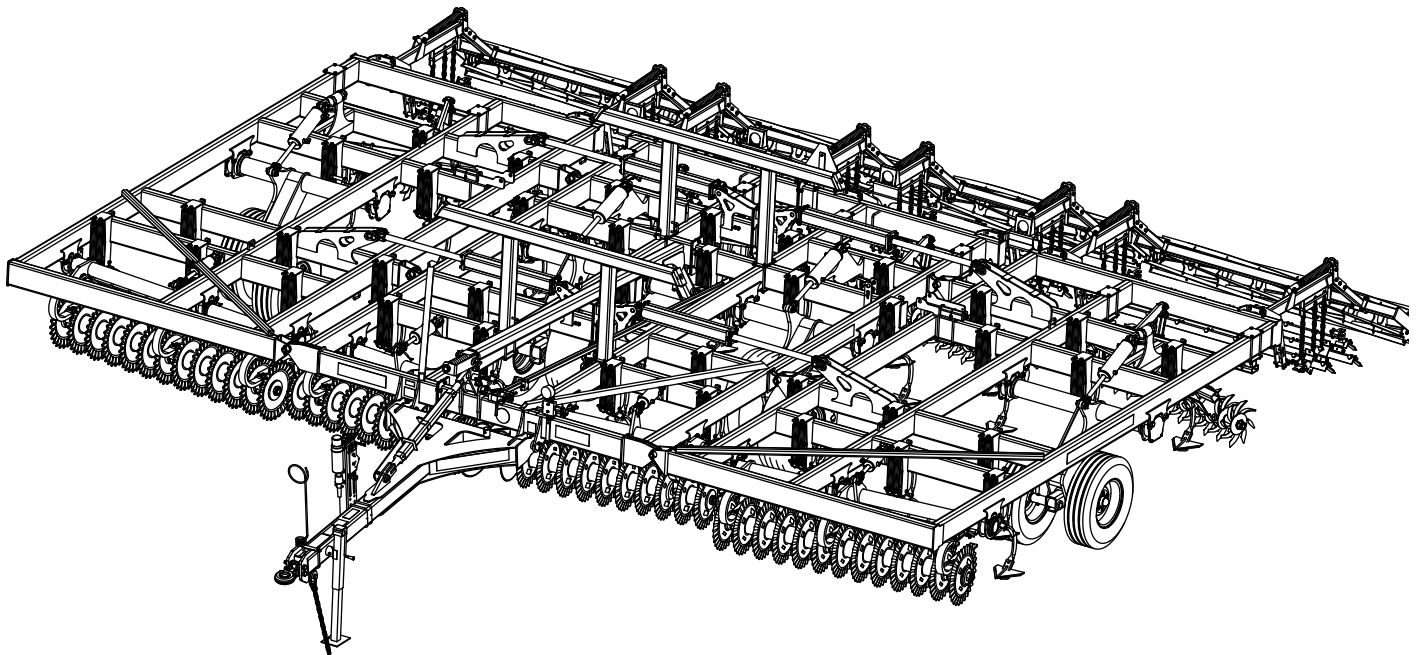

Read and understand the manual. This manual provides information and procedures to safely operate and maintain the Finalizer 6000.



PART NUMBER: 17275 — Serial Number 24702- higher

Learn more at [www.mcfarlaneag.com](http://www.mcfarlaneag.com)

# Table of Contents

Introduction	3	Parts Drawings	36
Product Registration	3	Disk Gang for FN-6000 Series	44
Safety	3	Lift Arm for 3 Bar FA Harrow Sections	45
Safety Alert Symbols	4	3 Bar FA Harrow Section	46
Safety Icons Nomenclature	5	Lift Arm for 5 Bar FA Harrow Section	47
General Operating Safety	6	5 Bar FA Harrow Section	48
Towing Safety	6	Spur-Till Option With Mount for FN-6000	49
Operation Safety	6	Spur-Till Gang for FN-6000 Series	50
Assembly Safety	6	Rolling Basket for FN-6000 Series	51
Maintenance Safety	6	Lighting Diagram for FN-6000 Series	54
Component Nomenclature	7	Hub Components for HD-1371	55
Component Locations	7	Hub Components for RT-3181	56
Hydraulic Requirements	8	Wheel Lift Hydraulic Layout for FN-6000	57
Horsepower Range	8	Wing Fold Hydraulic Layout for FN-6000	58
Display of Hazard and Informational Signs	9	Disk Gang Hydraulic Layout for FN-6000	59
Towing	11	Spur-Till Hydraulic Layout for FN-6000 Series	60
General Safety	11	Shank Layout Diagram for FN-6024	61
Safety	14	Spur-Till Layout Diagram for FN-6024	62
Operation	18	3 Bar w/ Rolling Basket Diagram for FN-6024	63
Safety	18	Shank Layout Diagram for FN-6029	64
Initial Setup	18	Spur-Till Layout Diagram for FN-6029	65
Adjustment	21	3 Bar w/ Rolling Basket Diagram for FN-6029	66
Preparing for Transport	24	Shank Layout Diagram for FN-6032	67
Maintenance	25	Spur-Till Layout Diagram for FN-6032	68
Safety	25	3 Bar w/ Rolling Basket Diagram for FN-6032	69
Tire and Lug Torque Specifications	26		
Bolt Torque Chart	26		
Maintenance Procedures	29		
Lubrication Locations Drawing	31		
Hydraulic Component Safety	32		
Storage	33		
Warranty	33		
Troubleshooting	34		
Parts Section	35		

## Introduction

The 6000 Series Finalizer from McFarlane Mfg. features wavy, serrated Cobra disk blades, loosens the top one to five inches of the soil yet leaves the seedbed firm. This ensures accurate seed depth at planting, resulting in even emergence and better yields. Smoothing uneven ground and removing small weeds are done quickly at the 6-8mph operating speeds.

The Finalizer is available in a 24', 29' and 32' folding frames. The horsepower required to pull the Finalizer is approximately 8-9 hp per foot of width.

## Contact Information

If you have questions not answered in this manual, require additional copies, or the manual is damaged, please contact your local dealer or:

McFarlane Mfg. Co., Inc.  
1330 Dallas Street  
P.O. Box 100  
Sauk City, WI 53583

Phone: (608) 643-3322

Toll Free: (888) 627-8569

Fax: (608) 643-3976

E-mail: [info@mcfarlanemfg.com](mailto:info@mcfarlanemfg.com)

Web: [www.mcfarlaneag.com](http://www.mcfarlaneag.com)

## Product Registration:

All McFarlane Ag products need to be registered to the owner prior to use.

The dealer is required to submit the product registration through the McFarlane dealer portal.

Failure to register the product may result in future warranty claims being rejected.

### Register at:

[mcfarlaneag.com/product-registration](http://mcfarlaneag.com/product-registration)

### Scan to Register:



## Safety

### General

Safety of the operator and bystanders is one of the main concerns in designing and developing a new piece of equipment. Designers and manufacturers build in as many safety features as possible. However, every year many accidents occur which could have been avoided by a few seconds of thought and a more careful approach to handling the equipment.

Most work related accidents are caused by failure to observe basic safety rules or precautions. An accident can often be avoided by recognizing potentially hazardous situations before an accident occurs. As you assemble, operate, tow, or maintain the Finalizer (unit), you must be alert to potential hazards. You should also have the necessary training, skills, and tools to perform any assembly or maintenance procedures.

Improper operation and maintenance of this unit could result in a dangerous situation that could cause injury or death.

## WARNING



**Do not use or tow the unit until you read and understand the information contained in this manual.**



**Safety precautions and warnings are provided in this manual and on the unit. If these hazard warnings are not heeded, bodily injury or death could occur to you or to other persons.**

McFarlane cannot anticipate every possible circumstance that might involve a potential hazard. The warnings in this manual and on the product are, therefore, not all-inclusive. If a method of operation not specifically recommended by us is used, you must satisfy yourself that it is safe for you and for others. You should also ensure that the unit will not be damaged or be made unsafe by the methods that you choose.

The information, specifications, and illustrations in this manual are based on the information that was available at the time this material was written and can change at any time.

## Safety Alert Symbols



This is the safety alert symbol. It is used to alert you to potential personal injury hazards. Obey all safety messages that follow this symbol to avoid possible injury or death.

This manual contains DANGERS, SAFETY INSTRUCTIONS, CAUTIONS, IMPORTANT NOTICES, and NOTES which must be followed to prevent the possibility of improper service, damage to the equipment, personal injury, or death. The following key words call the readers attention to potential hazards.

Hazards are identified by the "Safety Alert Symbol" and followed by a signal word such as "DANGER", "WARNING", or "CAUTION".

### **DANGER**

**Indicates an imminently hazardous situation which, if not avoided, will result in death or serious injury. This signal word is limited to the most extreme situations.**

---

### **WARNING**

**Indicates a potentially hazardous situation which, if not avoided, could result in death or serious injury.**

---

### **CAUTION**

**Indicates a potentially hazardous situation which, if not avoided, may result in minor or moderate injury.**

---

### **NOTICE**

*Indicates that equipment or property damage can result if instructions are not followed.*

---

### **SAFETY INSTRUCTIONS**

**Safety instructions (or equivalent) signs indicate specific safety-related instructions or procedures.**

---

**NOTE:** Contains additional information important to a procedure.

## Safety Icons Nomenclature

This manual and the equipment has numerous safety icons. These safety icons provide important operating instructions which alert you to potential personal injury hazards.



## Personal Protection/Important Information

-  Read the manual
-  Maintenance procedure
-  Crush hazard
-  Eye protection
-  Hand protection
-  Head protection
-  Hearing protection
-  Inspect equipment
-  OEM parts only
-  Place in neutral
-  Protective shoes
-  Remove key
-  Damaged hazard label
-  Set parking brake
-  Slow vehicle placard
-  Stop engine
-  Support stand usage
-  Use proper tools
-  Visually inspect

## Prohibited Actions

-  Do not alter or modify
-  Do not leave out tools
-  Do not weld
-  No alcohol
-  No children
-  No drugs
-  No open flame
-  No passengers
-  No riders
-  No smoking

## Hazard Avoidance

-  Block wheels
-  Crushing hazard (body)
-  Crush hazard (foot)
-  Crush hazard (rolling over)
-  Defective or broken part
-  Entanglement hazard
-  Explosive separation hazard
-  Falling hazard
-  Fire hazard
-  High-pressure fluid hazard
-  Hose damage
-  Hot surface

-  Maintain safe distance
-  Overturn hazard
-  Pinch point hazard
-  Pressure alert / check pressure
-  Projectile hazard
-  Safety alert symbol
-  Sharp object hazard
-  Slipping injury
-  Tripping injury
-  Zero pressure

## General Operating Safety

### **WARNING**



**Read And Understand Manual**  
To prevent personal injury or even death, be sure you read and understand all of the instructions in this manual and other related OEM equipment manuals! This equipment is dangerous to children and persons unfamiliar with its operation. The operator should be a responsible adult familiar with farm machinery and trained in this equipment's operations. Do not allow persons to operate or assemble this unit until they have read this manual and have developed a thorough understanding of the safety precautions and how it works.

This unit was designed for a specific application; DO NOT modify or use this unit for any application other than which it was designed.

Units operated improperly or by untrained personnel can be dangerous!



**Hazard And Information Signs**  
Replace any missing or hard-to-read decals. Decal placement and part numbers can be found in the Nomenclature section of this manual.



**Damaged Parts Hazard**  
Do not use this unit if it is in need of repair. If you believe the unit has a defect which could cause damage, injury, or death, you should immediately stop using the unit.



**Fall Hazard**  
Do not use the unit as a work platform. Do not stand on top of the unit at any time. Do not ride on the unit or allow others to ride on it.



**Entanglement Hazard**  
Do not wear loose fitting clothing which may become entangled in moving parts.



**Crush Hazard (Rolling Over)**  
When disconnecting the unit or leaving the operator's seat:

1. Stop the tractor or towing vehicle.
2. Shut off the engine and remove the ignition key.
3. Set the brakes.
4. Make sure wheel cylinder transport locks are attached.
5. Relieve hydraulic fluid pressure.
6. If parking the unit, make sure jack stand is lowered and retaining pin is installed.



**Injury Hazard**  
Do not permit children to play on or around the stored unit.

### **WARNING**



**Impaired Operator Hazard**  
Do not attempt to operate this unit under the influence of drugs or alcohol. Review the safety instructions with all users annually.

**Personal Protection Equipment**  
When working around or operating this unit, wear appropriate personal protective equipment. This list includes but is not limited to:



- A hard hat
- Protective shoes with slip resistant soles
- Protective goggles, glasses, or face shield
- Heavy gloves and protective clothing



**Safe Distance**  
Keep all bystanders, especially children, away from the unit while in operation.

### **SAFETY INSTRUCTIONS**



To prevent injury, use a tractor equipped with a Roll Over Protective System (ROPS).



**Visually Inspect**  
Visually inspect the unit for any loose bolts, worn parts, or cracked welds, and make necessary repairs before using the unit.

## Towing Safety

For towing safety information, refer to the Towing section.

## Operation Safety

For operating safety information, refer to the Operation section.

## Assembly Safety

For assembly safety information, refer to the separate Assembly manual.

## Maintenance Safety

For maintenance safety information, refer to the Maintenance section.

# Component Nomenclature

## Component Locations

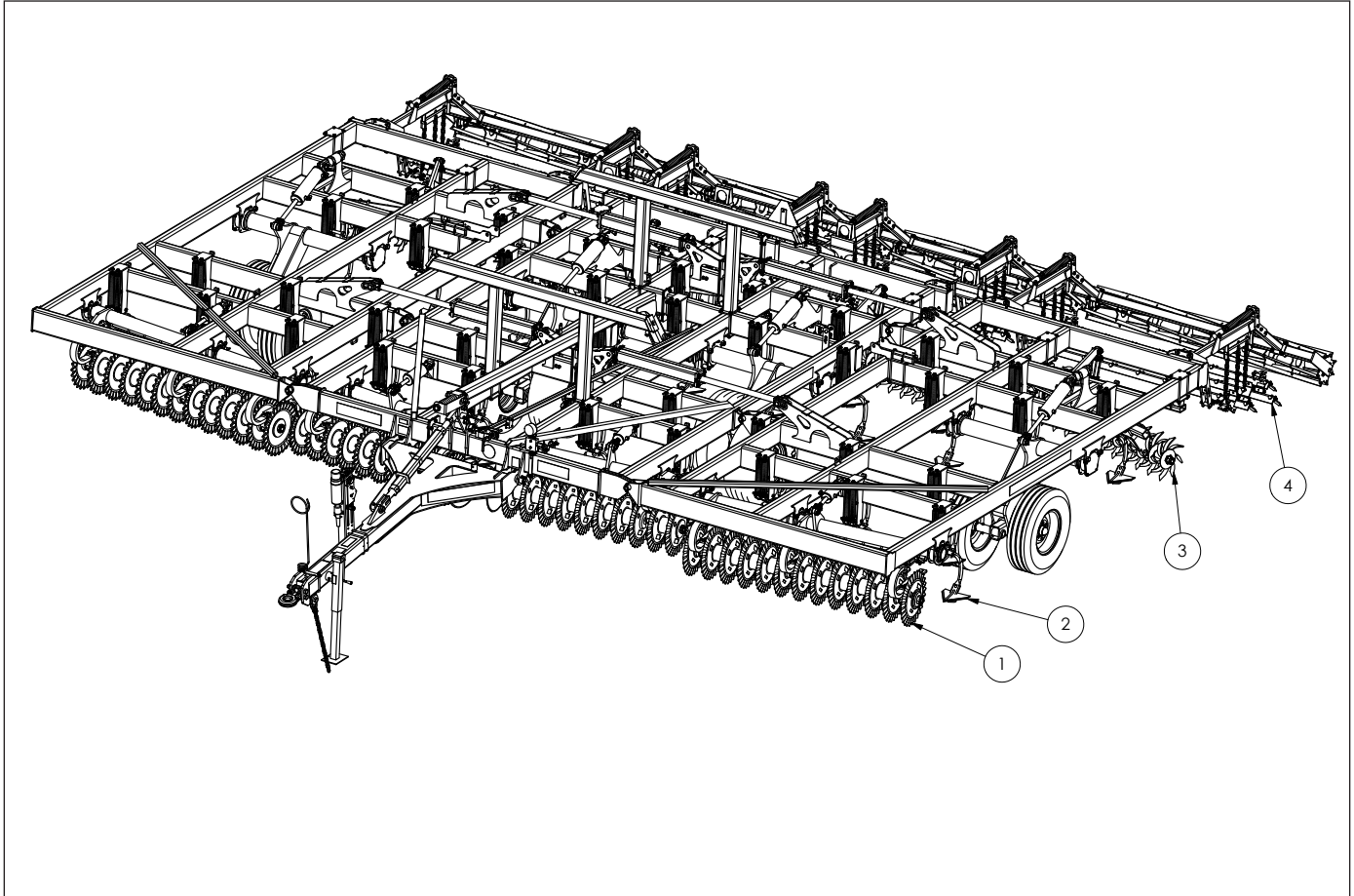

The Finalizer is comprised of four components: (1) Cobra disk gangs, (2) shanks with Talon™ sweep, (3) Spur-Till treaders, and (4) Finishing configuration (3-bar harrow with single rolling basket or 5-bar harrow).

## **Specifications (same for all finishing configurations)**

### **Hydraulic Requirements**

This unit operates with hydraulic pressures of 2500 to 3000 psi (170 to 205 bars).

### **Horsepower Range**

FN-6024-ST3RB — 240 to 330

FN-6029-ST3RB — 280 to 400

FN-6032-ST3RB — 320 to 445

### **Tillage Depths**

Sweep depth up to 5" (12.7 cm)

### **Tongue Weight**

Tongue weight of the unit is approximately 700 lbs. (318 kgs)

### **Overall Weight (GVWR)**

FN-6024-ST3RB — 17,140

FN-6029-ST3RB — 19,757

FN-6032-ST3RB — 20,864

### **Transport Width**

FN-6024-ST3RB — 15'4"

FN-6029-ST3RB — 15'4"

FN-6032-ST3RB — 15'4"

### **Transport Height**

FN-6024-ST3RB — 9'11"

FN-6029-ST3RB — 12'3"

FN-6032-ST3RB — 13'6"

### **Working Tillage Width (Cut Width)**

FN-6024-ST3RB — 24'3"

FN-6029-ST3RB — 28'9"

FN-6032-ST3RB — 31'9"

### **Field Capacity (acre/hr @ 6-8 mph)**

FN-6024-ST3RB — 15-20

FN-6029-ST3RB — 18-24

FN-6032-ST3RB — 20-26

### **Towing Speed**







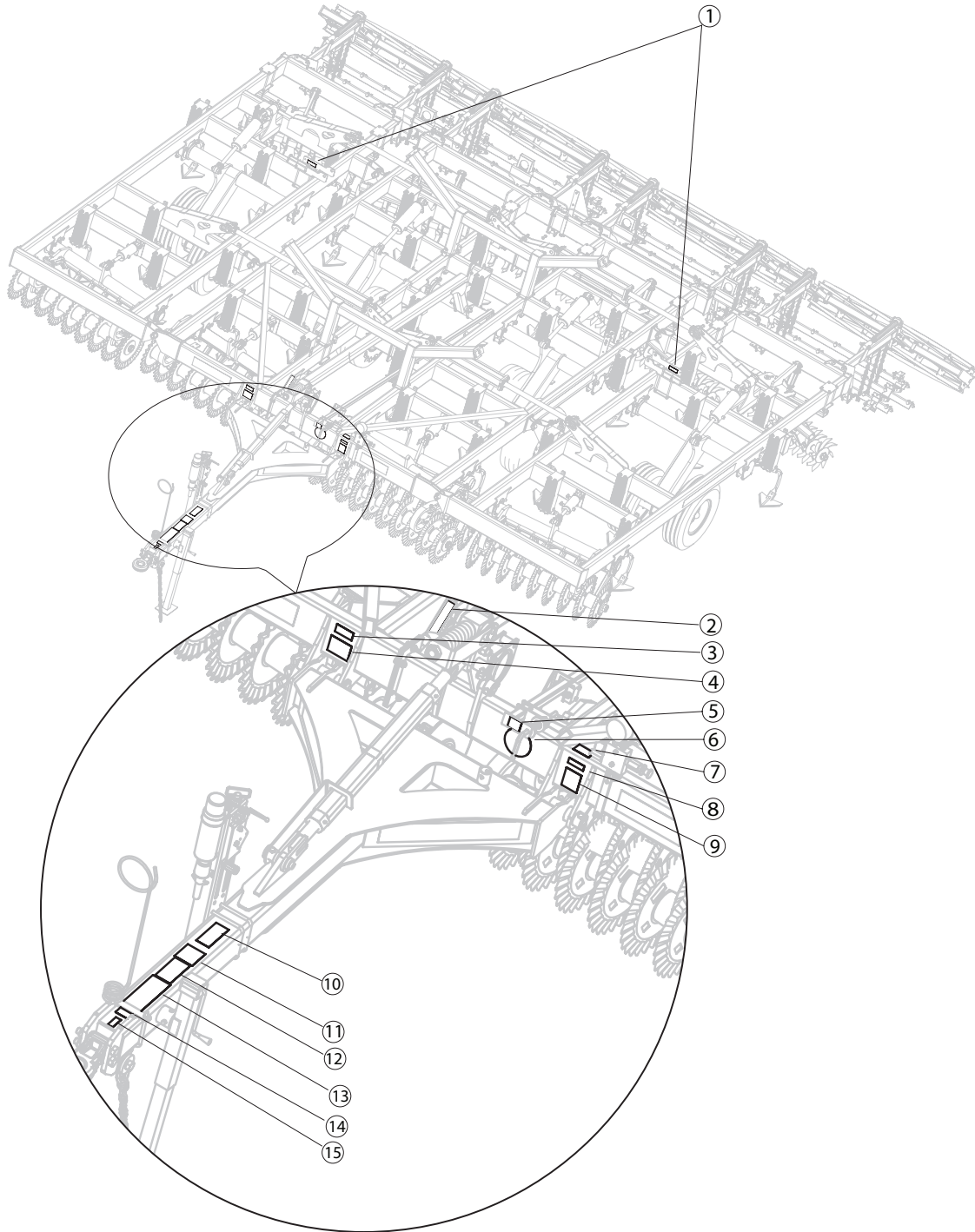

Towing speeds should not exceed 20 mph (32 kph)  
Field operating speeds should be 6-8 mph (9-13 kph).





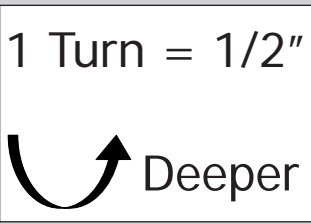

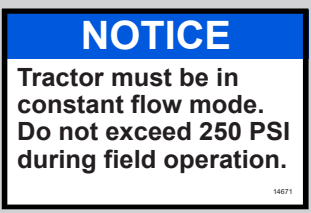
## Instructions for Display of Hazard and Informational Signs

- It is the responsibility of the customer to know the lighting and marking requirements of the local highway authorities and to install and maintain the equipment to provide compliance with the regulations. Add extra lights when transporting at night or during periods of limited visibility.
- Keep safety signs clean and legible at all times. Replace safety signs that are missing or have become illegible.

- Do not paint over, remove, or deface any safety signs or warning decals on your equipment. Observe all safety signs and practice the instructions on them.
- Replacement parts that display a safety sign should display the same sign.
- Make sure the hazard warning labels or other information decals are legible and attached to the unit before use.
- Safety signs are available from your Distributor, Dealer Parts Department, or the factory

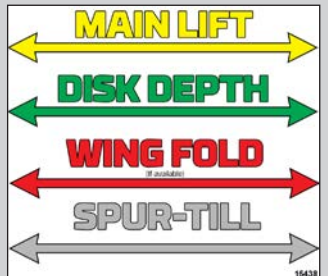

Item	Part Number	Description
1	14050	
2	15461	
3	DC-106	
4	16293	
5	DC-225	
6	14039	
7	14671	
8	11172	

Item	Part Number	Description
9	16400	
10	DC-271	
11	15438	
12	15439	
13	DC-230	
14	11170	
15	14051	

# Assembly

Refer to the separate Finalizer Assembly manual for complete assembly instructions.

## Towing

### General Safety

#### **SAFETY INSTRUCTIONS**



Towing the Finalizer requires care! Both the unit and tow vehicle must be in good working condition. Securely attach to towing unit. Use a high strength, appropriately sized hitch pin with a mechanical retainer and attach safety chain.



Make sure the hitch and coupling on the towing vehicle are rated equal to, or greater than, the unit's "gross vehicle weight rating" (GVWR). Refer to the specification section.



Make sure the safety chain is securely fastened to the tow vehicle.



Check the tires for tread wear, inflation pressure, and overall condition.



Inspect the hitch and coupling for wear or damage. DO NOT tow the unit using a defective hitch or coupling!



Make sure directional, brake, and running lights are connected and working properly.



Make sure the lug nuts holding the wheels are tight (torque to specifications) and that none are missing.



When towing the unit on the highway, make sure the "Slow Moving Vehicle" placard is clearly visible.





Do not allow anyone to stand between the tongue or hitch and the towing vehicle when backing up to the equipment.



Make sure that the area is clear of children, animals, and other obstacles before using.





## Safety Chain

### SAFETY INSTRUCTIONS

- If the unit will be transported on a public highway, the safety chain must be attached to the tow vehicle.
-  Always follow state and local regulations regarding a safety chain when towing farm equipment on a public highway.
-  Be sure to check with local law enforcement agencies for any local regulations or restrictions.
- Do not use any device other than the safety chain that was supplied with the unit. Only a safety chain (not an elastic or nylon/plastic tow strap) should be used to retain the connection between the tow vehicle and the unit in the event of separation of the primary attaching system.

## Bystanders

### SAFETY INSTRUCTIONS

-  Beware of physical surroundings and especially bystanders, particularly children, before moving the unit! This is particularly important with higher noise levels and quiet cabs, as you may not hear people shouting.
-   **NO PASSENGERS ALLOWED** - Do not carry passengers anywhere on or in the tractor, except as required for operation.
-  Do not allow anyone to ride on the unit while it is moving.

## Towing and Maximum Towing Speed

### SAFETY INSTRUCTIONS

- Operate the towing vehicle from the operator's seat only.
- Do not exceed a towing speed of more than 20 mph (32KPH) on a public roadway.
-  Remember, tires supplied by the manufacturer are designed to operate **LESS THAN 20 mph**. Do not exceed or tire failure may occur.

## Highway and Transport Operations

### SAFETY INSTRUCTIONS

- Make sure the wheel cylinder transport locks are installed, the wing lock pins are in place, and the jack stand is in its storage position before transporting the unit.

### SAFETY INSTRUCTIONS

- Never use independent braking with unit in tow as loss of control and/or upset of unit may result.
- Always drive at a safe speed relative to local conditions and ensure that your speed is low enough for an emergency stop to be safe and secure. Keep speed to a minimum.
- Reduce speed prior to turns to avoid the risk of overturning.
- Avoid sudden uphill turns on steep slopes.
- Always keep the tractor or towing vehicle in gear to provide engine braking when going downhill. Do not coast.
- Use approved accessory lighting or flags and necessary warning devices to protect operators of other vehicles on the highway during daylight and nighttime transport. Various safety lights and devices are available from your dealer.
- The use of flashing amber lights is acceptable in most localities. However, some localities prohibit their use. Local laws should be checked for all highway lighting and marking requirements.
- When driving the tractor and equipment on the road or highway, use flashing amber warning lights and a slow moving vehicle (SMV) identification emblem.
- Be a safe and courteous driver. Always yield to oncoming traffic in all situations, including narrow bridges, intersections, etc. Plan your route to avoid heavy traffic.
- Be observant of bridge loading ratings. Do not cross bridges rated lower than the gross weight at which you are operating.
- Watch for obstructions overhead and to the side while transporting.
- Always operate equipment in a position to provide maximum visibility at all times. Make allowances for increased length and weight of the equipment when making turns, stopping, etc.

## Pre-towing Checklist

1. Before towing, make sure the maintenance on the tractor and the unit are current. This is very important because towing puts additional stress on the tow vehicle.
2. Check and correct the tire pressures on the tow vehicle and the unit. Refer to the Tire and Lug Torque specification chart in the manual.
3. Make sure the hitch, coupler, and any other equipment that connects the unit and the tow vehicle are properly secured and adjusted. Always inspect the hitch and tongue for cracks when hooking up.

### **! WARNING**

**! Substandard Parts Hazard**  
**If towing the unit with a draw bar, use only an OEM certified, hardened drawbar pin with a retainer clip. Do not use homemade pins, bolts, or any other type of retaining device. Always install the retainer clip, making sure the hitch and unit are securely fastened to the tow vehicle.**

**Using a pin not intended for this type of towing, can result in unexpected separation of the unit from the tow vehicle resulting in equipment damage and personal injury.**

4. Verify the appropriate Category 3 or Category 4 hitch is securely installed.

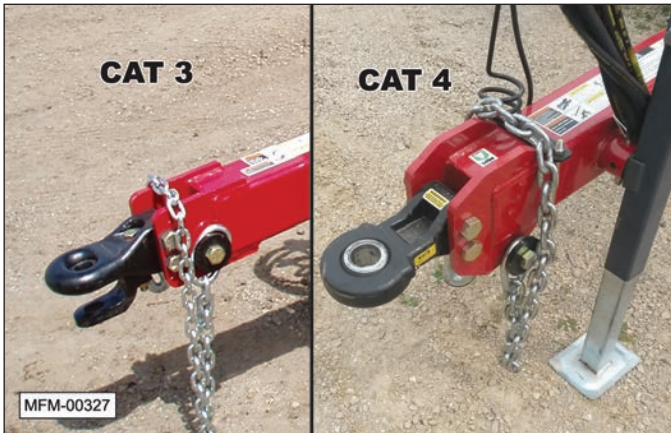

**! Unexpected Separation Hazard**  
**If the safety chains do not have a current certification tag, do not use the unit until properly certified chains are installed. Substandard safety chains could allow the unit to separate from the tow vehicle resulting in equipment damage and personal injury.**

5. Attach the safety chain from the unit to the tow vehicle. The safety chain should be long enough for tight turns. Don't allow the chain to drag on the pavement because it will wear the chain links causing an unsafe condition.
6. Make sure the electrical wiring harness for the running lights and taillights is properly connected and not touching the road, but loose enough to make turns without disconnecting or damaging the wires.
7. Have an observer confirm all running lights, brake lights, turn signals, and hazard lights are working on both the tow vehicle and the unit.
8. Verify the brakes on the tow vehicle are operating correctly.
9. Make sure transport locks are securely in place around the cylinder rods.
10. Make sure the jack stand is raised and locked in the storage position.
11. Make sure the wing lock pins are in place.
12. Check mirrors of the tow vehicle to make sure you have good visibility.
13. Check routes and restrictions on bridges and tunnels.

### **! WARNING**

## Safety

### SAFETY INSTRUCTIONS

Make sure that anyone who will be operating the unit or working on or around the unit reads and understands all the operating, maintenance, and safety information in the operator's manual and other related OEM equipment manuals before using or towing the unit.



### Prior to Connecting Unit

Make sure the unit is resting on the ground or the transport locks are securely installed over the wheel cylinder rods before attaching the unit to the tractor.



### SAFETY INSTRUCTIONS



If the unit is not resting on the ground, make sure wheel chocks are securely fitted on both sides of each wheel.

## ⚠️ WARNING



### Crush Hazard

The tongue weight of the unit is approximately 700 lbs. (318 kgs.). Use care when lifting or attaching the unit to the tractor. Never place any part of your body under the tongue or hitch assembly.

### Hydraulic Pressure



This unit operates with hydraulic pressures of 2500 to 3000 psi (170 to 205 bars).



### High-Pressure Fluids

1. Check or tighten all connections BEFORE pressurizing system.
2. Release all pressure before removing hoses and/or valves by:
  - a. Stopping engine.
  - b. Holding hydraulic control levers in float or neutral position.



3. DO NOT use your bare hand to check for potential leaks. Always use a board or cardboard when checking for a leak.

Escaping hydraulic fluid under pressure, even a pinhole size leak, can penetrate body tissue, causing serious injury and possible death. If fluid is injected into your skin, it must be treated immediately by a doctor familiar with this type of injury.

## Tow Chain



A certified tow chain is supplied with each unit. This chain must be attached to the tractor during towing or operation of the unit.

### SAFETY INSTRUCTIONS



- Inspect the chain annually for wear or damage.



- Do not replace the chain with anything other than an OEM certified replacement.

## Connecting to the Tractor

1. Raise the jack stand and connect the tongue to the tractor. The tongue weight of the unit is approximately 700 lbs. (318 kgs).



**Note:** If a drawbar pin is used, it should be an OEM certified pin and retainer clip. On category 3 pintle hitches use a 1-1/2" (38 mm) pin. On category 3 clevis hitch use a 1-1/4" (32 mm) pin. On category 4 articulating ball pintle hitch use a 2" (51 mm) pin.

### **WARNING**

**!** Unexpected Separation Hazard  
**If towing the unit with a drawbar, use only a certified, hardened drawbar pin with a retainer clip. Do not use homemade pins, bolts, or any other type of retaining device. Always install the retainer clip, making sure the hitch and unit are securely fastened to the tow vehicle.**

Using a pin not intended for this type of towing can result in unexpected separation of the unit from the tow vehicle, resulting in equipment damage and personal injury.

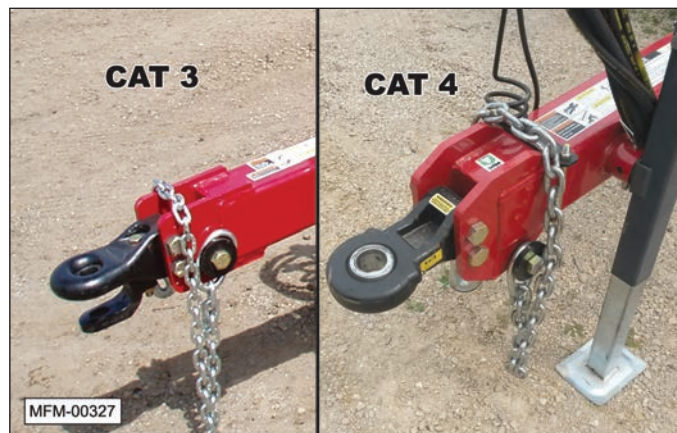

2. Connect the hitch of the unit to the tractor. Attach the tow chain to the tractor's draw bar cage.



**Note:** When connected, make sure the retaining plate securely locks the chain link in place.



3. Remove the jack stand and place it in its storage position inside the frame, as shown.





1. Remove the hydraulic hoses from their storage position.

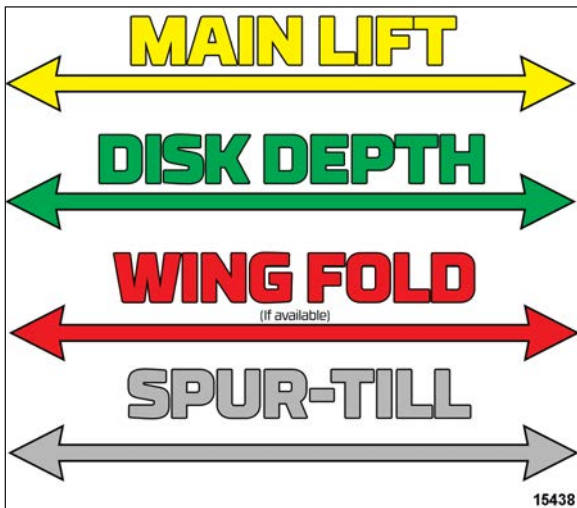

2. Connect the hydraulic hoses to the tractor.

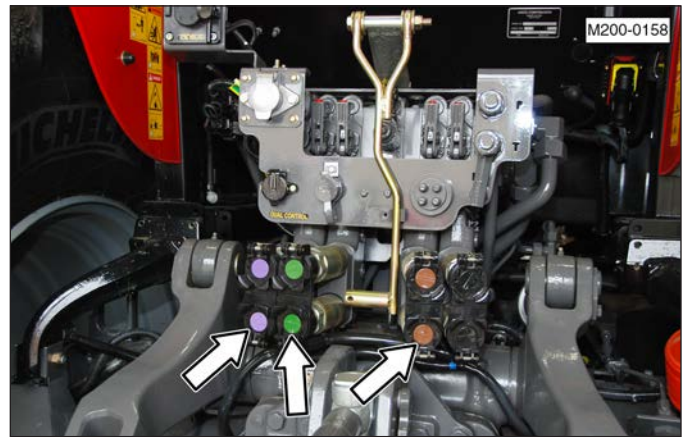

**Note:** The most commonly used function of the unit is the “main lift” cylinders, which raises and lowers the wheels. Connect the hydraulic hoses for this function into the port (control lever) used most commonly.

3. Disconnect the electrical connection for the rear lights from the storage socket.



a. Rotate the plug.



b. Push the plug upward and slightly rotate it again to release it from the socket.



c. Pull the plug downward.

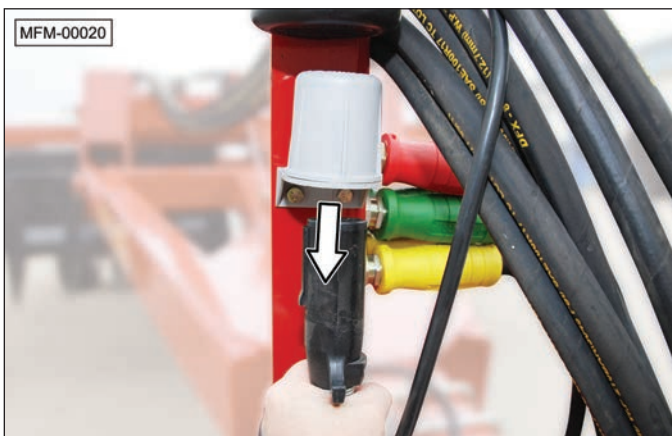

d. Connect the plug into the tractor's electrical socket.

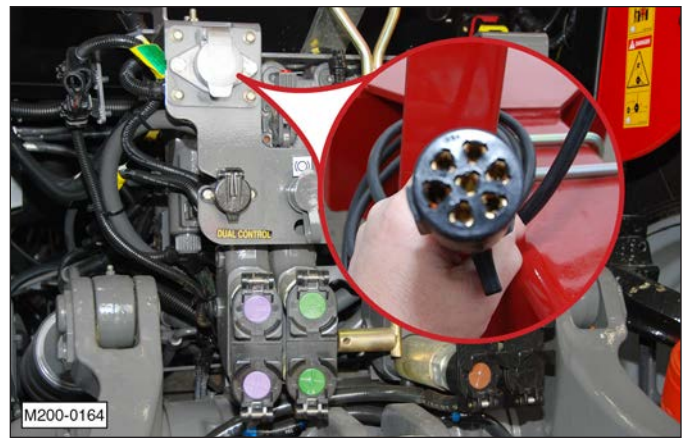

1. Make sure all the hydraulic cylinders are functioning properly.
2. Make sure the amber and red indicator lights are working properly.
3. Move the unit to the desired location and position it for operation following the towing recommendation provided in this manual and/or any other local, State, or Federal regulations that may apply.

## Operation

### Safety

#### **WARNING**

To prevent serious injury or death, follow these safety instructions



Entanglement Hazard  
**Keep hands and clothing clear of moving parts.**



Crush Hazard (Rolling Over)  
**Do not clean, lubricate, or make adjustments while the unit is moving.**



Crush Hazard (Rolling Over)  
**When making adjustments to the unit or leaving the operator's seat:**



1. Stop the tractor.
2. Shut off the engine and remove the ignition key.
3. Set the brakes.



Overturn Hazard  
**Pick the levellest possible route when transporting across fields. Avoid the edges of ditches or gullies and steep hillsides.**



Safe Distance  
**Keep all bystanders, pets, and livestock clear of the work area, particularly when raising or lowering the unit.**

#### **SAFETY INSTRUCTIONS**



**Periodically clear the unit of brush, twigs, or other materials to prevent buildup of dry, combustible materials.**

#### **NOTICE**

*DO NOT turn while the unit is in the ground.  
DO NOT operate the unit in frozen ground.*

## Initial Setup

The McFarlane Finalizer is a tool that is designed to handle a wide variety of field conditions. It has many adjustments that can be made to change the performance of each component on the unit as well as its overall performance. Achieving the best results over the widest range of circumstances can be accomplished by making adjustments to match the field conditions.

**Note:** It is important to make one adjustment at a time in order to see the results of each change. If several adjustments are made at the same time, the operation of the machine can change dramatically, creating confusion and frustration.

#### **WARNING**



Pinch Point Hazard  
**Do not place hands or fingers between moving and/or stationary parts. The weight of the unit will easily cause serious bodily injury.**



Sharp Object Hazard  
**Do not place any part of your body under the disk gang during the adjustment process. Severe injury will occur if a person contacts or falls under the disk gang.**

1. If equipped with wings, remove the wing fold lock pins and bridge pin and store them on the wing lock bracket.

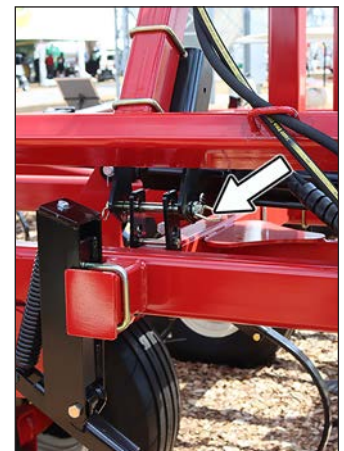
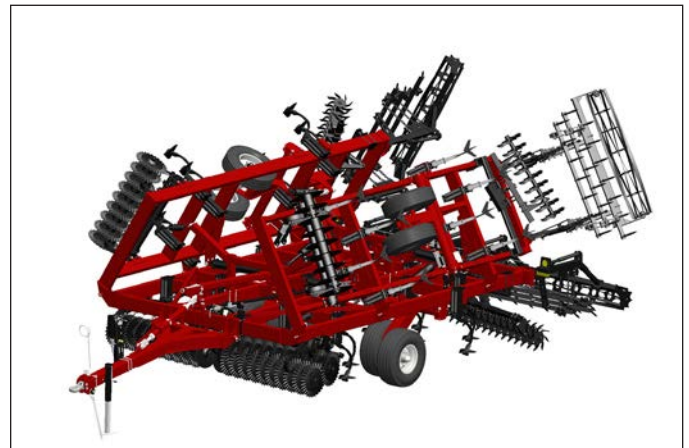

2. If necessary, raise the unit and release the transport locks from both wheel cylinders.
  - a. Remove the retainer clip.
  - b. Place the locks in their storage location on the wing side lock bracket and fasten with the retaining clip.



**Note:** As viewed from the front of the unit, turning the turnbuckle counterclockwise will raise the hitch end and lower the back end.

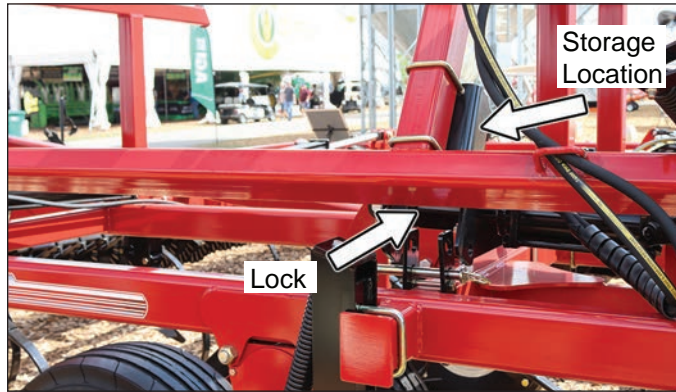

- a. Check the frame for levelness by verifying that all sweeps are contacting the ground.
- b. Once the unit is level from front to back, place the locking mechanism over the turnbuckle.

3. Move the unit to a level and smooth area.
4. Raise the disk gangs and Spur-Till to their maximum height.
5. Lower the unit until the sweeps are just touching the ground.



### Machine Leveling

Raise the locking mechanism from the turnbuckle.



Use the wrench (stored behind the hitch) to make the adjustment.

## Leveling Wing Frames

Level the wing frames. This prevents the sweeps from gouging and/or ridging. It also ensures a consistent operating depth across the width of the unit.

- a. Loosen jam nut and turn the adjusting nuts to raise or lower the wings. Repeat on other wing.
  - b. Run the unit in the ground a short distance and check the wing levelness and repeat adjustment if necessary.
1. Lower the unit into the ground and pull forward, stopping to check that all sweep are tilling to the same depth by brushing away the loosened soil.

### **WARNING**

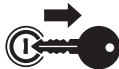

Before leaving the tractor, shut off the engine, set the parking brake, and remove the ignition key.

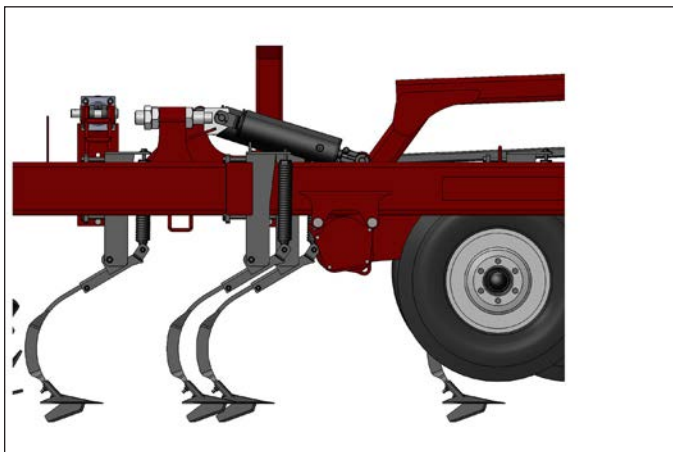

## Sweep Depth Adjustment

1. Adjust the depth of the sweeps using the single point depth stop at the front of the unit.
  - a. Lower the sweeps to the desired depth.
  - b. Turn the stop crank (depth control) to fully depress the pin on the hydraulic stop valve.
  - c. Pull the unit through the field and stop the unit without raising it.
  - d. Check the depth of the sweeps and adjust the stop crank accordingly.
  - e. If the sweeps need to be reset, turn the stop crank accordingly; two full turns of the crank equals 1 inch of depth adjustment.



1 Turn = 1/2"

 Deeper

**Note:** Since the wheels position the height of the entire frame of the unit, the depth setting of the other components also needs to be checked and possibly readjusted any time the sweep depth is changed.

## Disk Depth Adjustment

1. Pull the unit through the field with the sweeps in the ground and then lower the disk gangs until they start tilling the soil, approximately 3" deep. The disks are primarily for slicing residue and weeds. In uneven, tilled soil, it may be necessary to run the disk gangs deeper to improve soil leveling. In hard ground, run the disks more shallow to prevent the front sweeps from being lifted out of the ground.

### **WARNING**



Before leaving the tractor, shut off the engine, set the parking brakes, and remove the ignition key.

## Spur-Till Operation and Adjustment

The McFarlane Finalizer comes with a Spur-Till treader. It is designed to mix soil with residue, pulverize large clods, remove soil from exposed root balls and anchor residue to the soil surface.

**Note:** The Spur-Till comes assembled at 10 degrees.

The hydraulic cylinder support with constant down pressure is self-adjusting for unit depth and will maintain a uniform pressure over rolling terrain. As the unit is lowered, the Spur-Till will find its working position based on the set pressure applied. When the unit is raised the Spur-Till will lower to the maximum down position. We recommend hydraulically raising the Spur-Till for transport and going in and out of driveways or waterways.

### Operating with Constant Hydraulic Flow

1. The tractor SCV for the down pressure function must be set to constant hydraulic flow. Refer to your tractor manual to set your tractor hydraulics to this mode. This may also be referred to in your tractor manual as the setting required for hydraulic motors. If your tractor does not have this feature, the tractor SCV for the Spur-Till must be run in the float position. Make sure the tractor constant flow port is connected to the Finalizer gray grip that leads to the pressure reducing valve port just ahead of the gauge.
2. Lowering the flow rate to 25% of full flow will reduce the heat build up in the hydraulic oil.

### Spur-Till Depth Adjustment

1. Check the pressure gauge reading with the Finalizer connected to the tractor and operating in the constant flow mode. It should be set initially at 200 psi. To increase Spur-Till depth, the pressure can be increased by loosening the locking nut and rotating the knob clockwise. Be sure to lock the nut after finishing the adjustment. The pressure should not exceed 250 psi.

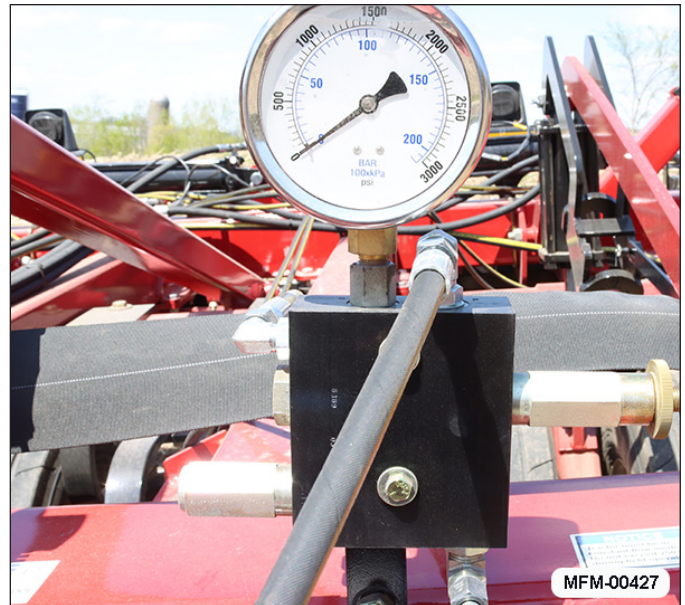

### Spur-Till Angle Adjustment

The Spur-Till can run at a 0° to 15° angle, and is set at 10° when delivered.

To adjust the angle of the Spur-Till, loosen both 3/4" bolts and manually rotate to the selected angle point.

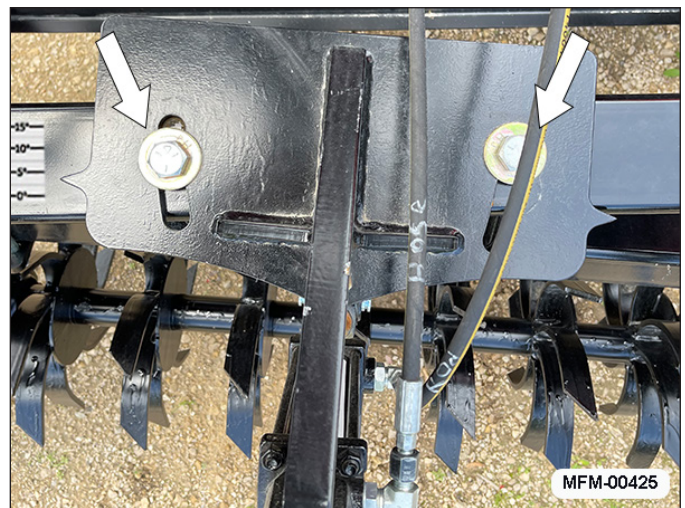

**Note:** When adjusting the Spur-Till to 0°, it is important to completely remove the bolt and place it the single hole on the pivot plate.

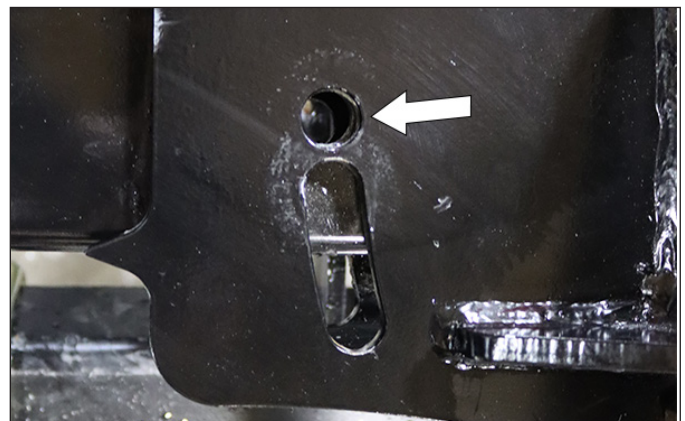

For residue pinning and soil firming, set the Spur-Till to 0°. When adjusting the Spur-Till to 0°, it is important to completely remove the bolt and place it the single hole on the pivot plate.

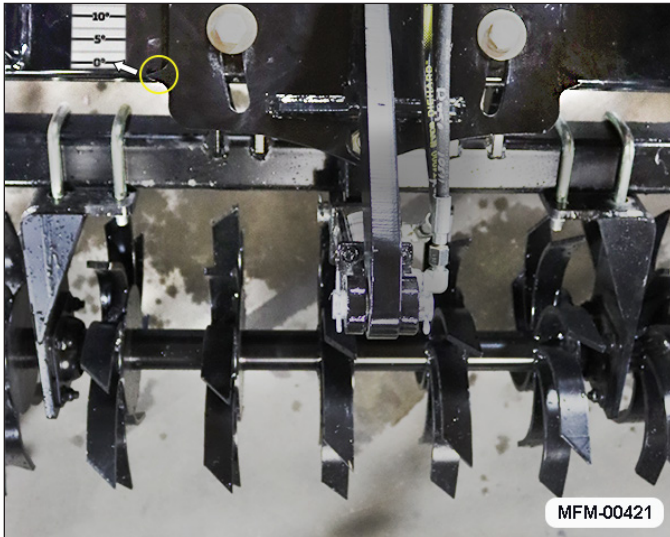

For minimal soil mixing, set the Spur-Till to 5°.



For increased root exposure, residue and soil mixing as well as residue incorporation, set the Spur-Till to roughly 10°.

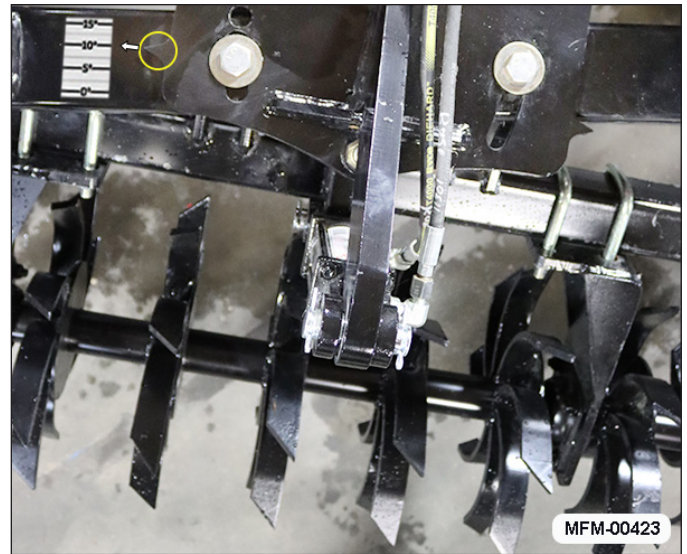

For maximum root exposure and soil mixing, set the Spur-Till to the steepest and most aggressive angle (15°).

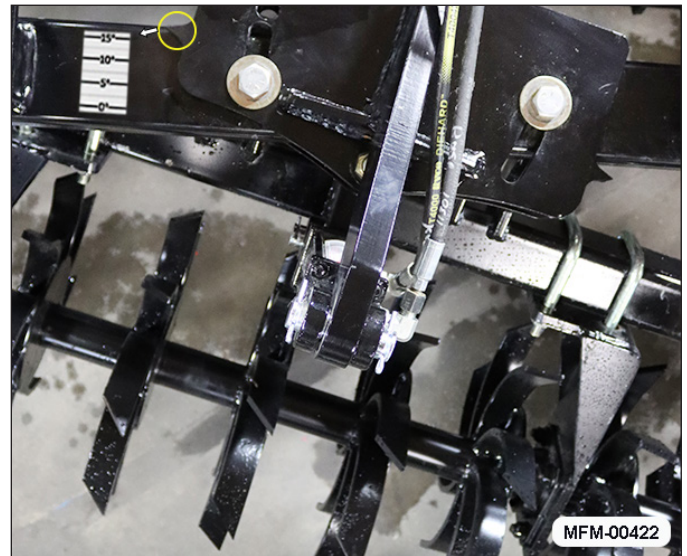

The unit should now be ready.

### Harrow and Rolling Basket Adjustment

1. Adjust the aggressiveness of the harrow sections. There are three attachment points on the first harrow bar to control the aggressiveness of the harrow.
  - a. In the least aggressive direction, mounting hole #1 will cause the sections to lay more flat (less aggressive).
  - b. In position #2, the teeth are in approximately a 45° position (more aggressive).
  - c. In position #3, the teeth are at the most aggressive angle (more upright).

**Note:** Typically, the angle should be set more aggressive for increased soil leveling and less aggressive in heavy residue conditions.

The steeper the angle of attack, the more aggressive the harrowing will be. In the least aggressive angle, use the pull hook in the top position, as shown.

In some situations that do not require the extra leveling of the harrow section, such as heavy fall residue, the sections can be removed or raised above the ground level.

2. Adjust the height of the harrow sections.

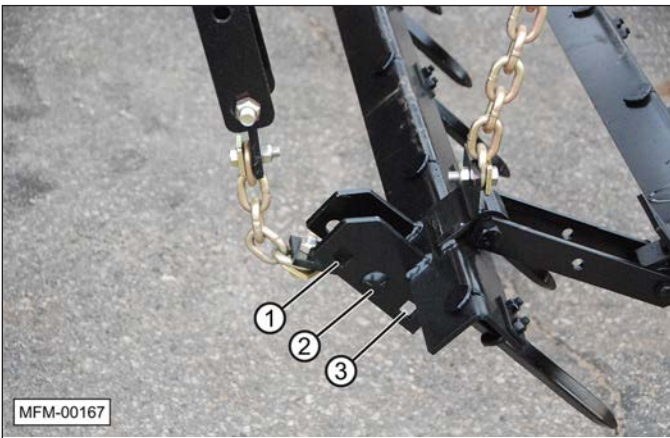

a. Remove the locking bar retainer clip.



b. Remove the locking bar.

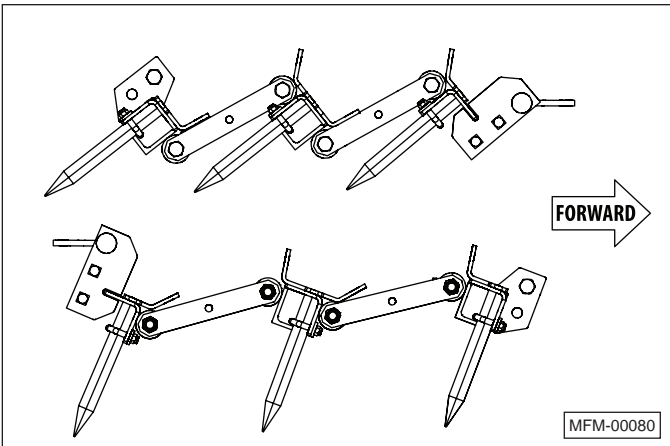

c. Raise or lower each harrow bar to the desired height.

Typical spring (finishing) settings are all three chains set with three links hanging.

Typical fall settings in heavy residue are front chain with seven links hanging, middle with six, and rear with five links hanging (front bar higher than rear bar).

**Note:** Make sure the chains are not twisted when inserting into the slot.

- d. Replace the locking bar and clip.

**Note:** To maximize the unit's performance, it should be operated at speeds ranging from 6 to 8 mph (9 to 13 kph). This keeps the field debris moving through the harrow sections and avoids clogging.

3. Adjust the rolling basket height and tension.
  - a. Place the rolling basket on a flat, level surface.
  - b. Adjust the turnbuckle to either raise or lower the rolling basket. To adjust the turnbuckle, use the wrench provided on the front of the unit.
  - c. Loosen the jam nut on the front of the turnbuckle, and turn the adjusting nut on the rear of the turnbuckle to raise or lower the rolling basket. Set the rolling basket height so it just touches the ground.



- d. Make sure all the rolling baskets are adjusted to the same height. Failure to do so will result in uneven seedbed conditions and could damage the rolling basket arms and/or bearings.
- e. If the spring or other components are replaced, tighten the adjusting nut to compress the spring 1/4". Make sure the jam nut is securely tightened against the adjusting nut.
- f. During operation the spring should only lightly compress. Too much spring tension will cause premature failure, especially when going through waterways or ditches.

## Preparing for Transport

1. Lower the wheels and lift unit off of the ground. Fold the wings into the wing rests.

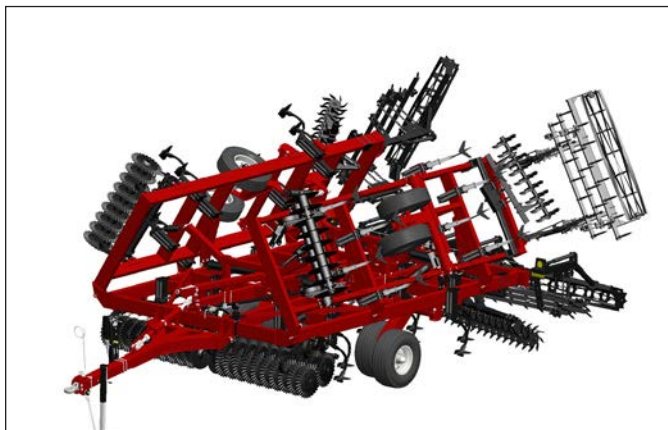
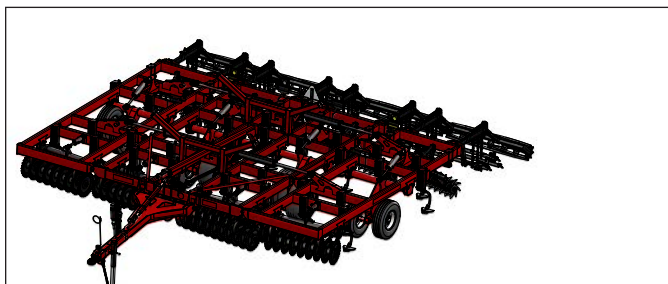

2. Install the wing fold lock pins and bridge pins.

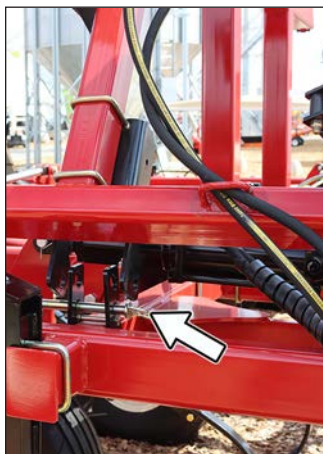

3. Remove the transport locks and place over the wheel lift cylinder rods. Insert and lock the retaining clip.



# Maintenance

## Safety

### **WARNING**

To prevent serious injury or death:

---



Rolling Over /  
Crush Hazard

To prevent serious

injury or death, before servicing, adjusting, repairing, or performing other work on the unit, always make sure the tractor or towing vehicle engine is stopped, the ignition key is removed, the unit is lowered to the ground, all controls are placed in neutral, the parking brake is set, and all hydraulic fluid pressure is relieved (zero pressure).

---



Rolling Over Hazard

**Block the wheels before performing maintenance or repairs.**

---



Use Properly Rated Tools

**Use sufficient tools, jacks, and hoists that have the capacity for the job.**

---



Crush Hazard

**Use support blocks or safety stands rated to support the load when changing tires or performing maintenance.**

---



High-Pressure Fluids

**Never use your hands to locate a hydraulic leak. Use a piece of**

**cardboard or wood. Wear proper hand and eye protection when searching for a high-pressure hydraulic leak.**

---

Hydraulic fluid escaping under pressure can penetrate the skin. Openings in the skin and minor cuts are susceptible to infection from hydraulic fluid. If injured by a concentrated high-pressure stream of hydraulic fluid, seek medical attention immediately. Without immediate medical treatment, serious infection or toxic reaction can develop if hydraulic fluid penetrates the surface of the skin.

---



Entanglement Hazard

**Keep hands, feet, clothing, jewelry, and long hair away from any moving parts to prevent them from getting caught.**

---

**SAFETY  
INSTRUCTIONS**

Follow all operating, maintenance, and safety instructions found in this manual.

 Understand the service procedure before performing the work. Keep area clean and dry.

 Replace all worn or damaged safety and instruction decals.

 Keep all parts in good condition and properly installed. Fix damage immediately. Replace worn or broken parts.

 Do not leave tools lying on the unit.



Do not modify machine or safety devices. Do not weld on the unit. Unauthorized modifications may impair its function and safety.

If equipment has been altered in any way from the original design, the manufacturer does not accept any liability for injury or warranty.



Never replace hex bolts with less than Grade 5 bolts unless otherwise specified. In locations where grade 8 bolts are used, grade 8 replacements are required.





Where replacement parts are necessary for periodic maintenance and servicing, genuine factory replacement parts must be used to restore the unit to original specifications. The manufacturer will not claim responsibility for damages as a result of the use of unapproved parts.

## Tire and Lug Torque Specifications

Model	Tire Size	Tire Pressure	Lug Size	Lug Torque (lb.ft.)		Tire and Wheel Weight
				Min	Max	
<b>MAIN FRAMES</b>						
FN-6024, FN-6029, FN-6032	IF 320/70R15 (4)	70	9/16"	85	100	159
<b>WING FRAMES</b>						
All Models	IF 280/70R15 (4)	64	1/2"	75	85	85

## Bolt Torque Chart

Bolt Head Markings	 No Marking		 3 Radial Lines		 6 Radial Lines	
	Bolt Diameter	SAE Grade 2 N·m (ft-lbs)		SAE Grade 5 N·m (ft-lbs)		SAE Grade 8 N·m (ft-lbs)
1/4"	8	(6)	12	(9)	17	(12)
5/16"	13	(10)	25	(19)	36	(27)
3/8"	27	(20)	45	(33)	63	(45)
7/16"	41	(30)	72	(53)	100	(75)
1/2"	61	(45)	110	(80)	155	(115)
9/16"	95	(70)	155	(115)	220	(165)
5/8"	128	(95)	215	(160)	305	(220)
3/4"	225	(165)	390	(290)	540	(400)
7/8"	230	(170)	570	(420)	880	(650)
1"	345	(225)	850	(630)	1320	(970)

## Maintenance Schedule

**Note:** Prior to each use, visually check for loose or missing bolts and replace lost or worn parts.

Refer to the Lubrication Location Drawing for a list of lubrication locations and frequency.

1. After the first 12 hours of use:

- a. Make sure all retaining hardware is installed. Check the tightness of all the bolts, especially those on the C-springs. Torque specifications are listed in the Bolt Torque Chart in this manual.

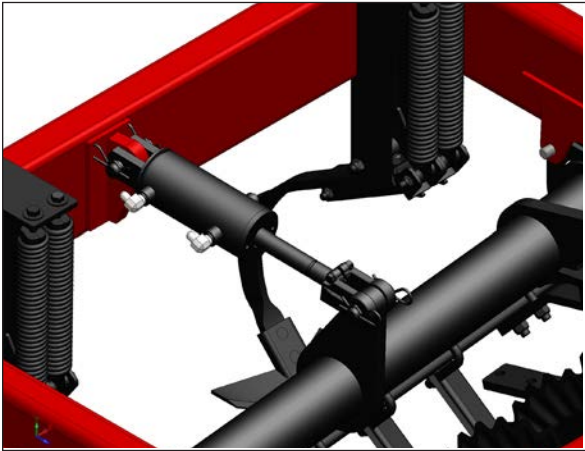

Cotter pins and clevis pins.

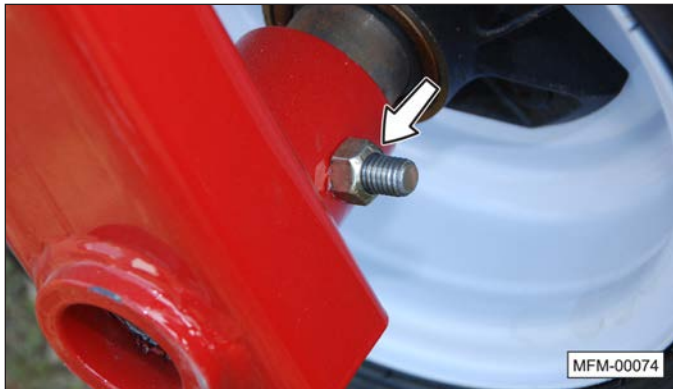

Wheel retainer bolts.

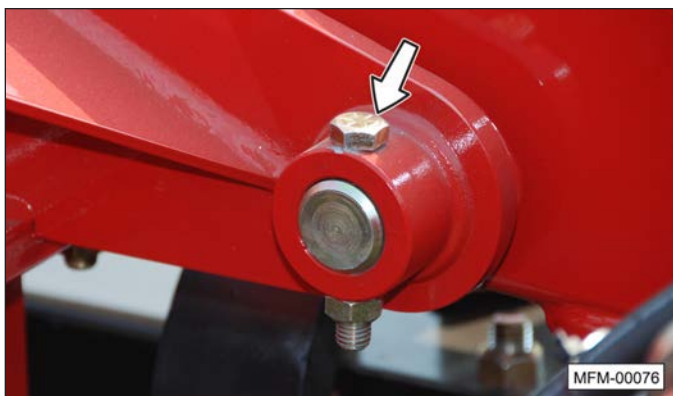

Hinge pin and hitch pin retainer bolts.



Bridge pins.

- b. Check the gang arbor bolt torque which is defined in the "Disk Gang and Blades" section.



- c. Inspect shank mount pivots for loose bolts and worn bushing inserts.

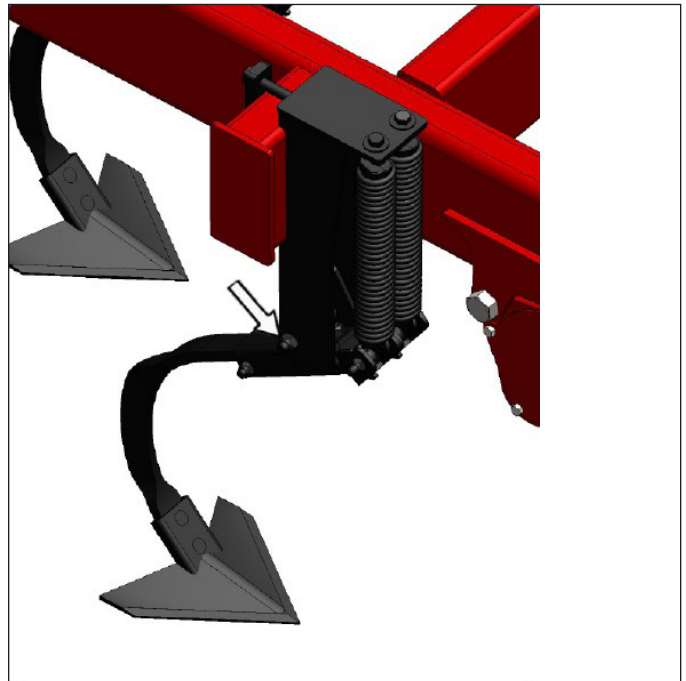

- Grease the oscillating pintle hitch daily while in service. Remove all vertical load from the hitch before greasing.



**Note:** Clean grease fittings and replace those that are broken or missing.

- Inspect the rubber bumper pads on the wing support arms. Replace the pads if they are worn or missing.



**Note:** Clean grease fittings and replace those that are broken or missing.

- Clean, repack, and adjust the wheel bearings annually. Use only wheel bearing grease when repacking these units. Check for excessive end play. To adjust wheel bearing, remove dust cap and cotter pin. Lift tire and slowly rotate while tightening the spindle nut. Tighten only until a slight drag is felt on the rotating wheel. Re-install cotter pin and dust cap.



- Refer to the parts illustrations and listings for service and repair parts.

**Note:** The level lift tube cushioning spring tension is set at the factory and should not be adjusted. If spring replacement becomes necessary, turn the adjusting nut until the compressed spring length is 8-3/16" and tighten the jam nut.

## Maintenance Procedures

### Wheel Lift Cylinders and Wing Cylinders

There are no setup procedures or maintenance items on these cylinders.

### Disk Gang Disk Blades

1. Replace the disk blades when the diameter is 19 inches or less.
2. It will also be necessary to check and tighten the disk gang arbor nuts to prevent excessive wear.
3. After 12 hours initial operation, using a torque-multiplier, tighten the gang arbor nuts to 1200-1600 ft-lb.

**Note:** A torque of 1200-1600 ft-lb would be equivalent to a 200 pound person using a 6 to 8 foot wrench.

**Note:** When reassembling the disk gang, it may be necessary to add a 1-3/4" machine washer (10656) in order to align the cross-drilled hole in the shaft with the slots in the castle nut.

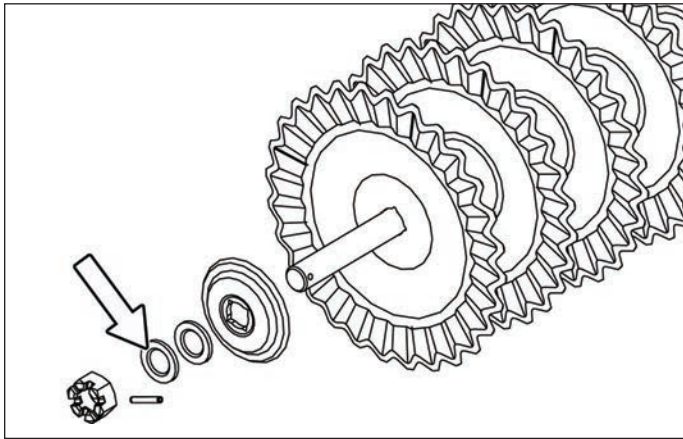

### For Spur-Till finishing configuration

1. Regularly inspect Spur-Till tines for damage and replace or repair as needed.
2. It will also be necessary to check and tighten the Spur-Till gang arbor nuts to prevent excessive wear.
3. After 12 hours of initial operation, using a torque-multiplier, tighten the gang arbor nuts to 800-1000 ft-lb.

**Note:** when disassembling Spur-Till gangs, note the orientation of all Spur-Till wheels (left vs. right), bearings, spacers and fasteners.

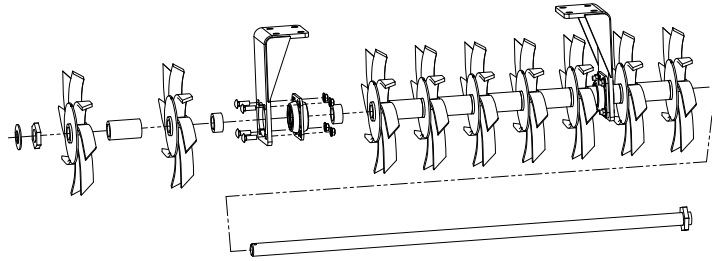

### Shank Spring and Pivot Bushing Replacement

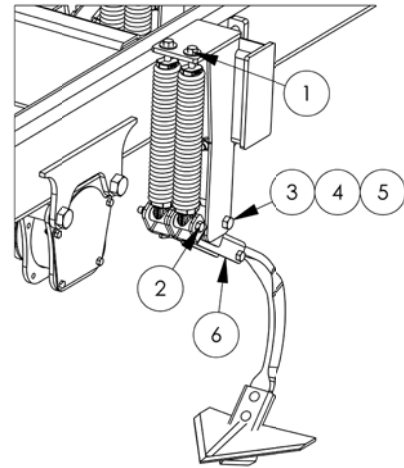

#### Spring Replacement

1. Remove the top spring bolt (1) and then remove the spring pivot bolt (2).
2. Remove the old spring and install the new one.

#### Pivot Bushing Replacement

1. Loosen the top spring bolt (1).
2. Remove the shank pivot bolt (3), plastic insert bushing (4) and pivot bushing (5).
3. Carefully tap the new plastic pivot bushing into the shank pivot bracket (6) with a rubber mallet.
4. Install the pivot bushing and secure with the pivot bolt.

## Axle Assembly Wear Sleeves



No maintenance is required on the four axle mounting bearings. Check for excessive wear annually. To replace the bearings:

1. Support the main frame.
2. Support the wheel assembly and wheel lift cylinders to relieve the pressure on the bearings.
3. Remove the bearing retainer caps (center bearings) and end caps (outer bearings).
4. Insert four new bearing wear sleeves. Do not replace just one sleeve.
5. Reinstall the retainers and caps.

## Lubrication Locations Drawing

Add grease to the locations shown in the photo on the following page.

When greasing a pin and bushing, add grease until it is visibly forced out of the joint.

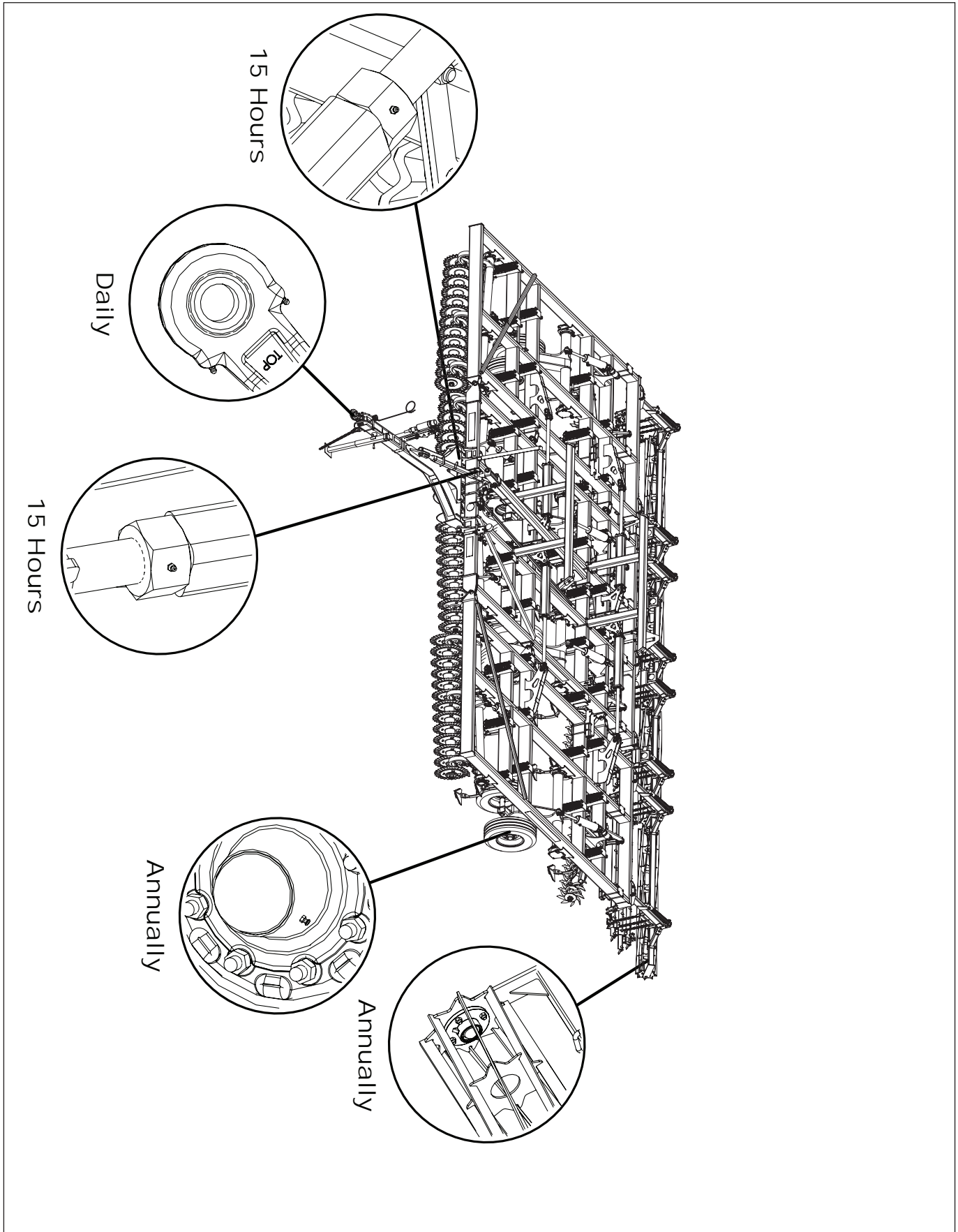

## Hydraulic Component Safety

### **WARNING**



#### Trapped Air Hazard

When installing, replacing, or repairing hydraulic system cylinders or parts, make sure that the entire system is charged and free of air before resuming operations. Failure to bleed the system of all air can result in improper machine operation, causing severe injury.



#### Zero Pressure

Relieve pressure from the hydraulic system before servicing or disconnecting from the tractor.



#### High-Pressure Fluid Hazard

Keep all hydraulic lines, fittings, and couplers tightly secured and free of leaks.



#### Explosive Separation Hazard

Replace any worn, cut, abraded, flattened, or crimped hoses.



#### High-Pressure Hazard

Do not make any temporary repairs to the hydraulic lines, fittings, or hoses using tape, clamps, or cement. The hydraulic system operates under extremely high pressure and temporary repairs may fail suddenly and create a hazardous/dangerous situation.



#### Personal Protection Equipment

Wear proper hand and eye protection when searching for a high-pressure hydraulic leak. Use a piece of wood or cardboard as a backstop instead of hands to identify and isolate a leak. If injured by a concentrated high-pressure stream of hydraulic fluid, seek medical attention immediately. Serious infection or toxic reaction can develop if hydraulic fluid penetrates the surface of the skin.



#### High-Pressure Fluid Hazard

Before applying pressure to the system, make sure all components are tight and that the hydraulic lines, hoses, and couplings are not damaged.

### **NOTICE**

Make sure components in the hydraulic system are kept clean and in good working condition.

## Tire Safety

### **WARNING**



#### Explosive Separation Hazard

Do not attempt to mount tires unless you have the proper equipment and experience to do the job. Failure to follow proper procedures when mounting a tire on a wheel or rim can produce an explosive separation, which may result in serious injury or death.



#### Explosive Hazard

Never weld or heat a wheel and tire assembly. The heat can cause an increase in air pressure, resulting in a tire explosion. Welding can structurally weaken or deform the wheel.



#### Flying Objects Hazard

Inflating or servicing tires can be dangerous. Whenever possible, trained personnel should be called to service and/or mount tires.

When inflating tires, use a clip-on chuck and extension hose. Always stand to the side of the tire when inflating, and NOT in front of or over the tire assembly.

Make sure the tires are inflated evenly.



#### Crush Hazard

Make sure the unit is completely supported with suitable stands before removing a wheel assembly.

### **SAFETY INSTRUCTIONS**



Always maintain the correct tire pressure. Do not inflate the tires above the recommended pressure.



Check tires for low pressure, cuts, bubbles, damaged rims, or missing lug bolts and nuts.



Always install tires and wheels with appropriate capacity to meet or exceed the weight of the unit.



Do not exceed 20 mph or tire failure will occur.



Keep wheel lug nuts or bolts tightened.

## Storage

### Safety

#### SAFETY INSTRUCTIONS

Follow all operating and safety instructions found in this manual when storing this equipment.



Store the unit in an area away from human activity.



Do not permit children to play on or around the stored unit at any time.

Make sure the unit is stored in an area with a firm and level base to prevent it from tipping or sinking into the ground.



Block the wheels to prevent the unit from rolling.

### Power wash the unit prior to storage, following this protocol:

1. Washing equipment: It is very important to read the instruction manual and test the machine on a small spot before starting the actual job. The scouring action of a pressure washer is very strong and may damage paint, and other surfaces if not properly used.
2. Nozzle Selection: Wide-fan nozzles are often preferred when pressure washing painted surfaces. Yellow (15-degree) or green (25-degree) fan nozzles are most common, white (40-degree) nozzles can also be used to clean unit.
3. Pressure Adjustment: To wash away dust and dirt, keep the pressure level between 1500 psi and 2000 psi. Pressures exceeding 2000 psi may damage paint depending on nozzle size and how close nozzle is to the part.
4. Wand angle: To avoid damaging painted surfaces, keep the wand angle/nozzle at a 45-degree angle and spray from a minimum distance of 12 inches. If you increase the pressure, move the nozzle further away from the surface.
5. Scrub away persistent dirt: Use a rotating scrub brush or a sponge along with a mild detergent solution to remove stubborn stains.

### Placing Into Storage (Disk Coatings)

Apply a thin layer of grease to all exposed metal surfaces of the disks, reel, and reel blades.

### Disposal of Equipment at End of Useful Life

The McFarlane Finalizer has been designed for the specific purpose of tilling agricultural farm land. When this unit is no longer capable of doing its designed purpose, it should be dismantled and scrapped. Do not use any materials or components from this unit for any other purpose.

## Warranty

### Limited Warranty Statement

FULL ONE YEAR WARRANTY

If within one year from the date of purchase, this Finalizer fails due to a defect in material or workmanship, McFarlane Mfg. Co., Inc. will repair it, free of charge.

Warranty service is available at dealer locations by simply contacting the nearest McFarlane dealership throughout the United States or Canada.

This warranty applies only while this product is used in the United States or Canada.

This warranty gives you specific legal rights, and you may have other rights which vary from state-to-state.

### Serial Number Location



## Troubleshooting

Problem	Cause	Solution
Sweeps at the front of the unit are not tilling at the same depth as the sweeps at the rear of the unit.	Disk gang is set too deep. Hard, compacted soils may limit disk blade depth.	Decrease the disk gang operating depth.  Whenever you are making a change to any setting, make sure the unit remains level as it is pulled through the field.
	Unit is out of level fore/aft.	Use the hitch turnbuckle to level the unit front to back. Follow the instructions for machine leveling.
Unit leaves large soil clods.	Sweeps too deep in wet, heavy soil.	Decrease sweep depth.
	Spur-Till not aggressive enough.	Increase down pressure and/or increase operating angle.
Unit leaves surface uneven in loose soil.	Sweeps not deep enough when running in uneven field conditions.	Lower the sweeps, not to exceed the 5" maximum operating depth.
	Disk gang not set deep enough.	Increase disk operating depth to level more soil.
	Spur-Till not aggressive enough.	Increase down pressure and/or increase operating angle.
Wing frame section not working to desired depth.	Wing frame is set too shallow.	Level the wing frame using the adjustments on the wing wheels to raise the outside of the disk gang. Follow the instructions in the machine leveling section.
Outside disk gang gouges.	Wing frame is set too deep.	Level the wing frame using the adjustments on the wing wheels to raise the outside of the disk gang. Follow the instructions in the machine leveling section.
Spur-Till plugs in wet soil conditions.	Too much down pressure.	Decrease the down pressure using the adjustable valve at the front of the unit. Follow the instructions in the Spur-Till adjustment section.  The Spur-Till can be run in float or raised completely out of the ground to further increase the ability to handle tough conditions.
The residue is not being sized correctly.	The front disk gang may not be set deep enough.	Increase the depth of the disk gang up to a 4" maximum depth.  Whenever you are making a change to any setting, make sure the unit remains level as it is pulled through the field.
Residue buildup on harrow bars.	The harrow bar height is not set correctly.	Adjust the lift chains to raise the harrow bar to allow more residue to flow through. Follow the instructions for setting the harrows in heavy residue in the harrow and rolling basket adjustment section.
	The harrow bar angle is too aggressive.	Adjust the pull chains to allow for more residue clearance. Follow the instructions for adjusting the aggressiveness in the harrow and rolling basket adjustment section.
Rolling basket springs are breaking.	Too much spring tension.	Raise the rolling baskets by following the instructions in the harrow and rolling basket adjustment section.

## Parts Section

### Ordering Parts

We manufacture a quality product that requires very little maintenance or repair. However, should a part break or become damaged, our knowledgeable staff can make sure you receive the part(s) to put your unit back into operation.

### Dealer Contact Information

For replacement decals, questions, or to order parts, contact your dealer:



## Decals

 **WARNING**



**Make sure all decals are attached to the unit and are legible at all times. Safety decals and reflective tape provide a vital role in helping to reduce injuries and/or possibly even death.**

---

To ensure the greatest level of safety, all decals must be in place and legible at all times. Remember, it is the user's responsibility to maintain these decals.

# Parts Drawings

## Hitch Frame for FN-6000 Series

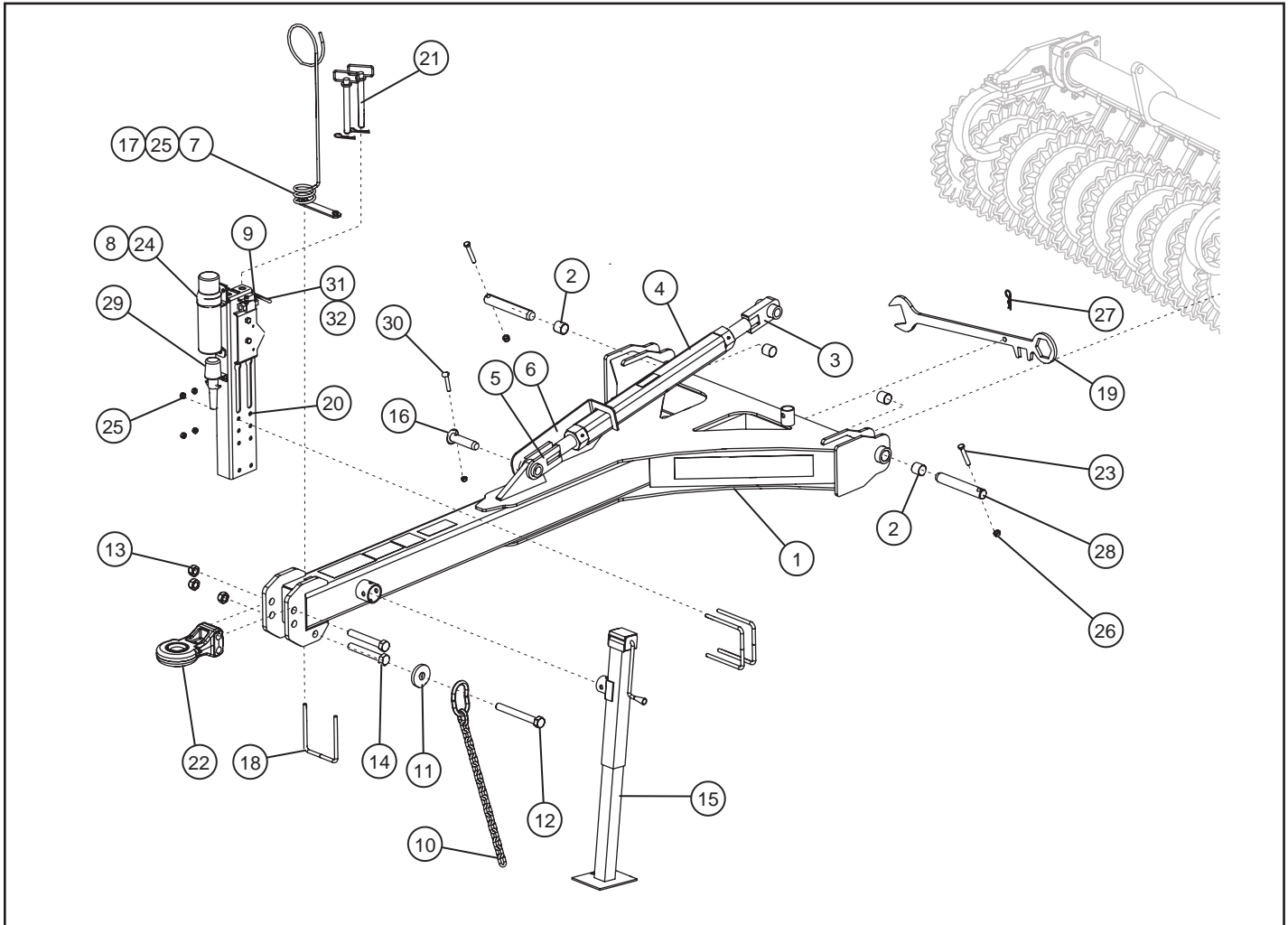

Item	Part Number	Description
1	15432	HITCH FRAME
2	RD-4889	WING AXLE BUSHING
3	RT-2112-02	PIVOT END THREADED ROD
4	RT-3145	LINK, TURNBUCKLE
5	RT-2111	YOKE, TURNBUCKLE
6	11952	LOCK, TURNBUCKLE, 3"
7	12054	MOUNT, HOSE WHIP
8	BH-2510	BOLT, HEX, 1/4-20X1, GD5
9	BH-2520	BOLT, HEX, 1/4-20X2, GD5
10	CH-1830	SAFETY CHAIN 30,400 lbs
11	RT-3103	SAFETY CHAIN WASHER
12	BHY-1085	BOLT, HEX, 1-8X8.5, GD8
13	NLT-1008	NUT, LOCK, TOP, 1-8
14	BHY-1070	BOLT, HEX, 1-8X7, GD8
15	QT-1243	JACK, SIDEWIND, 15", 8000#
16	RT-2113	TURNBUCKLE PIN ASSY

Item	Part Number	Description
17	12735	HOSE WHIP
18	BU-1267	U-BOLT, 1/2 X 6 X 7 1/4
19	10273	ADJUSTMENT WRENCH
20	14492	BRACKET, STORAGE, HITCH
21	PH--8860	HITCH PIN, 7/8 x 6 w/#6 BRIDGE PIN
22	12336	HITCH PINTLE, ARTICULATING BALL
23	BHY-5635	9/16-12 X 3-1/2 GRADE 8 BOLT
24	14493	MANUAL STORAGE TUBE
25	NLT-5013	NUT, LOCK, HEX, 1/2-13
26	NLT-5612	9/16-12 TOP LOCK NUT
27	PB-0009	BRIDGE PIN #9
28	RT-2107	HINGE PIN, 1-1/2 X 9-5/8
29	LB1110	LIGHT PLUG STORAGE
30	BH5028	1/2 X 2-3/4 GRADE 5 HEX BOLT
31	NLT-4414	7/16 TOP LOCK NUT
32	LW-0025	1/4 LOCK WASHER

## Level Lift for FN-6000 Series

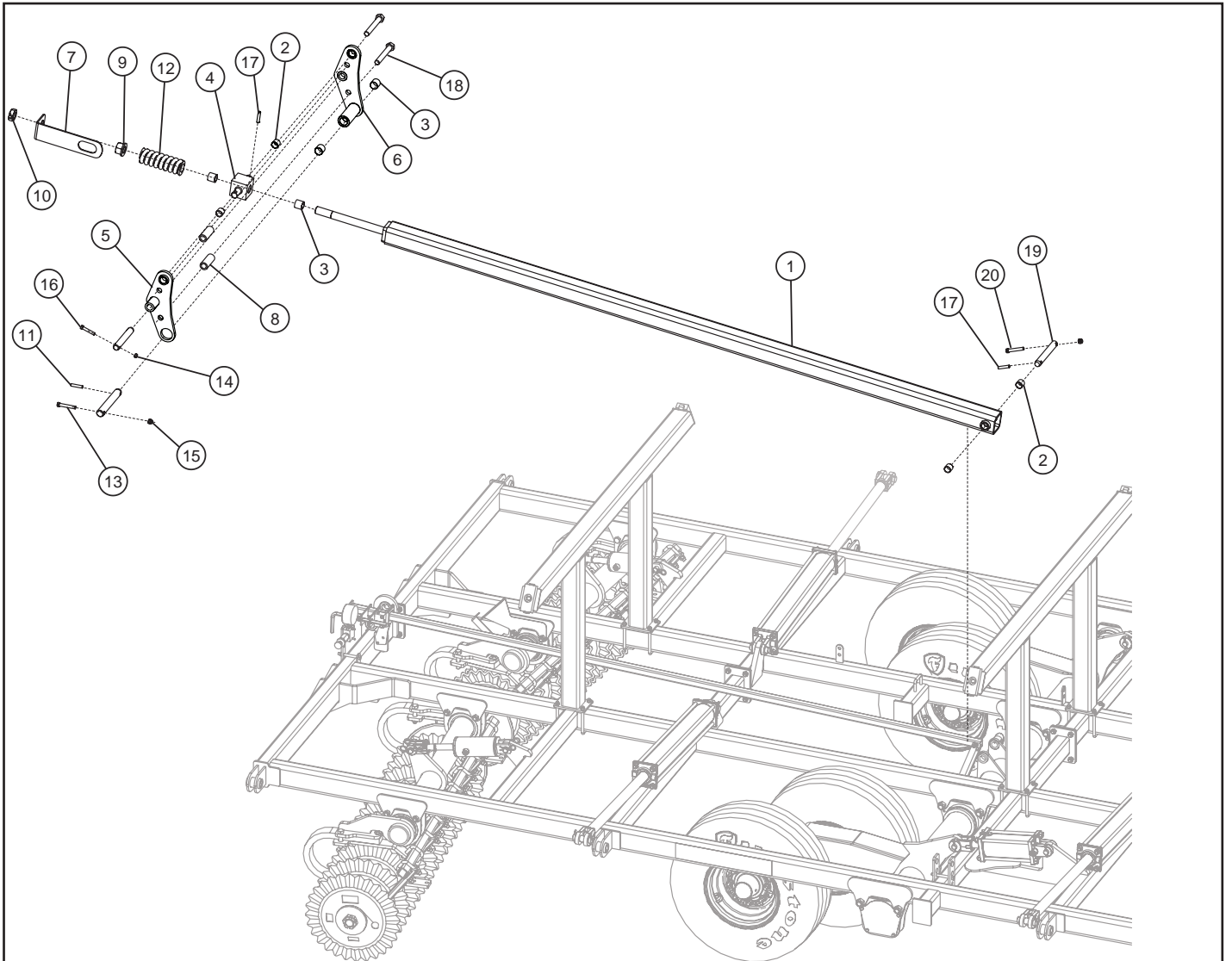

Item	Part Number	Description
1	14264	TUBE, LEVEL LIFT
2	10691	BUSHING, PLASTIC
3	RD-4889	WING AXLE BUSHING
4	10607	LEVEL LIFT BLOCK
5	10613	LEVEL LIFT PIVOT PLATE ASSY LH
6	10260	LEVEL LIFT PIVOT PLATE ASSY RH
7	11331	STRAP
8	10944	HITCH DOM
9	NHF-1506	NUT, FLANGE, 1 1/2
10	11986	NUT, JAM, 1.5-6 W SET SCREW

Item	Part Number	Description
11	10283	PIN, 1.50 X 10.31
12	10615	SPRING, COMPRESSION
13	BHY-5635	BOLT, HEX, 9/16 X 3 1/2, GD8
14	NLT-5013	NUT, LOCK, TOP, 1/2-13
15	NLT-5612	NUT, LOCK, TOP, 9/16-20
16	QT-1180	PIN, STRAIGHT
17	RD-5062	PIN, SPRING ROLL, 1/2 X 25
18	BHY-1070	BOLT, HEX, 1-8X7, GD8
19	10684	PIN, 1.25 X 9.81
20	BHY-5635	BOLT, HEX, 9/16 X 3 1/2, GD8

## Main Frame and Axle for FN-6000 Series

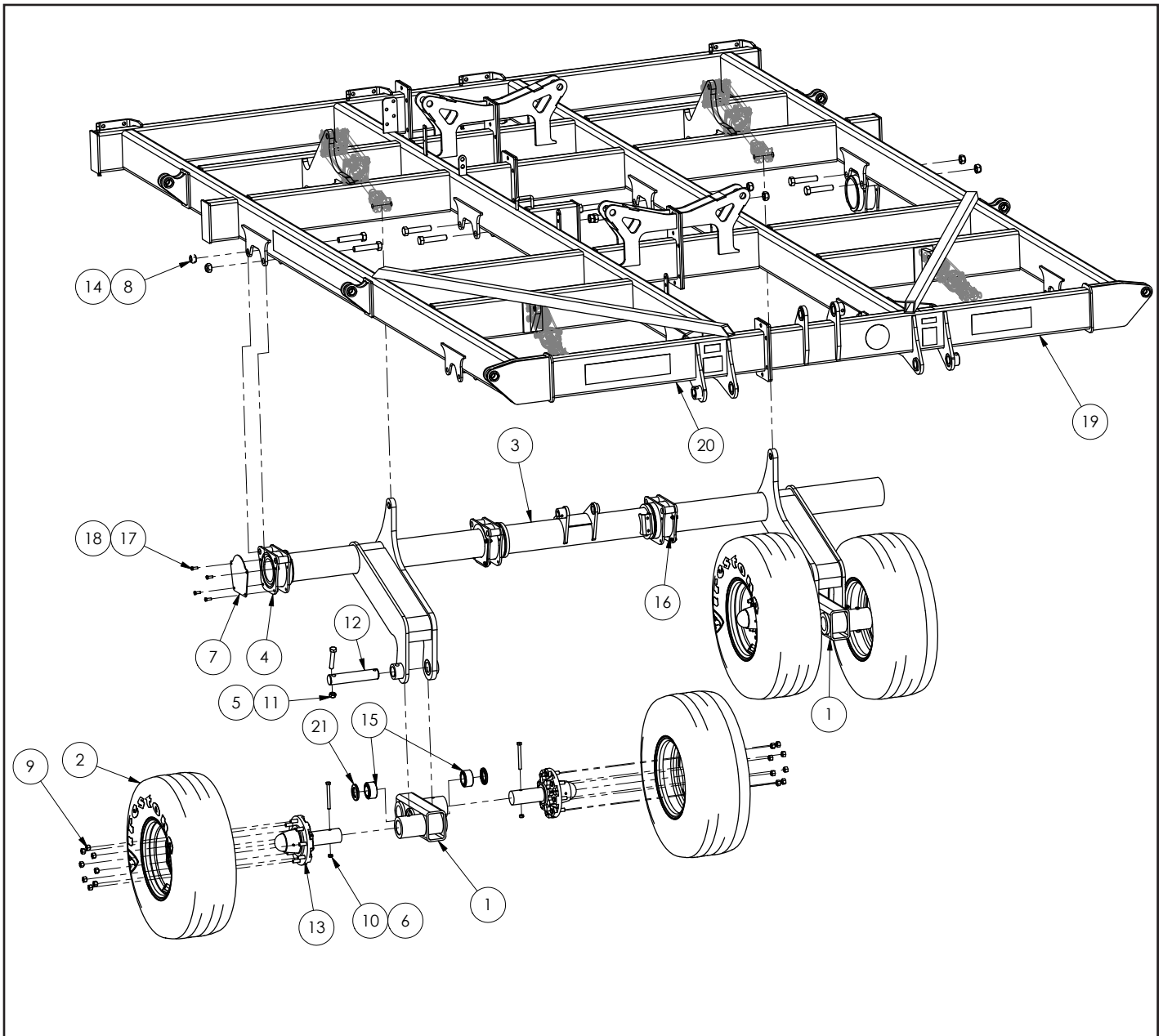

Item	Part Number	Description
1	15233	AXLE, WALKING TANDEM, RT
2	12616	ASM, TIRE/RIM, IF320/70R15
3	14266	AXLE, MAIN FINISHER
4	14269	BRACKET, AXLE MOUNT
5	BH-7540	BOLT, HEX, 3/4-10X4, GD5
6	BH-5050	BOLT, HEX, 1/2-13X5, GD5
7	14525	RETAINER, AXLE MOUNT BRKT
8	NLT-1008	NUT, LOCK, TOP, 1-8
9	WN-0063	WHEEL NUT, 5/8
10	NLT-5013	NUT, LOCK, TOP, 1/2-13
11	NLT-7510	NUT, LOCK, TOP, 3/4-10

Item	Part Number	Description
12	13938	PIN, STRAIGHT
13	RT-3185	HUB W SPINDLE, 2-3/4X12-1/2, 8-BOLT HD
14	BH-1050	BOLT, HEX, 1-8 3X5, GD5
15	13231	BEARING, SEALED
16	QT-1173	AXLE MOUNT UHMW INSERT, SPLIT
17	BH-3813	BOLT, HEX, 3/8-16X125, GD5
18	NLT-3816	NUT, HEX, 3/8-16
19	14214	FRAME, MAIN, LT
20	14255	FRAME, MAIN, RT
21	16936	SEAL

## Depth Stop for FN-6000 Series

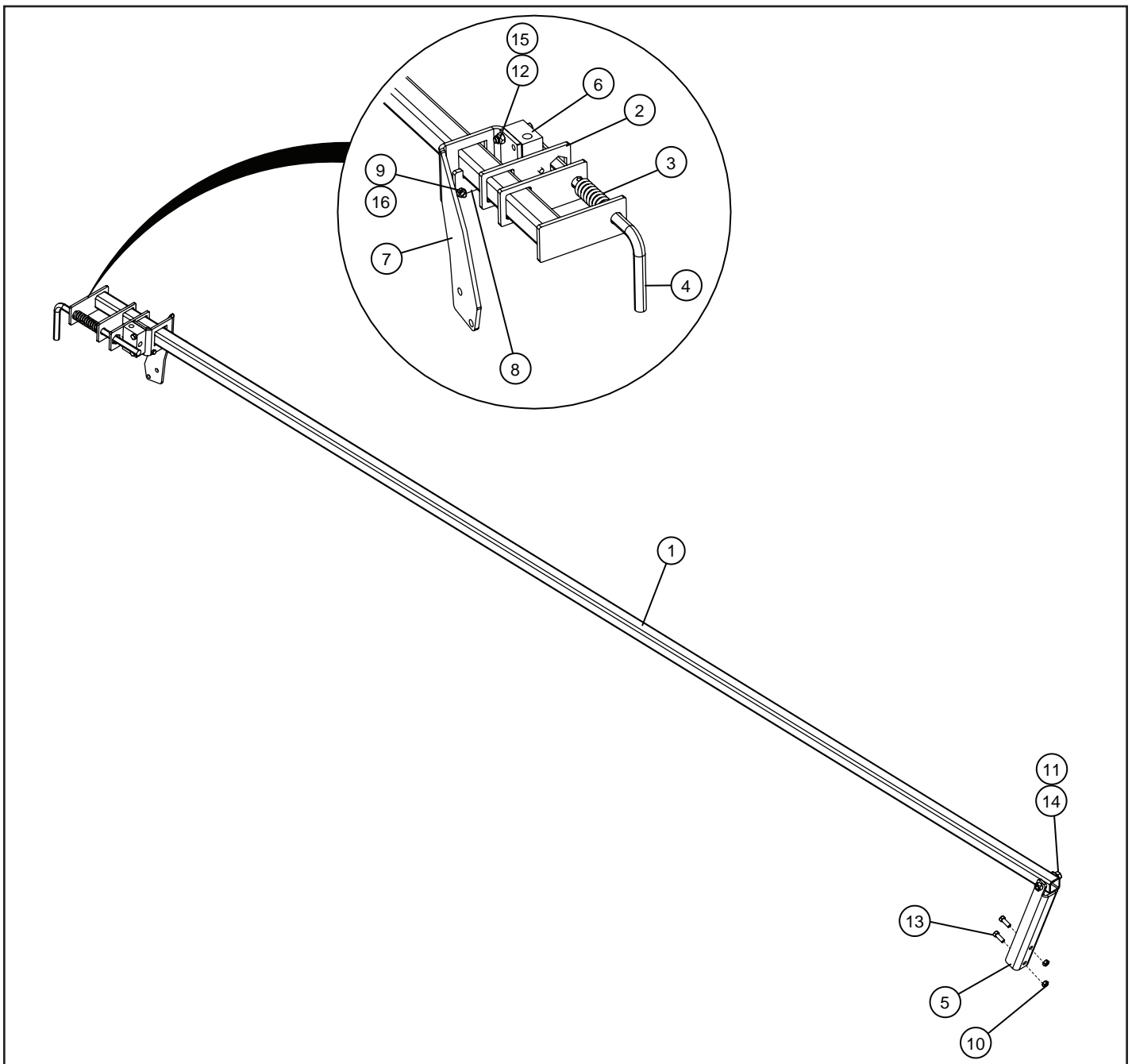

Item	Part Number	Description
1	14288	TUBE, DEPTH STOP
2	RD-4353	PLATE, STOP
3	RD-4355	SPRING, COMPRESSION, 1X3.5X.162
4	RD-4354	HYD STOP CRANK, RD
5	QT-1139	CHANNEL, BRACKET
6	HYO-3021	HYD STOP VALVE, RESTRICTED
7	11753	VALVE MOUNT
8	11759	PLASTIC, WEAR PAD

Item	Part Number	Description
9	NLT-2520	NUT, LOCK, TOP, 1/4-20
10	NLT-3816	NUT, LOCK, TOP, 3/8-16
11	NLT-5013	NUT, LOCK, TOP, 1/2-13
12	NY-3118	NUT, NYLON, 5/16
13	BH-3810	BOLT, HEX, 3/8-16X1, GD5
14	BH-5028	BOLT, HEX, 1/2-13X2.75, GD5
15	BH-3120	BOLT, HEX, 5/16-18X2, GD5
16	BH-2510	BOLT, HEX, 1/4-20X1, GD5

## Shank Assembly for FN-6000 Series

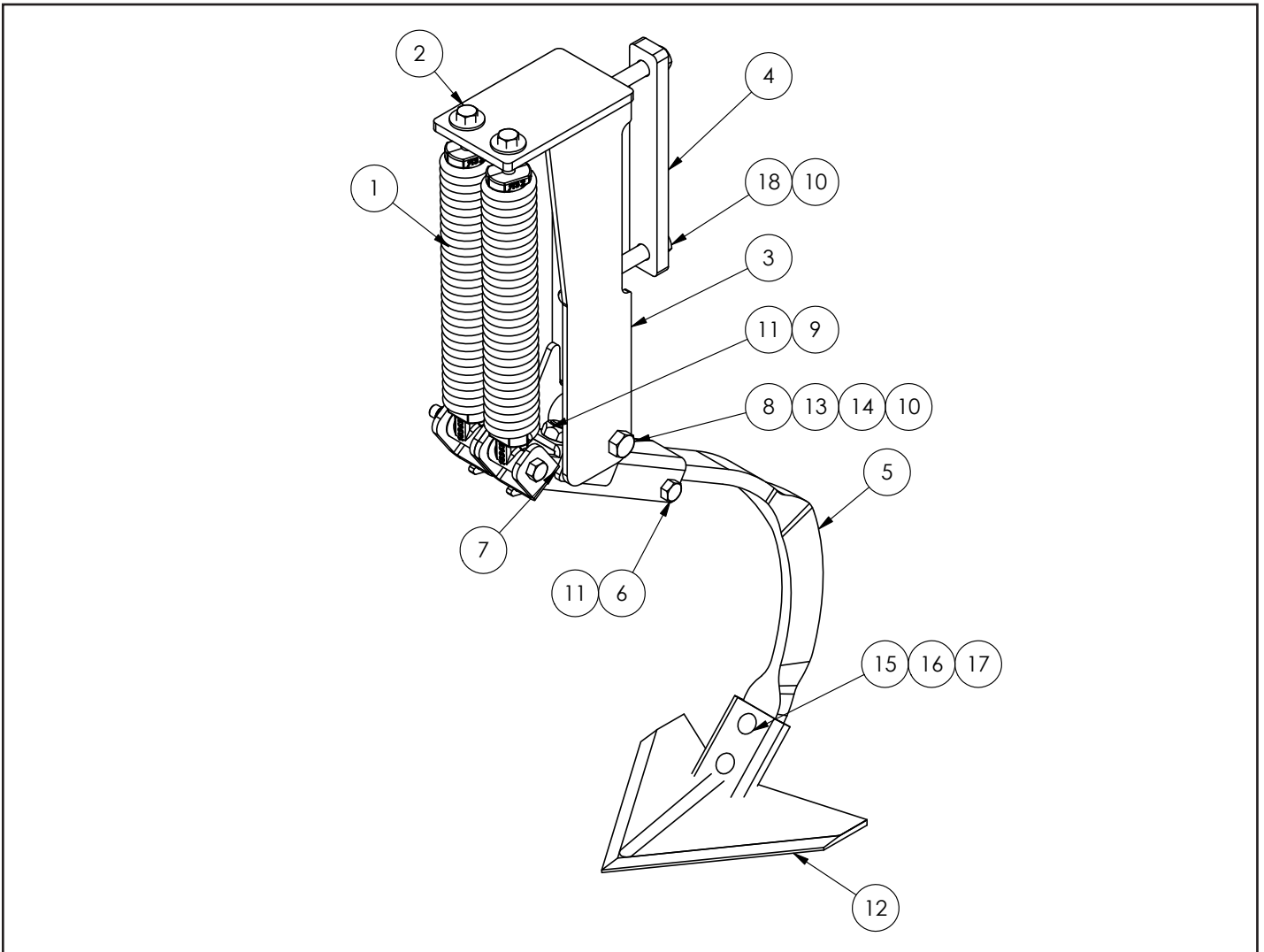

Item	Part Number	Description
1	14194	ASSY, EXTENSION SPRING
2	BH-5018	BOLT, HEX, 1/2-13X1.75, GD5
3	14258	BRACKET, SHANK MOUNT
4	16583	PLATE, CLAMP, SHANK MOUNT
5	16979	SHANK,CULTIVATOR,EDGE-ON
6	BHY-5030	BOLT, HEX, 1/2-13X3, GD8
7	14262	BRACKET
8	BHY-6345	BOLT, HEX, 5/8-11X4.5, GD8
9	BH-6315	BOLT, HEX, 5/8-11X1.5, GD5
10	NLT-6311	NUT, LOCK, TOP, 5/8-11

Item	Part Number	Description
11	NLT-5013	NUT, LOCK, TOP, 1/2-13
12	14657	SWEEP, BOLT ON, 10"
	14704	SWEEP, QUICK-CHANGE, 10" (INCLUDES BRACKET AND RETAINER SPRING)
13	10716	TUBE, ROUND
14	10710	BUSHING, PLASTIC
15	14824	PLOW BOLT, 7/16-14X1.75, GD5
16	FW-0044	WASHER,FLAT,7/16
17	NLT-4414	NUT, LOCK, TOP, 7/16-14
18	BH-6350	BOLT, HEX, 5/8-11X5, GD5

## Wing Rest for FN-6000 Series

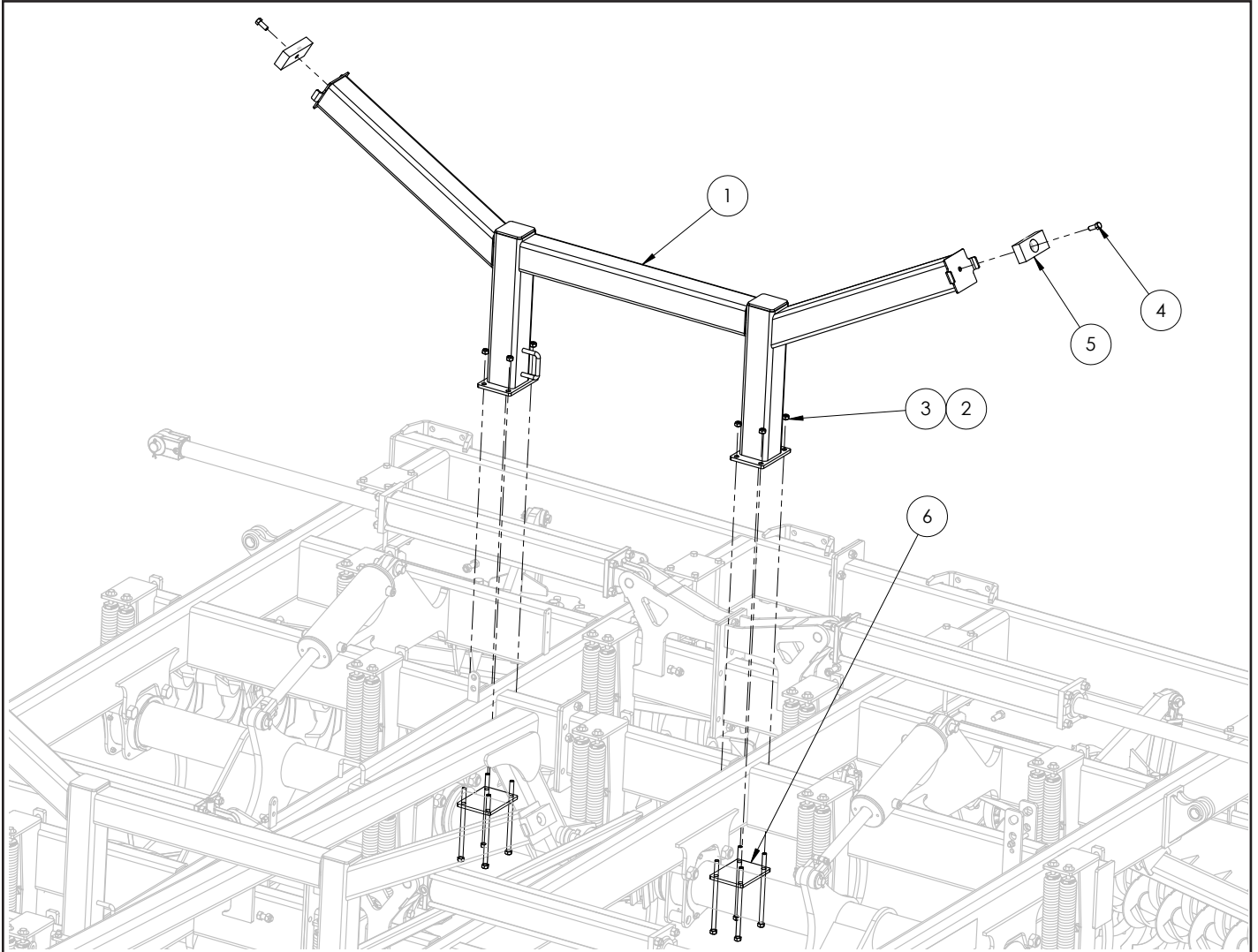

Item	Part Number	Description
1	14311	BRACKET, WING REST (FN-6029, FN-6032)
	17163	BRACKET, WING REST (FN-6024)
2	BH-5095	BOLT, HEX, 1/2-13X9.5, GD5
3	NLT-5013	NUT, LOCK, TOP, 1/2-13
4	RT-3415	RUBBER BUMPER
5	BH-5013	BOLT, HEX, 1/2-13X1.25, GD5
6	14300	PLATE, CLAMP

## Wing Frame and Axle for FN-6000 Series

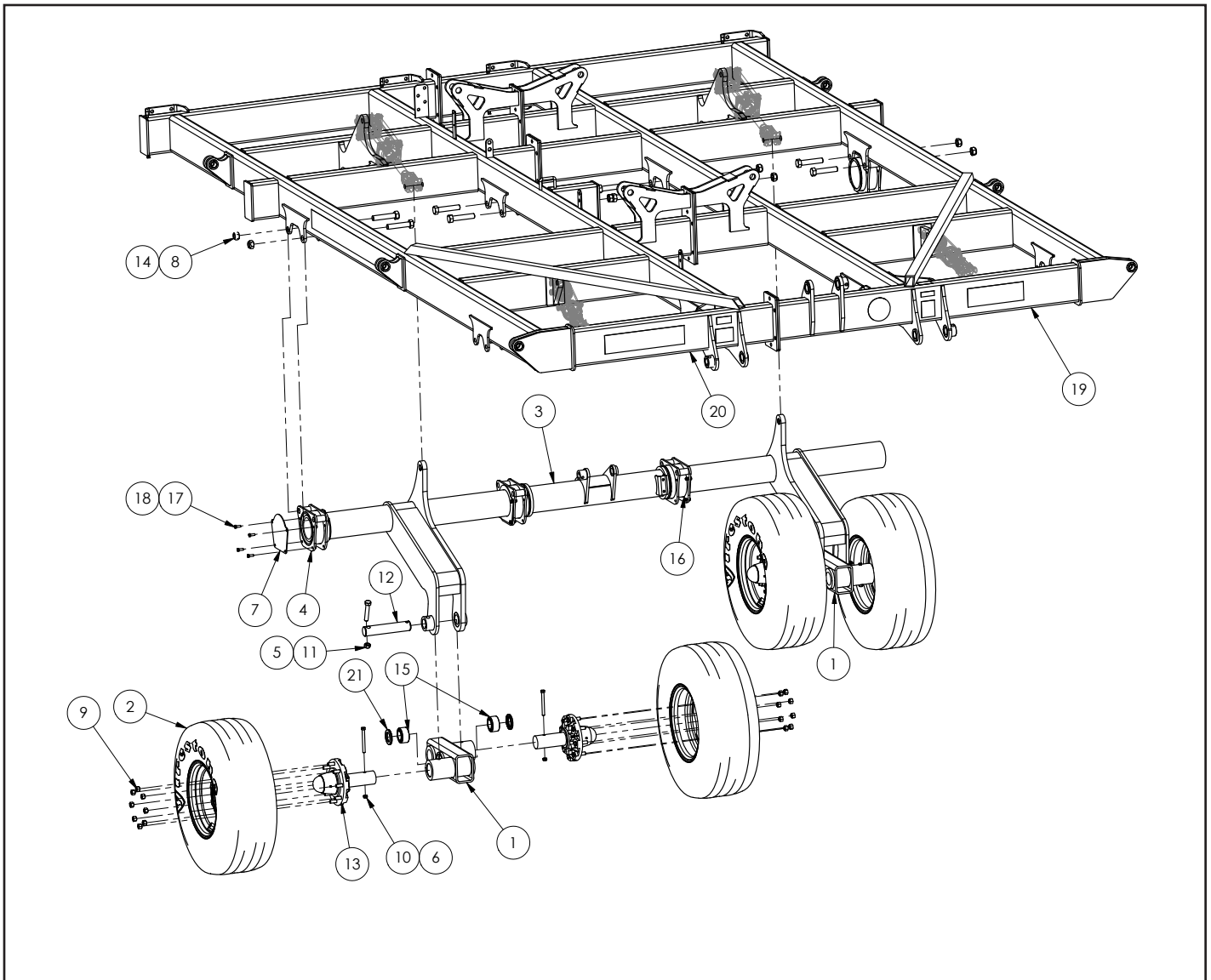

Item	Part Number	Description
1	14236	FRAME, WING, LT (FN-6029)
	14237	FRAME, WING, RT (FN-6029)
	14532	FRAME, WING, LT (FN-6024)
	14533	FRAME, WING, RT (FN-6024)
	14534	FRAME, WING, LT (FN-6032)
	14535	FRAME, WING, RT (FN-6032)
2	WDL-2507	HUB W/SPINDLE, 1-3/4X9-1/2, 6-HOLE
3	14585	AXLE, WALKING TANDEM, LT
	14711	AXLE, WALKING TANDEM, RT
4	14273	AXLE, WING, LT
	14275	AXLE, WING, RT
5	QT-1150	BUSHING, SPRING
6	16936	SEAL
7	NLT-5013	NUT, LOCK, TOP, 1/2-13
8	13231	BEARING,SEALED
9	10696	PIVOT POST, ADJUSTABLE
10	QT-1277	DISK HITCH PIN, 1-1/4

Item	Part Number	Description
11	14269	BRACKET, AXLE MOUNT
12	NLT-3816	NUT, LOCK, TOP, 3/8-16
13	BH-3810	BOLT, HEX, 3/8-16X1, GD5
14	WB-5010	WHEEL BOLT, 1/2X1.25
15	BH-1050	BOLT, HEX, 1-8X5, GD5
16	NLT-1008	NUT, LOCK, TOP, 1-8
17	BH-5025	BOLT, HEX, 1/2-13X2.5, GD5
18	NLT-5013	NUT, LOCK, TOP, 1/2-13
19	BH-5035	BOLT, HEX, 1/2-13X3.5, GD5
20	12490	TIRE, IF280/70R15
21	HD-1368	RIM, 15X8, 6-BOLT, 2900LB
22	13938	PIN, STRAIGHT
23	BH-7540	BOLT, HEX, 3/4-10X4, GD5
24	NLT-7510	NUT, LOCK, TOP, 3/4-10
25	14525	RETAINER, AXLE MOUNT
26	NHJ-2005	NUT, JAM, 2

## Disk Mount and Scrapers for FN-6000 Series

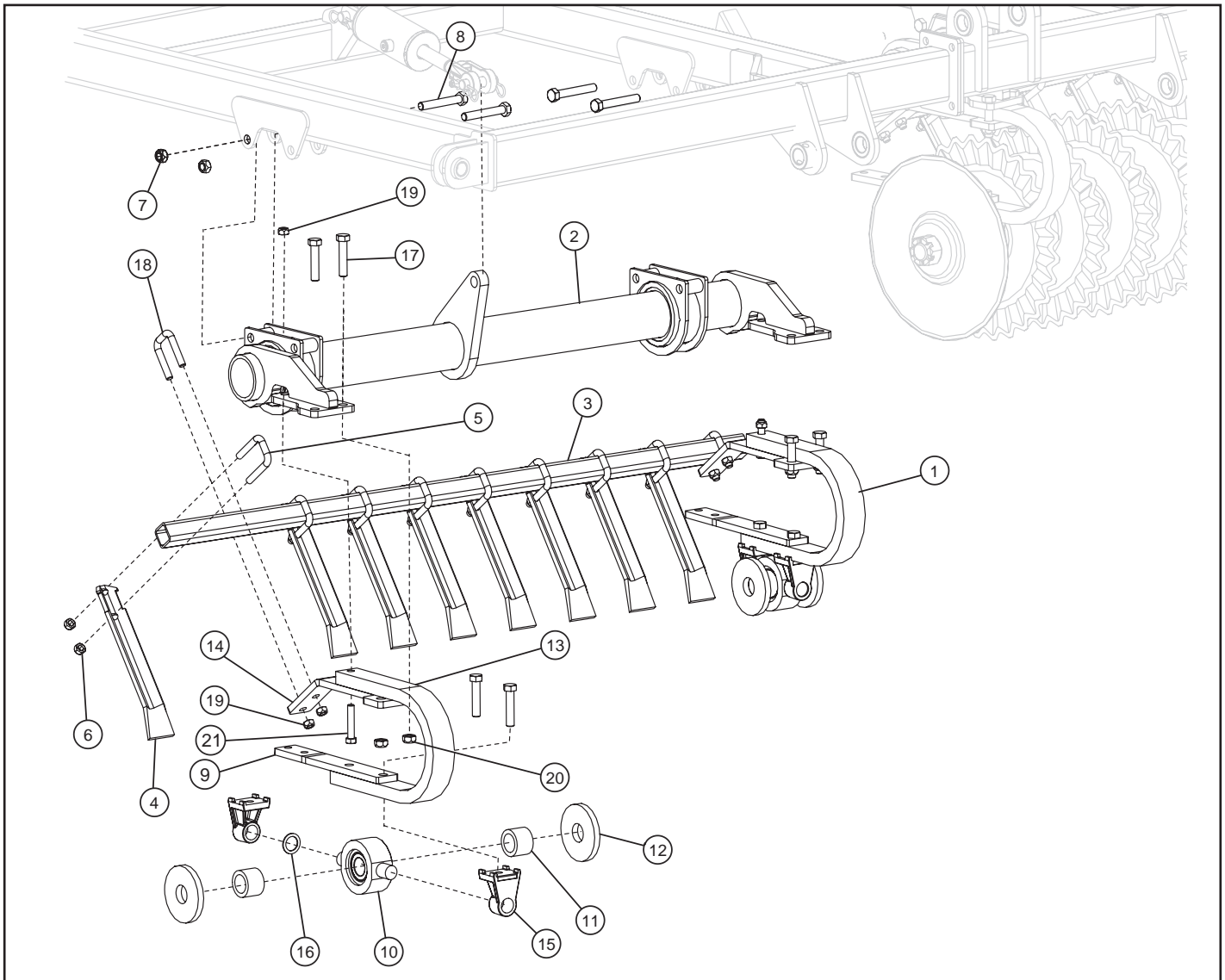

Item	Part Number	Description
1		DISK SPRING TRUNNION ASSY
2	14254	PIVOT TUBE, DISK, LT MAIN
	14282	PIVOT TUBE, DISK, RT MAIN
	14283	PIVOT TUBE, DISK, LT WING (FN-6029)
	14284	PIVOT TUBE, DISK, RT WING (FN-6029)
	14587	PIVOT TUBE, DISK, LT WING (FN-6032)
	14588	PIVOT TUBE, DISK, RT WING (FN-6032)
	14797	PIVOT TUBE, DISK, LT WING (FN-6024)
	14798	PIVOT TUBE, DISK, RT WING (FN-6024)
3	RD-4968	MOUNT TUBE, 11 SCRAPER
	RD-4897	MOUNT TUBE, 12 SCRAPER
	RD-4974	MOUNT TUBE, 8 SCRAPER
	10547	MOUNT TUBE, 7 SCRAPER
4	11366	SCRAPER
5	BU-5824	U-BOLT, HEX, 5/8-2X4
6	NLT-6311	NUT, LOCK, TOP, 5/8-11

Item	Part Number	Description
7	NLT-7510	NUT, LOCK, TOP, 3/4-10
8	BH-7545	BOLT, HEX, 3/4-10X4.5, GD5
9	12252	MOUNT, SCRAPER
10	10601	TRUNNION BEARING ASSY
11	12218	BUSHING
12	10729	PLATE, WASHER
13	11147	SPRING, C-SHANK
14	12237	PLATE, CLAMP
15	12197	BRACKET, TRUNNION
16	12253	SHIM, TRUNNION
17	BHY-7535	BOLT, HEX, 3/4-10X3.5, GD8
18	BU-5823	U-BOLT, HEX, 5/8-2X3
19	NLT-6311	NUT, LOCK, TOP, 5/8-11
20	NLT-7510	NUT, LOCK, TOP, 3/4-10
21	12780	BOLT, HEX, 5/8-11X3.25, GD8

## Disk Gang for FN-6000 Series

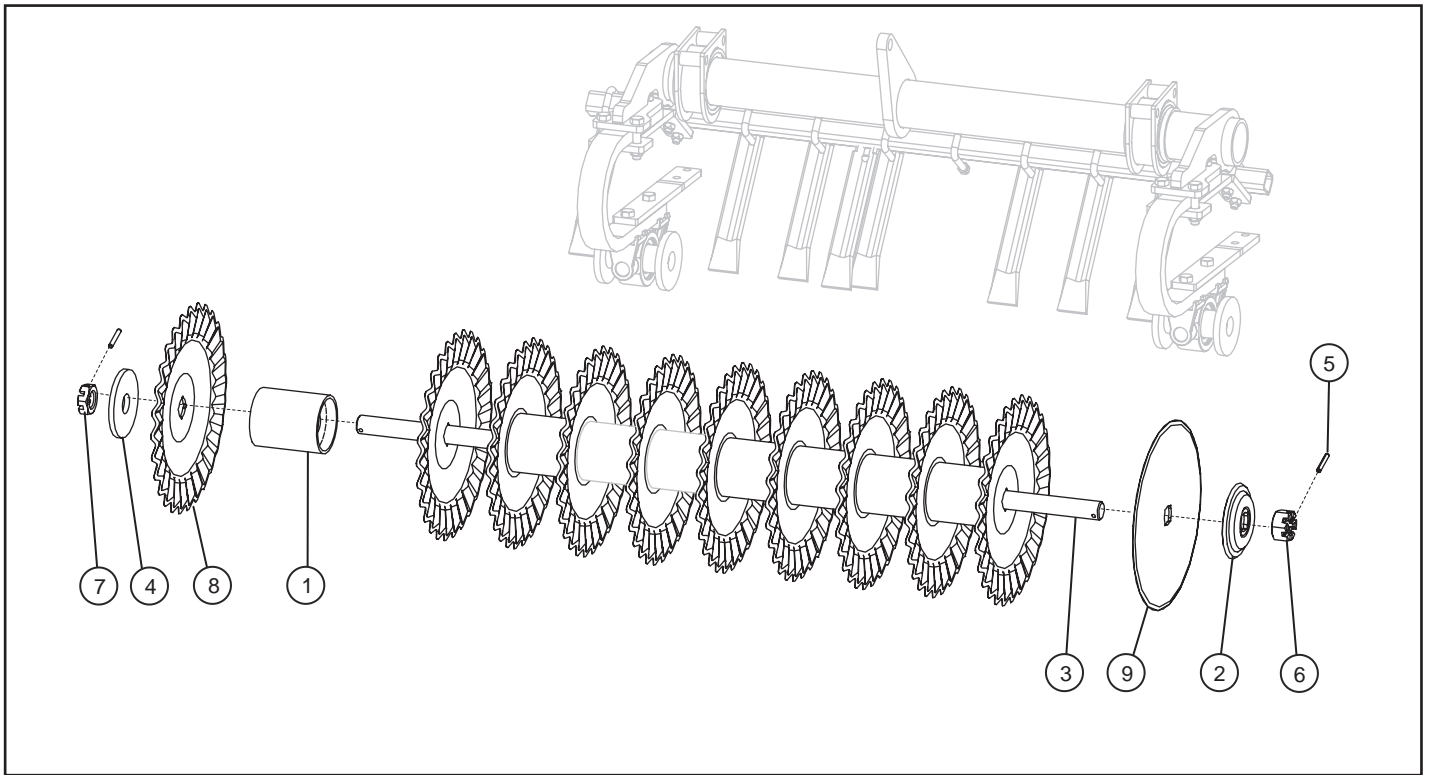

Item	Part Number	Description
1	10319	GANG SPOOL
2	10600	DISK TENSION WASHER
3	10635	DISK GANG SHAFT, RND, 74"
	12664	DISK GANG SHAFT, RND, 88"
	10746	DISK GANG SHAFT, RND, 53"
	10829	DISK GANG SHAFT, RND, 60"

Item	Part Number	Description
4	10654	RD DISK GANG END PLATE
5	10655	PIN, SPRING ROLL 3/8 X 2.50
6	10257	NUT, FINISHED SLOTTED, 1-3/4-5, PLAIN
7	10658	NUT, FINISHED SLOTTED JAM, 1-3/4-5, PLAIN
8	12793	BLADE, DISK, COBRA, 20", 6.5mm
9	RD-4925	BLADE, FLAT, 6mm, 18"

## Lift Arm for 3 Bar FA Harrow Sections

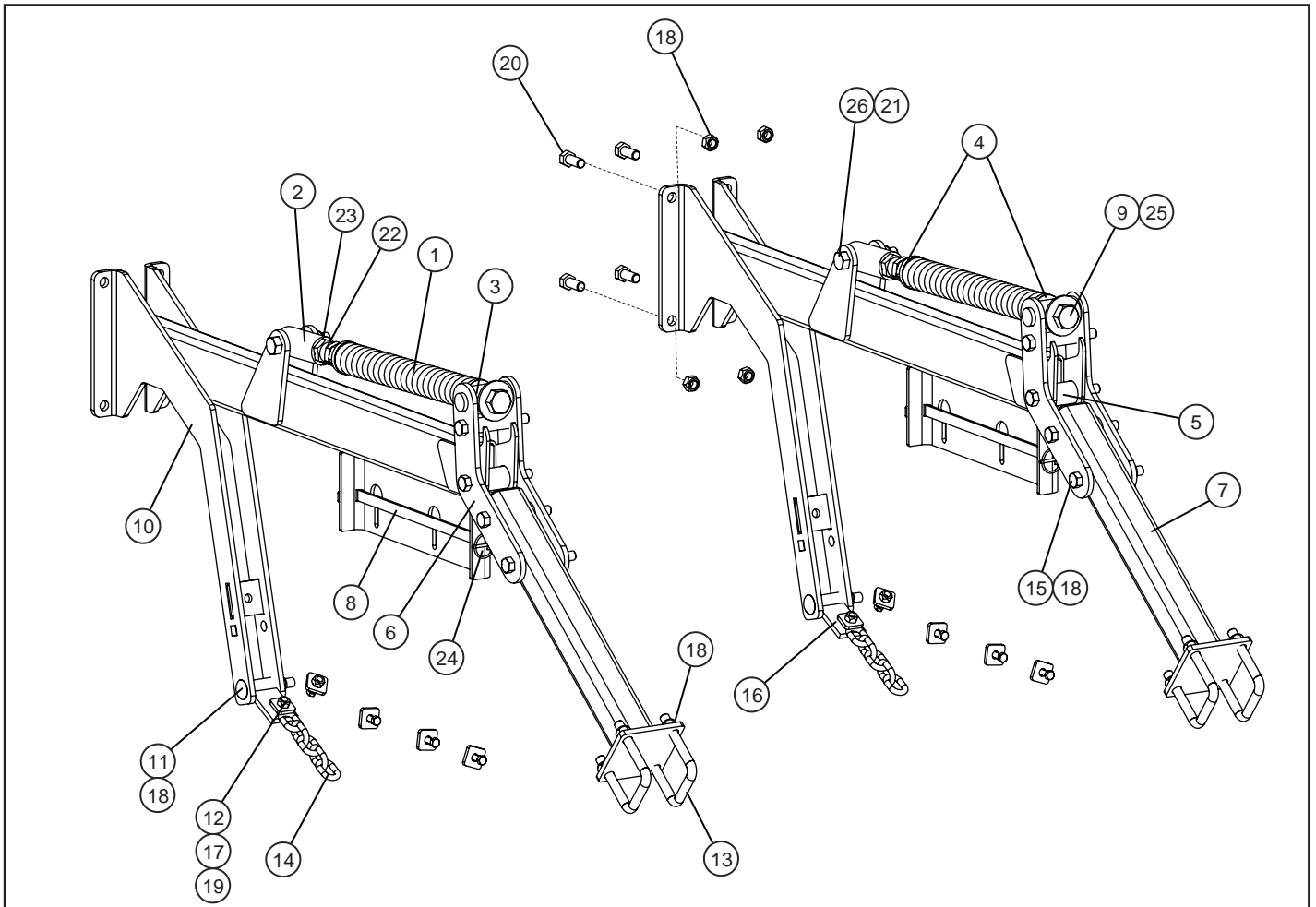

Item	Part Number	Description
1	10682	SPRING, COMPRESSION
2	10713	TUBE,ROUND,ADJUSTMENT
3	10714	BUSHING,TRUNNION
4	10715	WASHER
5	10716	TUBE, ROUND
6	10718	PLATE,PIVOT
7	10952	PIVOT ARM
8	10957	FLAT, LIFT CHAIN BRACKET LOCK
9	10959	BOLT,SPECIAL,1-8 x 23.8 GD5
10	10962	ARM, LIFT
11	BC-6340	BOLT, CARRIAGE, 5/8 X 4
12	BH-5018	BOLT, HEX, 1/2-13 X 1-3/4 GRADE 5
13	BU-5834	U-BOLT,5/8-11X3X4.5
14	CH-0805	PULL CHAIN, 5 LINK
15	BH-6350	BOLT, HEX, 5/8-11 X 5 GRADE 5
16	FA-4105	PLATE,PIVOT

Item	Part Number	Description
17	HDD-016	SQUARE WASHER, 1/2"
18	NLT-6311	NUT,LOCK,TOP,5/8-11
19	NLT-5013	NUT,LOCK,TOP,1/2-13
20	BH-6320	BOLT, HEX, 5/8-11 X 2, GRADE 5
21	NLT-7510	NUT,LOCK,TOP,3/4-10
22	NUT HEX	NUT,HEX 3/8-16
23	NHJ-1008	NUT, HEX, JAM, 1-8
24	PC-1913	PIN, CLICK 3/16 X 1 9/16
25	FW-0100	WASHER, FLAT
26	BH-7540	BOLT, HEX, 3/4-10 X 4, GRADE 5

### 3 Bar FA Harrow Section

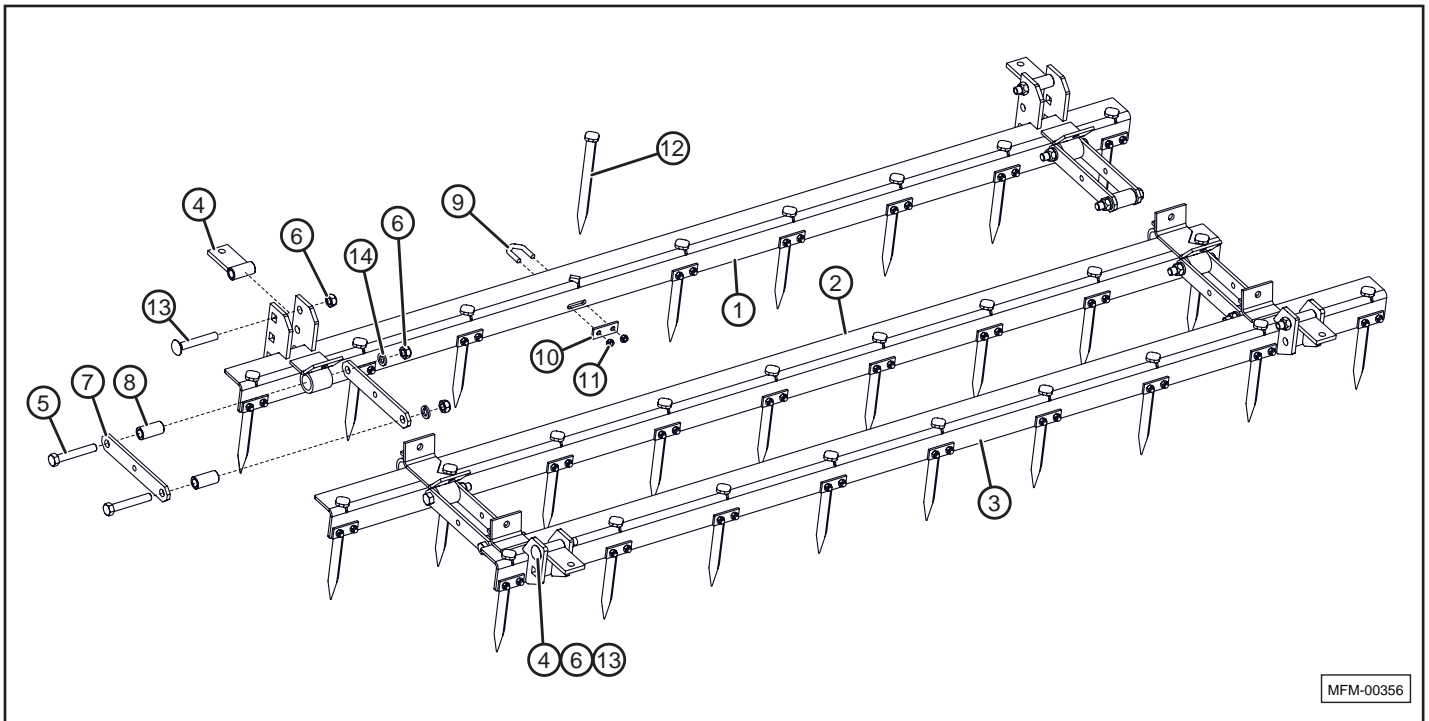

MFM-00356

Item	Part Number	Description
1	FA-551	NUMBER ONE HARROW BAR (FA-500-3)
	FA-651	NUMBER ONE HARROW BAR (FA-600-3)
	FA-751	NUMBER ONE HARROW BAR (FA-700-3)
	FA-851	NUMBER ONE HARROW BAR (FA-800-3)
	FA-951	NUMBER ONE HARROW BAR (FA-900-3)
2	FA-556	NUMBER TWO HARROW BAR (FA-500-3)
	FA-656	NUMBER TWO HARROW BAR (FA-600-3)
	FA-756	NUMBER TWO HARROW BAR (FA-700-3)
	FA-856	NUMBER TWO HARROW BAR (FA-800-3)
	FA-956	NUMBER TWO HARROW BAR (FA-900-3)
3	FA-557	NUMBER THREE HARROW BAR (FA-500-3)
	FA-657	NUMBER THREE HARROW BAR (FA-600-3)
	FA-757	NUMBER THREE HARROW BAR (FA-700-3)
	FA-857	NUMBER THREE HARROW BAR (FA-800-3)
	FA-957	NUMBER THREE HARROW BAR (FA-900-3)
4	FA-4105	PLATE, PIVOT
5	BH-6340	BOLT, HEX, 5/8-11 X 4 GRADE 5
6	NLT-6311	NUT, TOP LOCK, 5/8-11

Item	Part Number	Description
7	CT-105	CONNECTOR, FLAT
8	CT-102	BUSHING, INNER
9	BV-3812	3/8" V BOLT
10	FA-4103	PLATE, 3/8" V-BOLT
11	NLT-3816	NUT, TOP LOCK, 3/8-16
12	FA-4110	TOOTH, 3/4" X 10"
13	BC-6340	BOLT, CARRIAGE, 5/8-11 X 4 GRADE 5
14	LW-0063	WASHER, LOCK, 5/8

## Lift Arm for 5 Bar FA Harrow Section

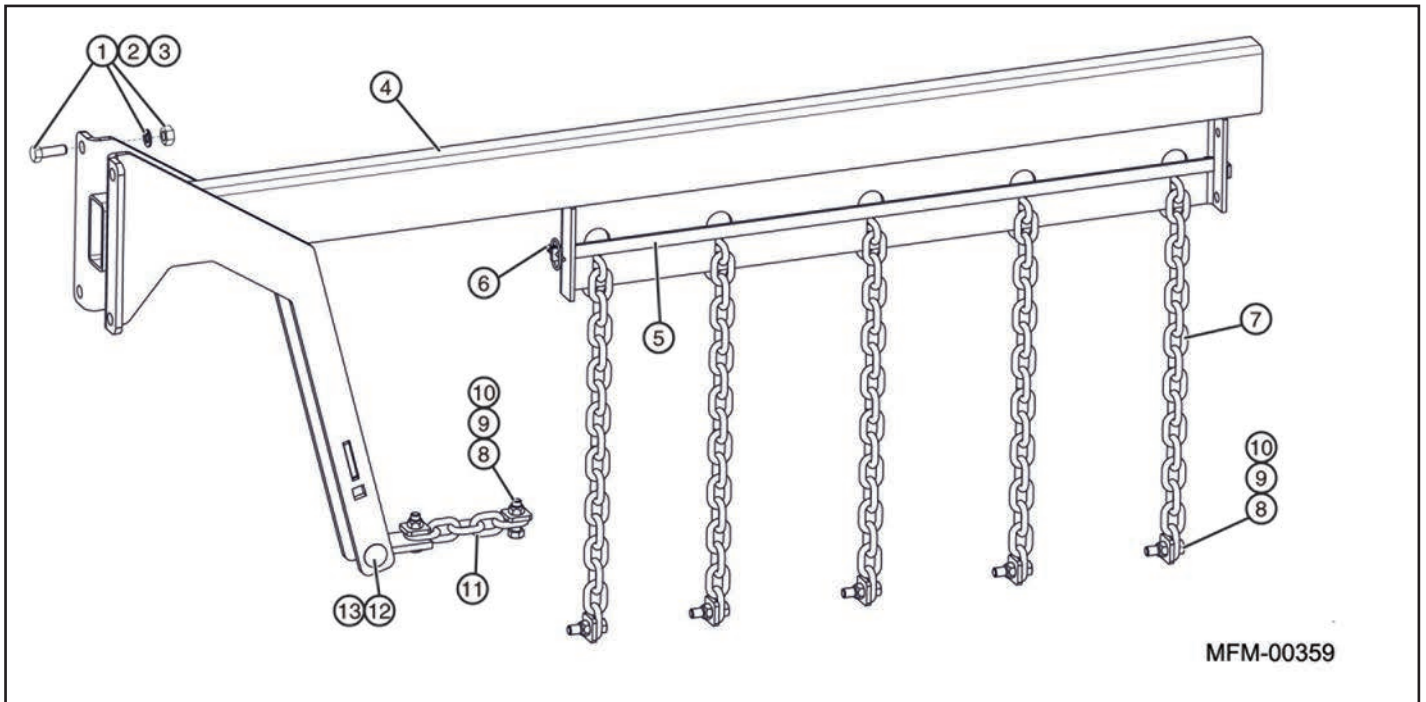

Item	Part Number	Description
1	BH-6320	BOLT, HEX, 5/8-11 X 2, GRADE 5
2	LW-0063	WASHER, LOCK, 5/8
3	NH-6311	NUT, HEX, 5/8-11
4	12706	ARM, LIFT
5	RD-4629	BAR, LOCK
6	PC-1913	CLICK PIN, 3/16 X 1-9/16
7	CH-0816	LIFT CHAIN, 16 LINK
8	BH-5018	BOLT, HEX, 1/2-13 X 1-3/4 GRADE 5

Item	Part Number	Description
9	HDD-016	WASHER, SQUARE, 1/2"
10	NLT-5013	NUT, TOP LOCK, 1/2-13
11	CH-0805	PULL CHAIN, 5 LINK
12	NLT-6311	NUT, TOP LOCK, 5/8-11
13	BC-6340	BOLT, CARRIAGE, 5/8 X 4

## 5 Bar FA Harrow Section

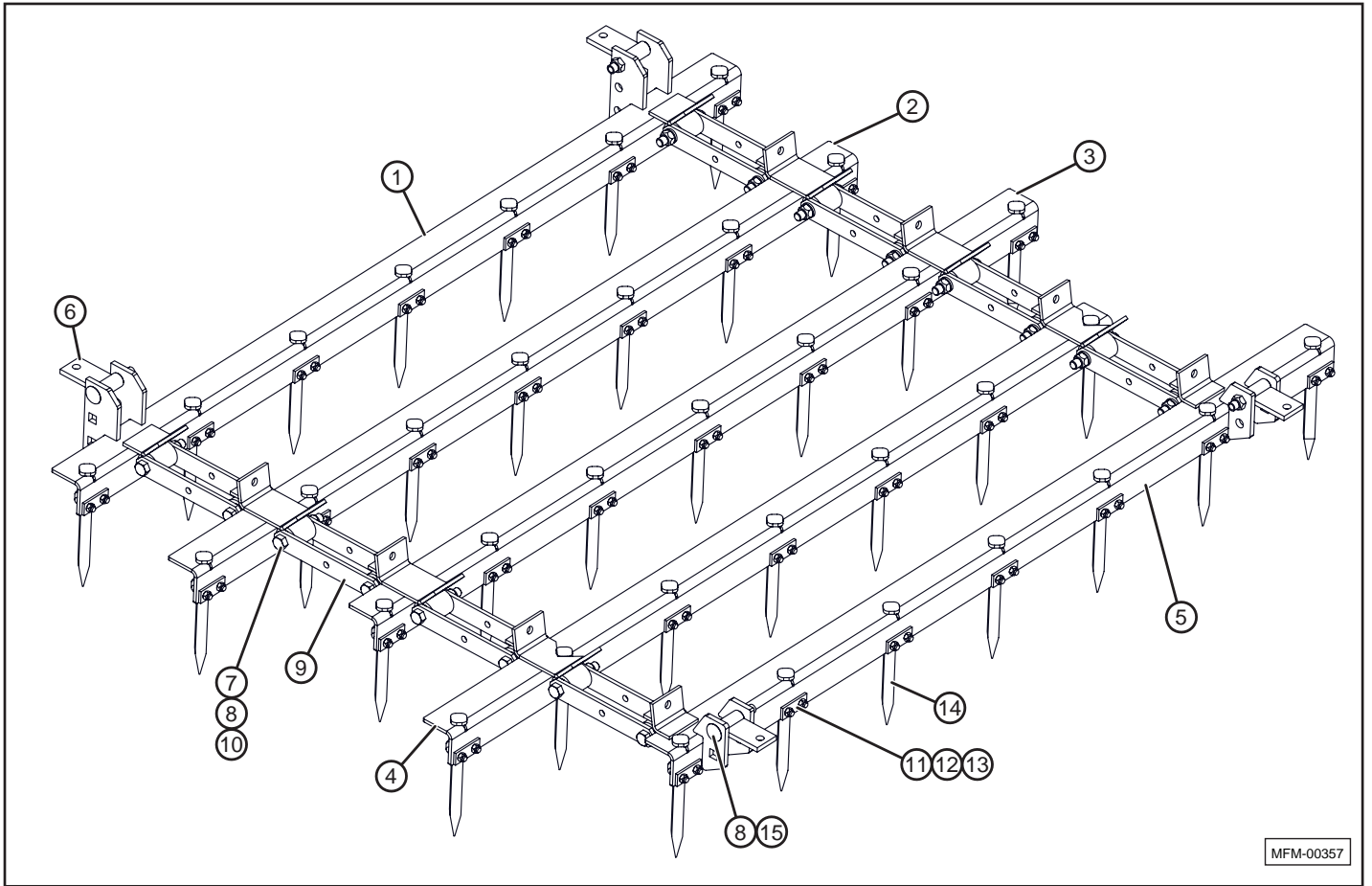

Item	Part Number	Description
1	FA-551 FA-651 FA-751 FA-851	NUMBER ONE HARROW BAR (FA-500-5) NUMBER ONE HARROW BAR (FA-600-5) NUMBER ONE HARROW BAR (FA-700-5) NUMBER ONE HARROW BAR (FA-800-5)
2	FA-552 FA-652 FA-752 FA-852	NUMBER TWO HARROW BAR (FA-500-5) NUMBER TWO HARROW BAR (FA-600-5) NUMBER TWO HARROW BAR (FA-700-5) NUMBER TWO HARROW BAR (FA-800-5)
3	FA-553 FA-653 FA-753 FA-853	NUMBER THREE HARROW BAR (FA-500-5) NUMBER THREE HARROW BAR (FA-600-5) NUMBER THREE HARROW BAR (FA-700-5) NUMBER THREE HARROW BAR (FA-800-5)
4	FA-556 FA-656 FA-756 FA-856	NUMBER FOUR HARROW BAR (FA-500-5) NUMBER FOUR HARROW BAR (FA-600-5) NUMBER FOUR HARROW BAR (FA-700-5) NUMBER FOUR HARROW BAR (FA-800-5)
5	FA-557 FA-657 FA-757 FA-857	NUMBER FIVE HARROW BAR (FA-500-5) NUMBER FIVE HARROW BAR (FA-600-5) NUMBER FIVE HARROW BAR (FA-700-5) NUMBER FIVE HARROW BAR (FA-800-5)
6	FA-4105	PLATE, PIVOT

Item	Part Number	Description
7	BH-6340	BOLT, HEX, 5/8-11 X 4 GRADE 5
8	NLT-6311	NUT, TOP LOCK, 5/8-11
9	CT-105	CONNECTOR, FLAT
10	CT-102	BUSHING, INNER
11	BV-3812	3/8" V BOLT
12	FA-4103	PLATE, 3/8" V-BOLT
13	NLT-3816	NUT, TOP LOCK, 3/8-16
14	FA-4110	TOOTH, 3/4" X 10"
15	BC-6340	BOLT, CARRIAGE, 5/8-11 X 4 GRADE 5

## Spur-Till Option With Mount for FN-6000 Series

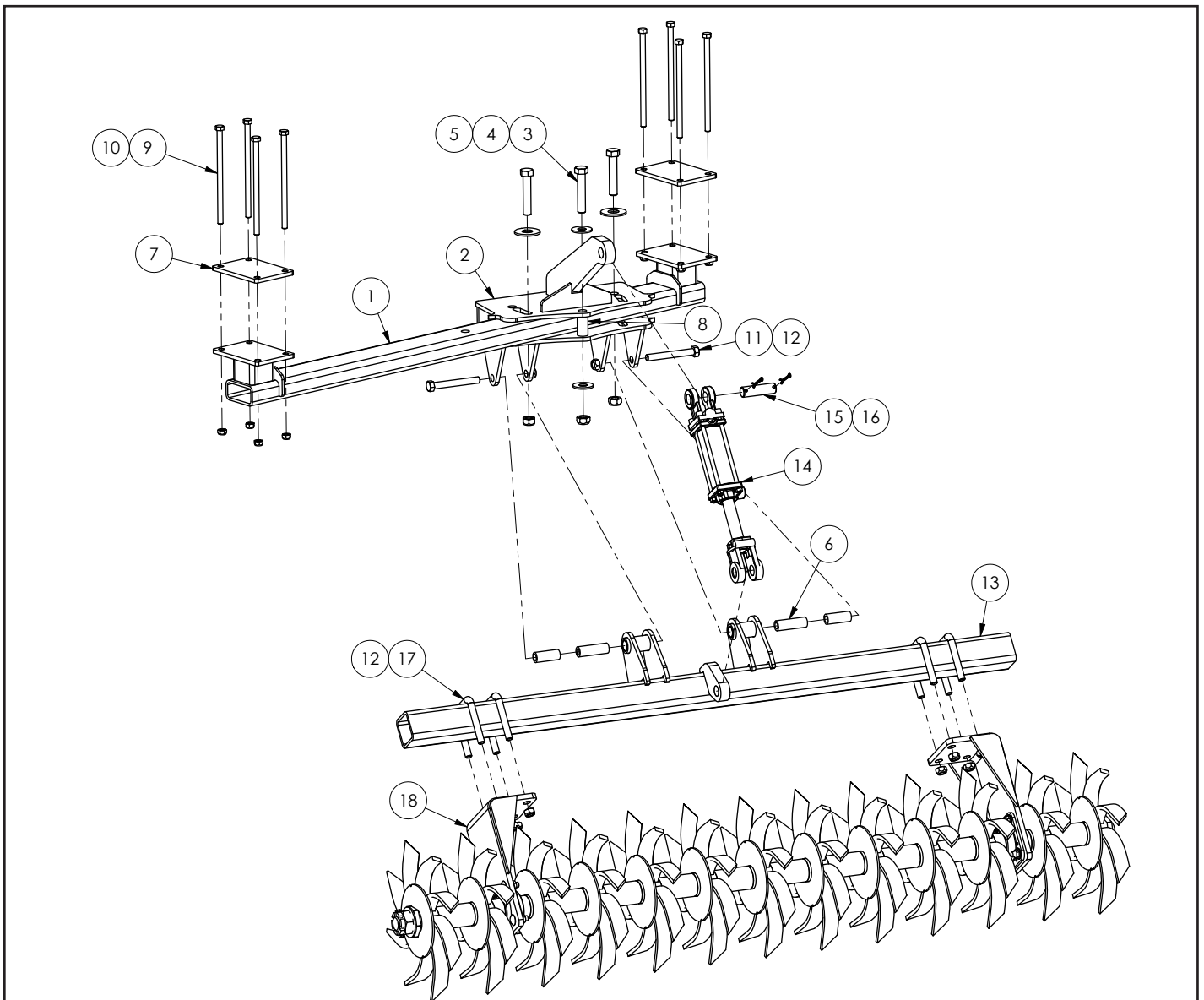

Item	Part Number	Description
1	14623	MOUNT TUBE, MAIN
	14627	MOUNT TUBE, WING
2	14518	PIVOT MOUNT ASSY
3	BH-7540	BOLT, HEX, 3/4-10X4, GD5
4	FW-0075	WASHER, FLAT, .75
5	NLT-7510	NUT, LOCK, TOP, 3/4-10
6	10716	TUBE, ROUND
7	14301	PLATE, CLAMP
8	15079	BUSHING
9	BH-5065	BOLT, HEX, 1/2-13X6.5, GD5
10	NLT-5013	NUT, LOCK, TOP, 1/2-13
11	BH-5035	BOLT, HEX, 1/2-13X3.5, GD5

Item	Part Number	Description
12	NLT-6311	NUT, LOCK, TOP, 5/8-11
13	14106	SPUR-TILL MOUNT, 74"
	14160	SPUR-TILL MOUNT, 44"
	14138	SPUR-TILL MOUNT, 65"
	14202	SPUR-TILL MOUNT, 82"
14	HYC-32004	HYD CYLINDER, 2X4
15	HYO-2103	PIN, CYLINDER CLEVIS, 1X3-1/2
16	CP-3620	PIN, COTTER, 3/16X2
17	BU-5834	U-BOLT, 5/8-11X3X45
18	13785	LEVELER MOUNT

## Spur-Till Gang for FN-6000 Series

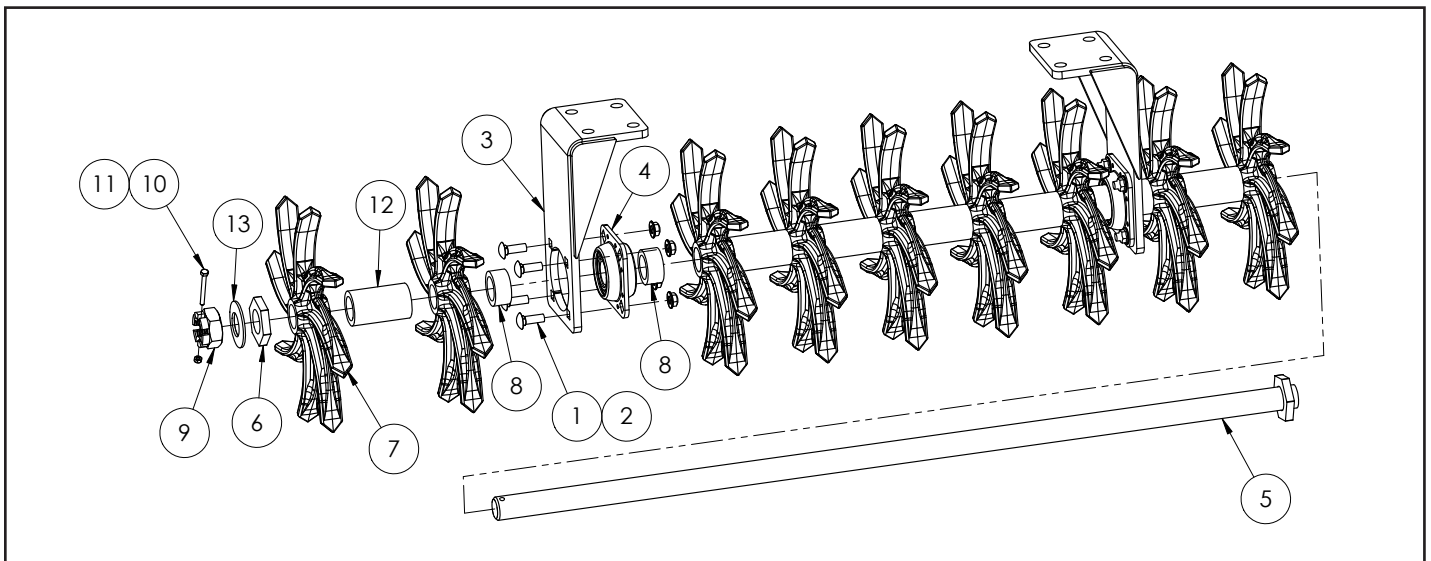

Item	Part Number	Description	Item	Part Number	Description
1	BC-5015	BOLT, CARRIAGE,1/2-13X1.5, GD5	7	13916	SPURTILL WHEEL, LH
2	14599	NUT, UNITORQUE LOCK, FLANGED,1/2-13 GRG ZP	8	14137	TUBE
3	13785	LEVELER MOUNT	9	14400	1-1/2"-6 SLOTTED NUT
4	14204	BEARING, FLANGED,1.50 RND	10	BH-2525	BOLT, HEX,1/4-20X2.5, GD5
5	14420	WELDED SHAFT-71.22	11	NLT-2520	NUT, TOP LOCK 1/4-20
5	14421	WELDED SHAFT-89.18	12	13968	TUBE
5	14426	WELDED SHAFT-65.22	13	14694	BELLEVILLE DISC SPRING
5	14431	WELDED SHAFT-77.19			
5	14432	WELDED SHAFT53.22			
5	14443	WELDED SHAFT-95.19			
6	13969	PLATE, WASHER			

## Rolling Basket for FN-6000 Series

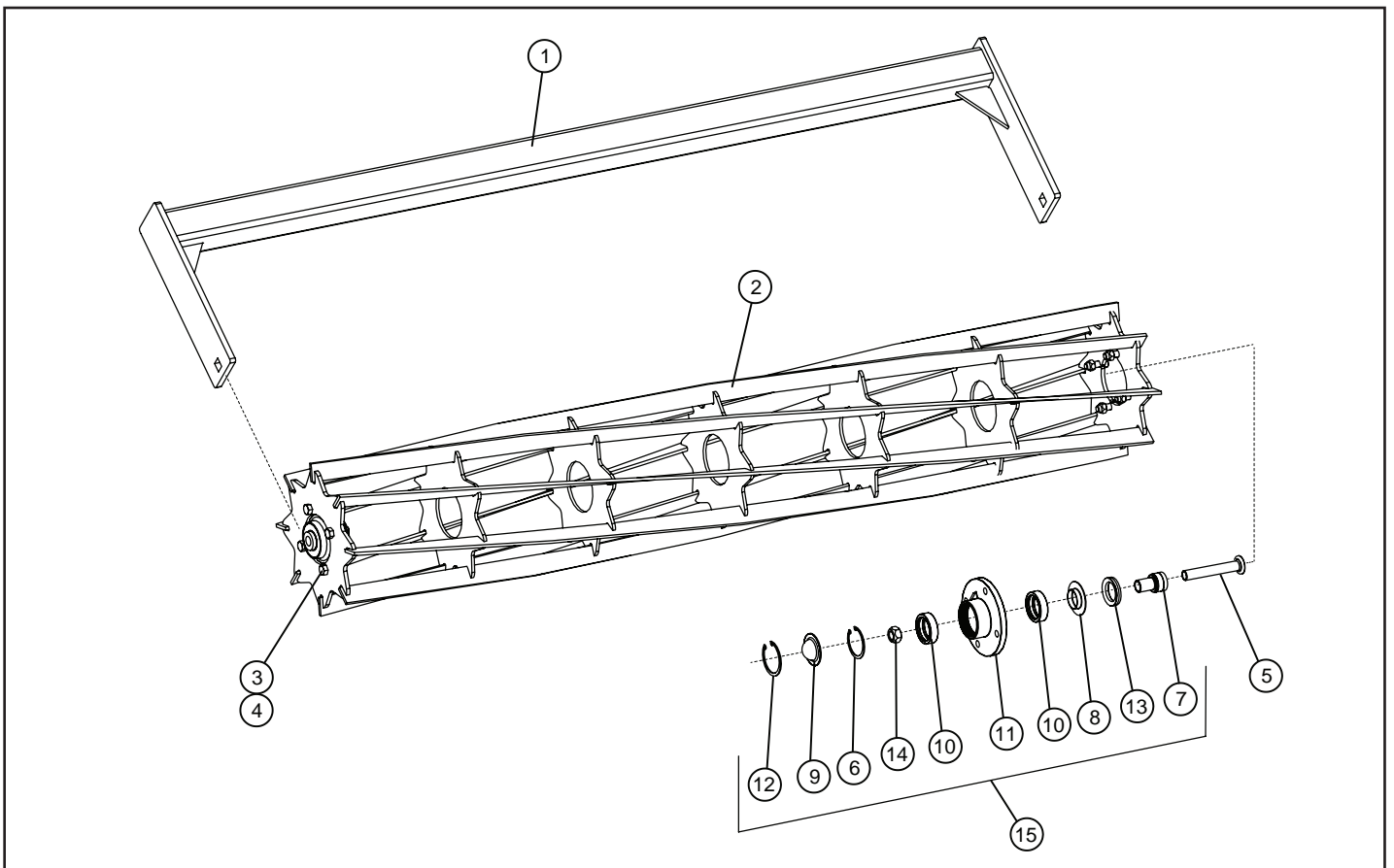

Item	Part Number	Description
1	RD-5078	MOUNT TUBE, ROLLING BASKET, 74"
	RD-5081	MOUNT TUBE, ROLLING BASKET, 96"
	14719	MOUNT TUBE, ROLLING BASKET, 117"
2	SRB-1574	ROLLING BASKET, 74"
	SRB-1596	ROLLING BASKET, 96"
	14718	ROLLING BASKET, 117"
3	BH-5015	BOLT, HEX, 1/2-13X1.5, GD5
4	NLT-5013	NUT, LOCK, TOP, 1/2-13
5	BC-7535	BOLT, CARRIAGE, 3/4-10X3.5, GD8
6	13076	SNAP RING
7	13077	BEARING SLEEVE W/GUARD

Item	Part Number	Description
8	13079	SEAL COUNTERFACE
9	13078	DUST CAP
10	13074	BEARING, SEALED, 1" ID
11	13080	HUB
12	13081	RETAINING RING
13	13075	V-SEAL, 1.59" ID
14	NLT-7510	NUT, LOCK, TOP, 3/4-10
15	12713	ASM, HUB

## Wing Locks for FN-6000 Series

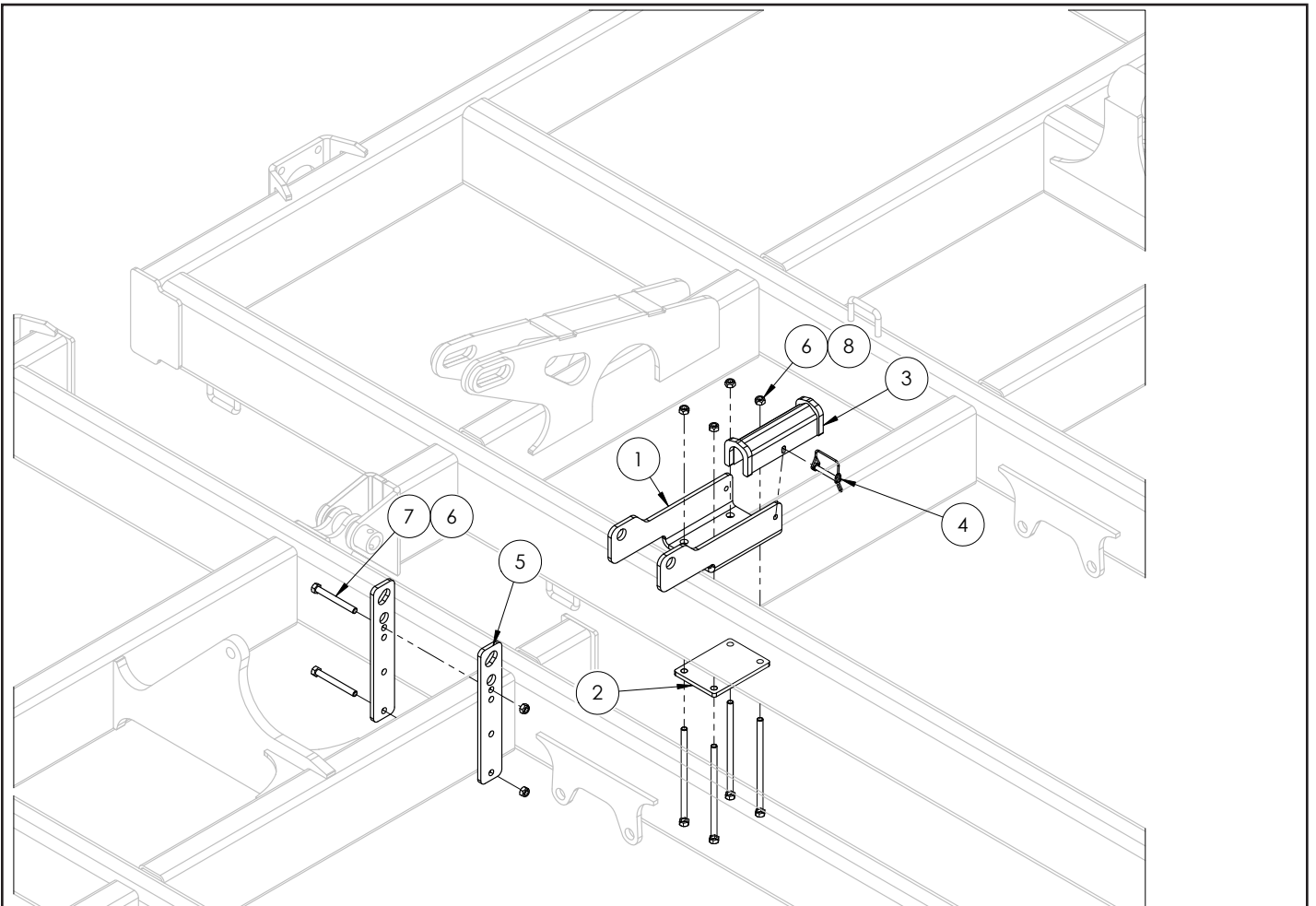

Item	Part Number	Description
1	14355	BRACKET, WING LOCK
2	14301	PLATE, CLAMP
3	HYS-1208	CYLINDER LOCK, 1-1/2X8
4	LP-3825	PIN, LYNCH, TOP, 3/8X2-1/2
5	14356	PLATE, WING LOCK
6	NLT-5013	NUT, LOCK, TOP, 1/2-13
7	BH-5045	BOLT, HEX, 1/2-13X4.5, GD5
8	BH-5095	BOLT, HEX, 1/2-13X9.5, GD5

## Jack for FN-6000 Series

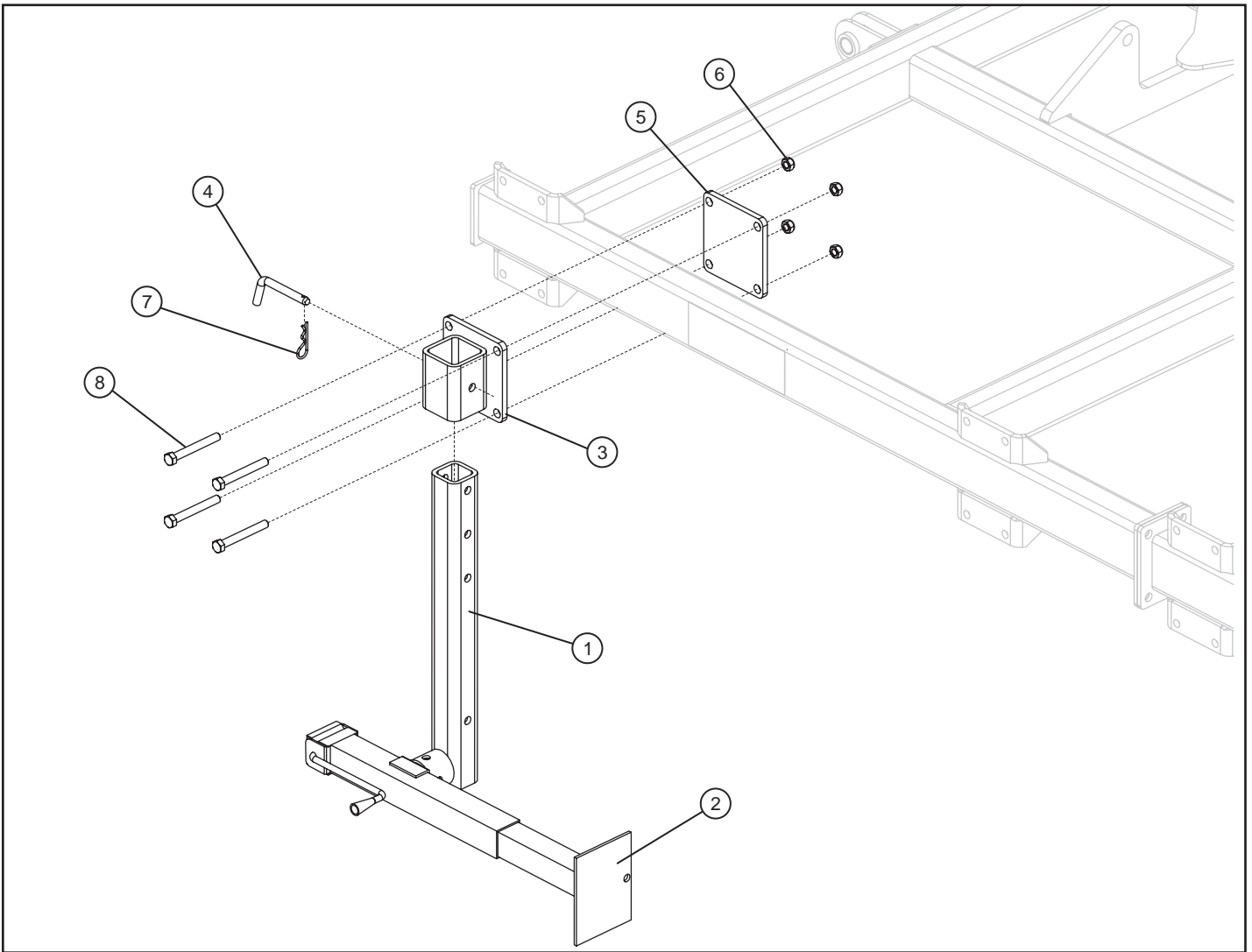

Item	Part Number	Description
1	14238	ASSY, JACK TUBE
2	QT-1234	JACK, SIDEWIND, 15", 8000#
3	14822	JACK MOUNT
4	11033	PIN, HITCH, 5/8X4
5	14823	MOUNT PLATE
6	NLT-6311	NUT, LOCK, TOP, 5/8-11
7	PB-0009	PIN, BRIDGE, #9
8	BH-6350	BOLT, HEX, 5/8-11X5, GD5

## Lighting Diagram for FN-6000 Series

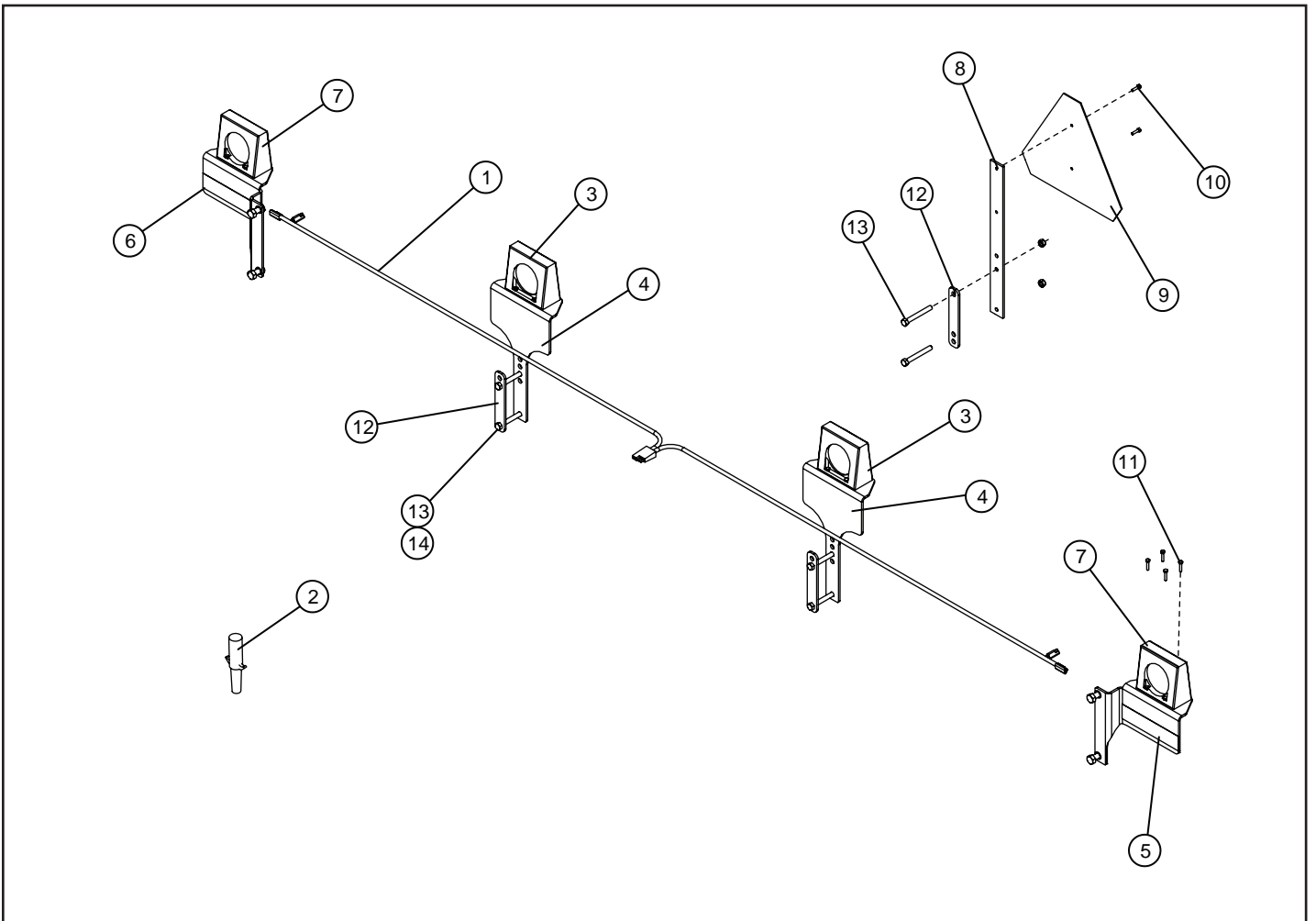

Item	Part Number	Description
1	16214	LIGHT HARNESS,4-PIN/3-2-PIN,13'
2	16210	LIGHT ENHANCER MODULE
3	16212	LIGHT,RED-BLACK,LED
4	RD-5056	BRACKET, LIGHT, SINGLE
5	12175	BRACKET, LIGHT, SINGLE, LT
6	12176	BRACKET, LIGHT, SINGLE, RT
7	16211	LIGHT,AMBER-AMBER,LED

Item	Part Number	Description
8	LB-1203	BRACKET, SMV MOUNT
9	MM-1300	SMV SIGN
10	BH-2510	BOLT, HEX, 1/4-20X1, GD5
11	BH-2515	BOLT, HEX, 1/4-20X1.5, GD5
12	14526	PLATE, CLAMP, 5"-6"
13	BH-5040	BOLT, HEX, 1/2-13X4, GD5
14	NLT-5013	NUT, LOCK, TOP, 1/2-13

## Hub Components for HD-1371

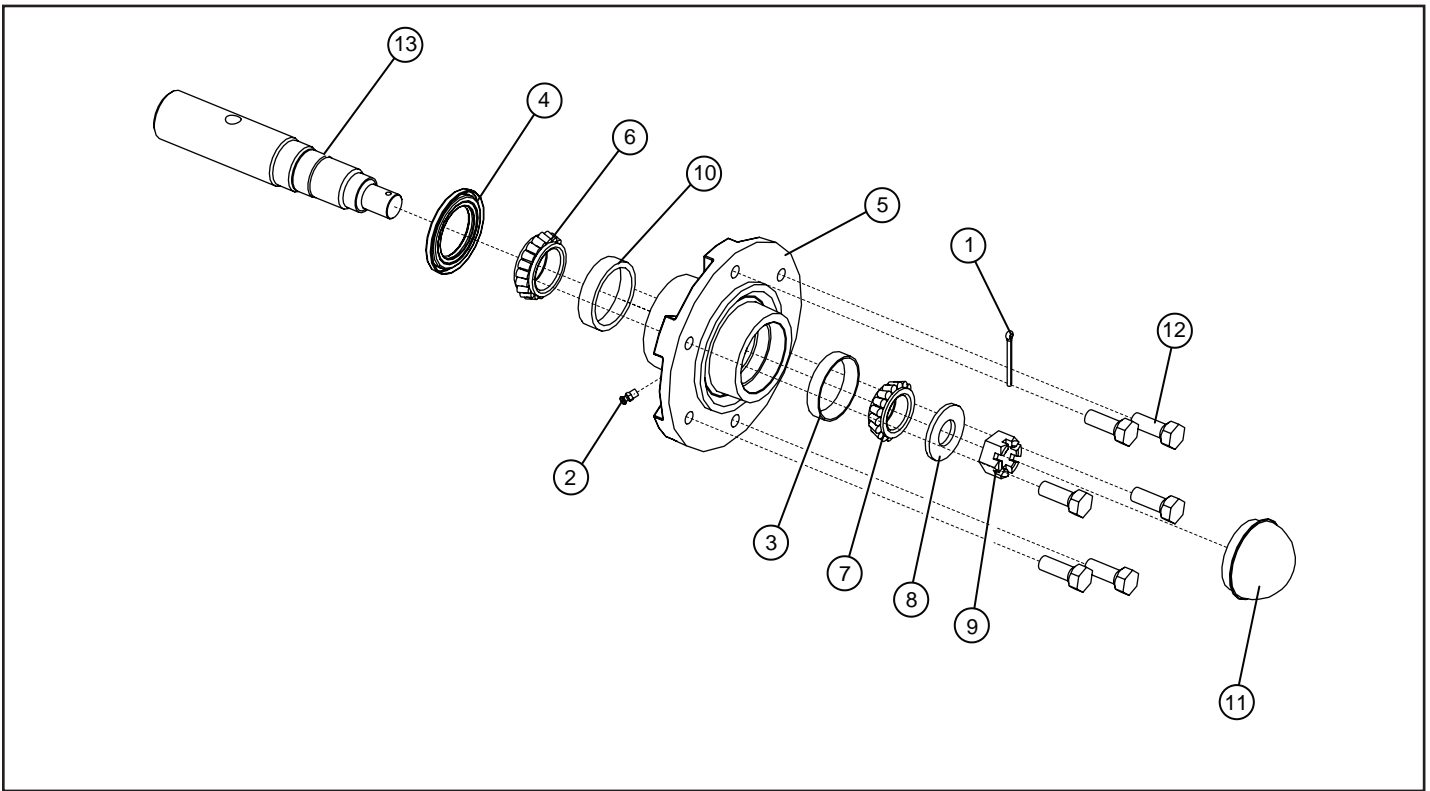

Item	Part Number	Description
<b>6-HOLE HUB, 3560 LB</b>		
1	CP-1517	PIN, COTTER, .150 X 1-3/4
2	GZ-0601	GREASE FITTING
3	HD-1171	BEARING RACE, 4 INNER/6&8 OUTER
4	HD-1360	GREASE SEAL, 6-HOLE HUB
5	HD-1361	HUB, WITH RACES
6	HD-1362	INNER BEARING, 6-HOLE HUB
7	HD-1363	OUTER BEARING, 6/8 HOLE HUB

Item	Part Number	Description
8	HD-1364	SPINDLE FLAT WASHER, 6-HOLE HUB
9	HD-1365	SPINDLE HEX NUT, 6-HOLE HUB
10	HD-1366	6-HOLE HUB INNER RACE
11	HD-1367	DUST CAP, 6-HOLE HUB
12	WB-5010	WHEEL BOLT, 1/8-1.25
13	WDL-2505	SPINDLE
—	HD-1371	6-HOLE HUB ASSEMBLY (Includes items 2, 3, 4, 5, 7, 8, 10, 11, 12)

## Hub Components for RT-3181

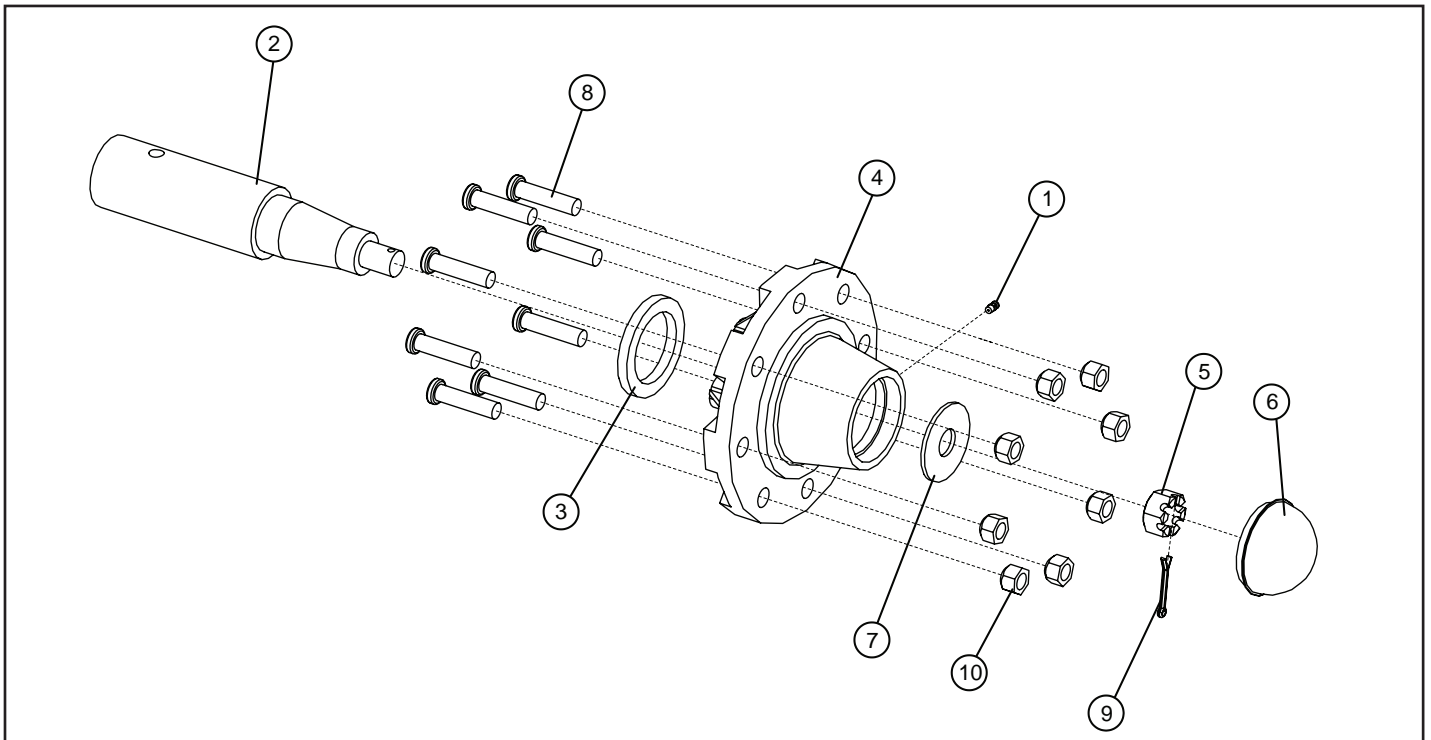

Item	Part Number	Description
<b>8-HOLE HUB, 4500 LB</b>		
1	GZ-0601	GREASE FITTING
2	RT-3180	SPINDLE, 2-3/4X12-1/2, W HOLE
3	RT-3182	GREASE SEAL, 8-HOLE HD HUB
4	RT-3184	HUB, WITH RACES, 8-BOLT HD HUB
5	RT-3187	SPINDLE, HEX NUT
6	RT-3188	DUST CAP, 6-HOLE HUB
7	RT-3190	SPINDLE FLAT WASHER

Item	Part Number	Description
8	RT-3193	WHEEL STUD, 5/8-18X2-1/2
9	SAE J487A	PIN, COTTER, .207 X 2
10	WN-0063	WHEEL NUT, 5/8
—	RT-3181	8-BOLT HUB ASSEMBLY, 6000 LB (Includes items 1, 3, 4,8,10)

## Wheel Lift Hydraulic Layout for FN-6000 Series

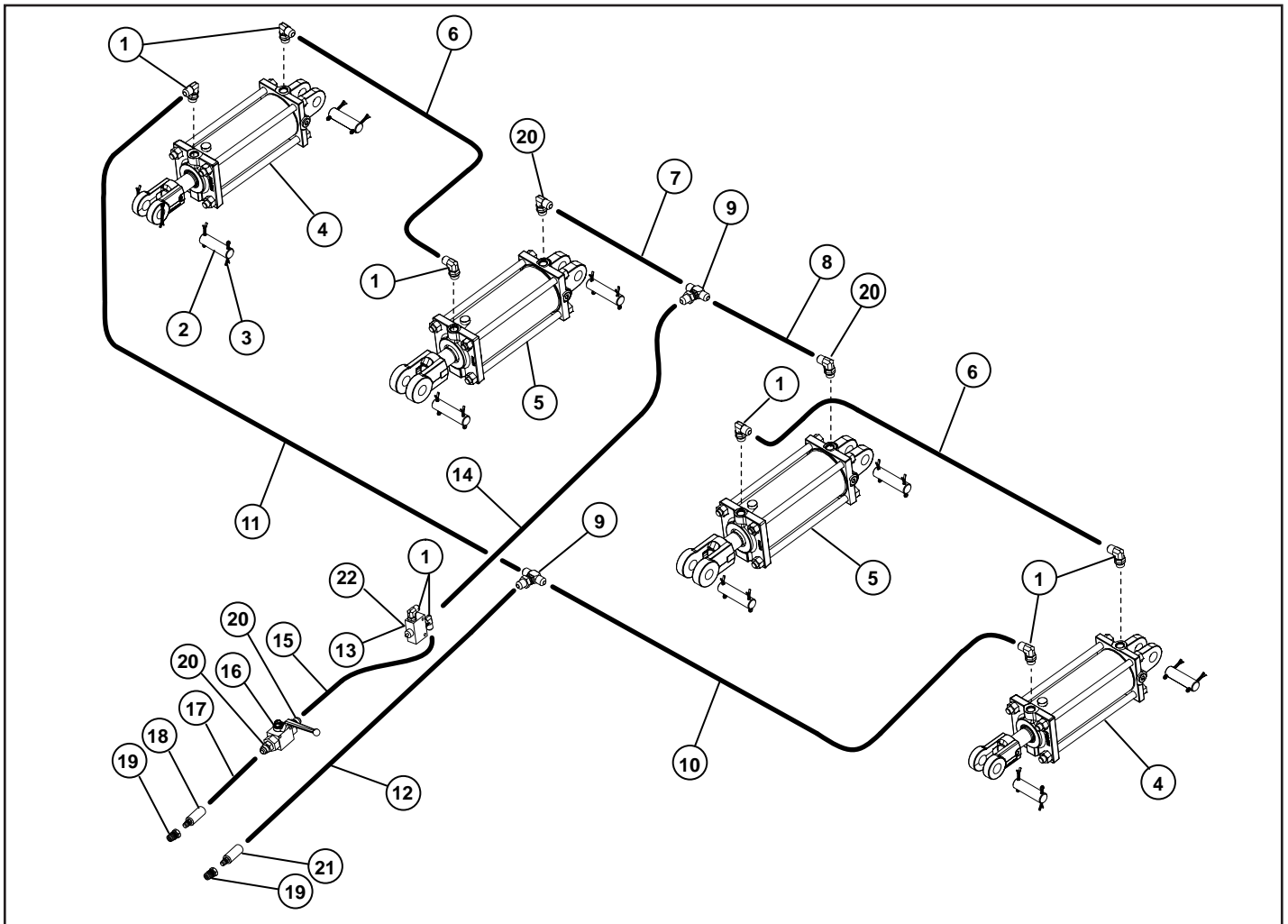

Item	Part Number	Description
1	HYF-2220	HYDRAULIC ELBOW, 3/4M- 3/4 Morb
2	HYO-2103	PIN, CYLINDER CLEVIS, 1 X 3-1/2
3	CP-3620	COTTER PIN
4	10323	HYD CYLINDER,4X10 REPHASING,WELDED
5	10322	HYD CYLINDER,4.25X10 REPHASING,WELDED
6	HYH-2112	HYD HOSE,1/2(3/4F),112
	16645	HYD HOSE,1/2(3/4F),148
7	HYH-2024	HYD HOSE,1/2(3/4F),24
8	HYH-2060	HYD HOSE,1/2(3/4F),60
9	HYF-1222	HYDRAULIC TEE, 3/4M-3/4M-3/4M
10	16645	HYD HOSE,1/2(3/4F),148
	14846	HYD HOSE,1/2(3/4F),190
11	11328	HYD HOSE,1/2(3/4F),125

Item	Part Number	Description
	HYH-2160	HYD HOSE,1/2(3/4F),160
12	14838	HYDRAULIC HOSE, 1/2 X 320
13	HYO-3021	HYDRAULIC STOP VALVE, RESTRICTED
14	14896	HYDRAULIC HOSE, 1/2 X 190
15	13684	HYDRAULIC HOSE, 1/2 X 120
16	QT-1172	HYDRAULIC VALVE, 3/4 BALL
17	15628	HYD HOSE,1/2(3/4F-3/4ORB),96
18	10536	HYDRA GRIP,SUPPLY,YELLOW
19	15641	HYD DISCONNECT,MALE,3/4ORB
20	HYH-3220	HYDRAULIC ADAPTER, 3/4M - 3/4Morb
21	10537	HYDRA GRIP,RETURN,YELLOW
22	HYF-0150	HYD PLUG,3/4ORB

## Wing Fold Hydraulic Layout for FN-6000 Series

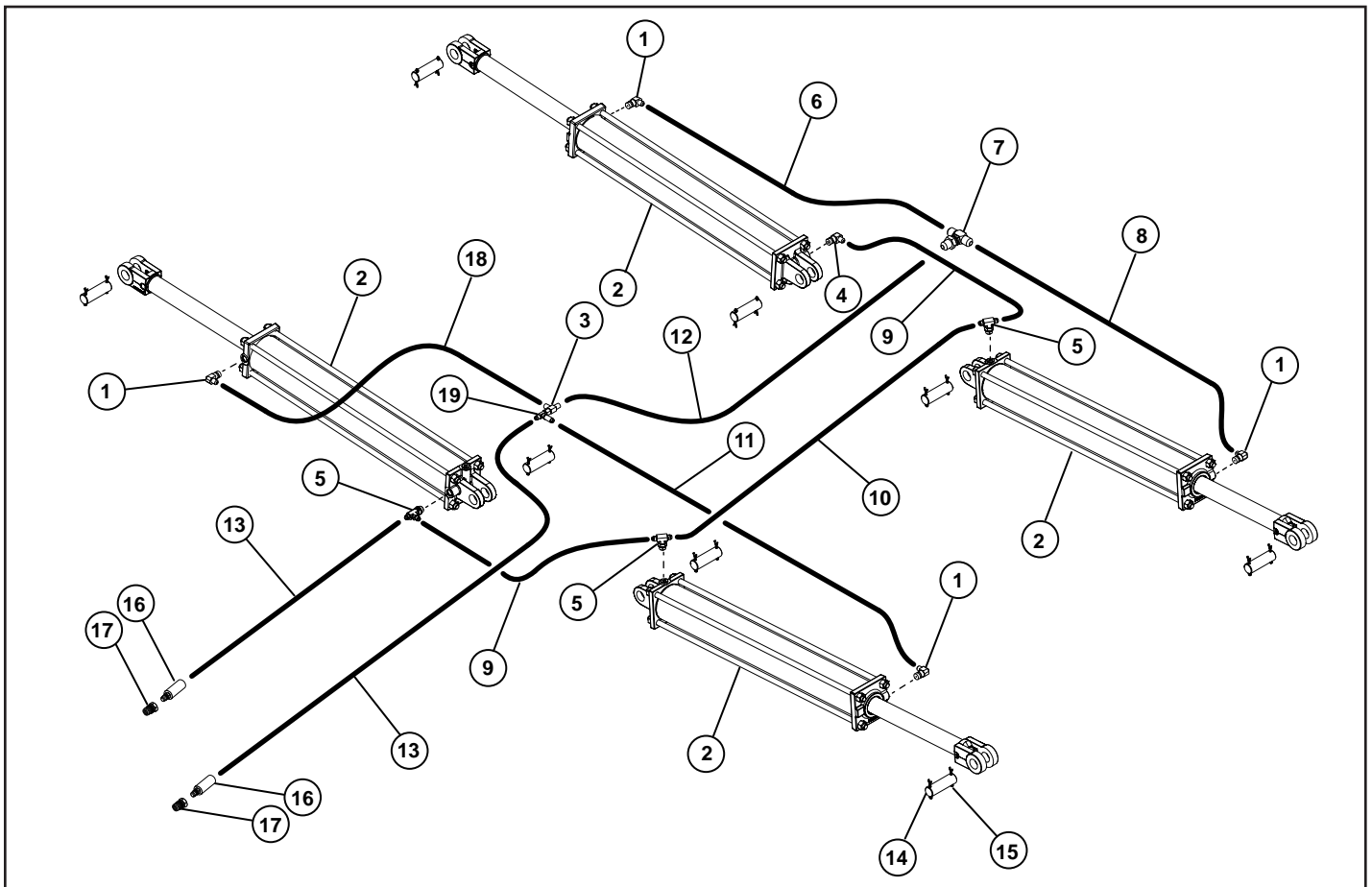

Item	Part Number	Description
1	HYF-2821	HYDRAULIC ELBOW, 9/16M-3/4Morb, RST
2	HYC-4030	HYDRAULIC CYLINDER, 4 X 30
3	HYH-1188	HYD TEE, 9/16F-9/16M-9/16M
4	HYF-2820	HYDRAULIC ELBOW, 9/16M-3/4Morb
5	HYF-1809	HYDRAULIC TEE, 9/16M-3/4Morb-9/16M
6	14840	HYDRAULIC HOSE, 3/8 (9/16F) X 46
7	16630	HYD HOSE, 3/8(9/16F-3/4Morb),276
8	HYF-1089	HYD TEE,9/16M-9/16M-3/4Morb
9	10854	HYDRAULIC HOSE, 3/8 (9/16F) X 40
10	HYH-8104	HYDRAULIC HOSE, 3/8 (9/16F) X 104

Item	Part Number	Description
11	HYH-8070	HYDRAULIC HOSE, 3/8 (9/16F) X 70
12	HYH-8084	HYDRAULIC HOSE, 3/8 (9/16F) X 84
13	15638	HYD HOSE, 3/8(9/16F-3/4Morb),265
14	HYO-2123	PIN, CYLINDER CLEVIS
15	CP-3620	COTTER PIN
16	15032	HYDRA GRIP,SUPPLY,RED
17	15641	HYD DISCONNECT,MALE,3/4ORB
18	HYH-8036	HYDRAULIC HOSE, 3/8 (9/16F) X 36
19	HYF-1888	HYD TEE, 9/16M-9/16M-9/16M
20	15033	HYDRA GRIP,RETURN,RED

## Disk Gang Hydraulic Layout for FN-6000 Series

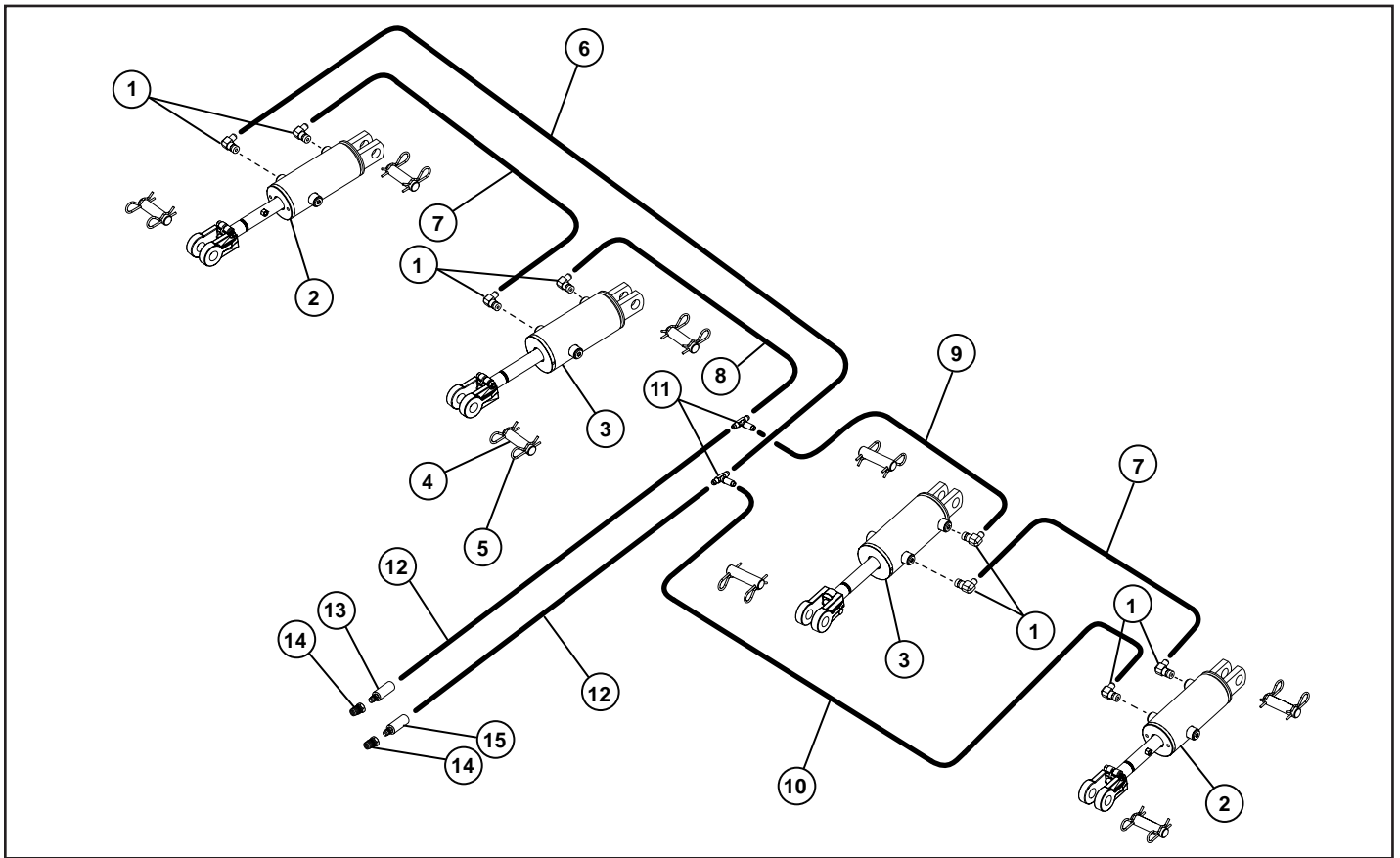

Item	Part Number	Description
1	HYF-2820	HYDRAULIC ELBOW, 9/16M-3/4Morb
2	10326	HYDRAULIC CYLINDER, 3-1/4 X 4, REPHASING
3	10325	HYDRAULIC CYLINDER, 3-1/2 X 4, REPHASING
4	HYO-2103	PIN, CYLINDER CLEVIS, 1 X 3-1/2
5	135995	COTTER PIN
6	10993	HYDRAULIC HOSE, 1/4 (9/16F) X 122 (6024)
	14844	HYD HOSE, 1/4(9/16F), 147 (FN-6029, FN-6032)
7	10862	HYD HOSE, 1/4(9/16F), 94 (FN-6024)
	10869	HYD HOSE, 1/4(9/16F), 116 (FN-5029, FN-6032)
8	10801	HYD HOSE, 1/4(9/16F), 54

Item	Part Number	Description
9	10806	HYD HOSE, 1/4(9/16F), 78
10	10903	HYD HOSE, 1/4(9/16F), 156 (FN-6024)
	15018	HYD HOSE, 1/4(9/16F), 170 (FN-6029, FN-6032)
11	HYF-1888	HYDRAULIC TEE, 9/16M-9/16M-9/16M
12	15629	HYD HOSE, 1/4(9/16F-3/4ORB), 186
13	15038	HYDRA GRIP, SUPPLY, BLACK
14	15641	HYD DISCONNECT, MALE, 3/4ORB
15	15039	HYDRA GRIP, RETURN, BLACK

## Spur-Till Hydraulic Layout for FN-6000 Series

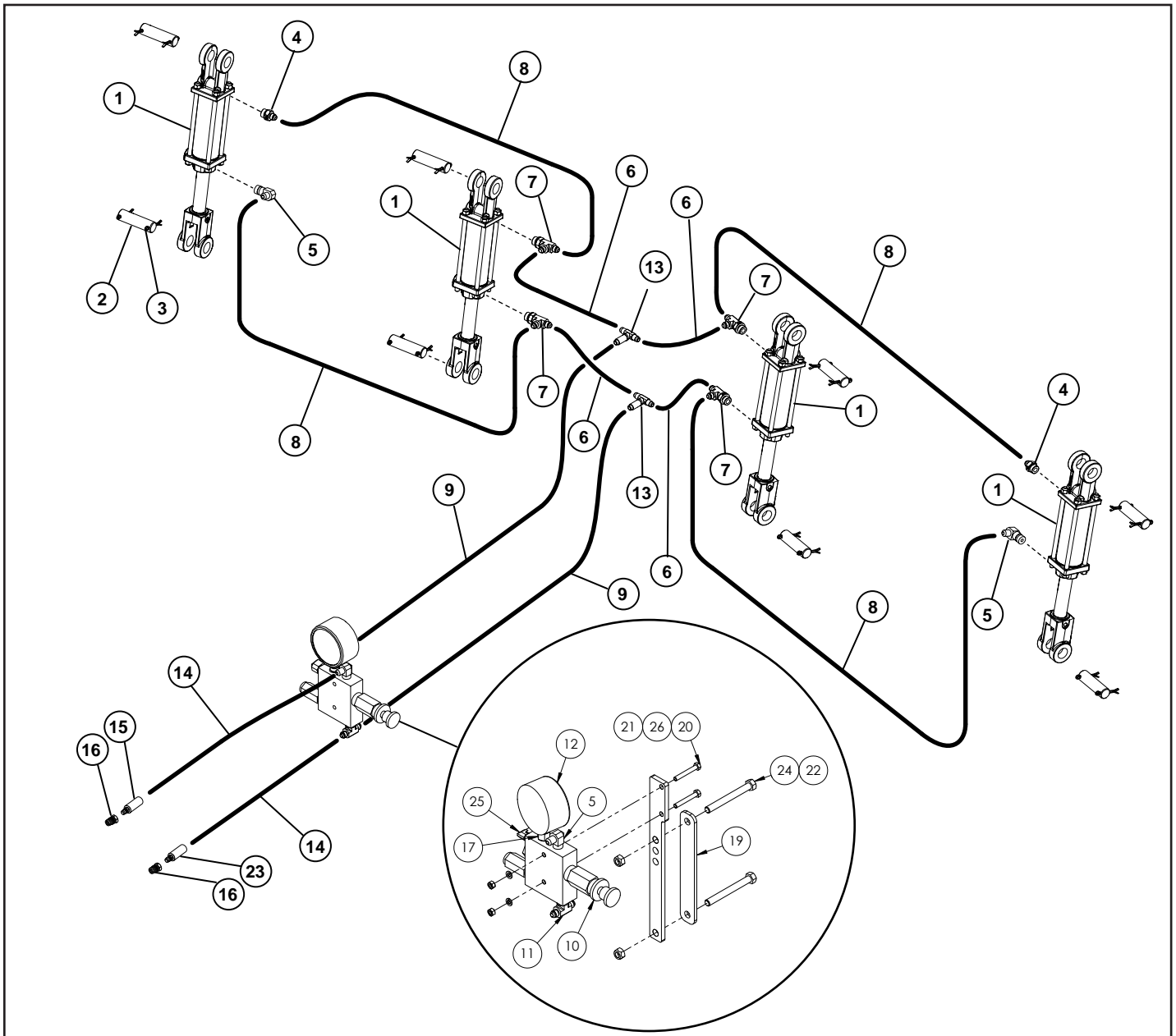

Item	Part Number	Description
1	HYF-32004	HYDRAULIC CYLINDER, 2 X 4
2	HYO-2103	PIN, CYLINDER CLEVIS, 1 X 3-1/2
3	CP-3620	COTTER PIN
4	HYF-3820	HYDRAULIC ADAPTER, 9/16M-3/4Morb
5	HYF-2820	HYDRAULIC ELBOW, 9/16M-3/4Morb
6	10988	HYDRAULIC HOSE, 1/4 (9/16R) X 66
7	HYF-1089	HYDRAULIC TEE, 9/16M-9/16M-3/4Morb
8	10806	HYDRAULIC HOSE, 1/4 (9/16F) X 78 (6024)
	10992	HYDRAULIC HOSE, 1/4 (9/16F) X 102 (6029-6032)
9	14847	HYDRAULIC HOSE, 1/4 (9/16F) X 223
10	14909	RELIEF VALVE
11	HYF-1809	HYDRAULIC TEE, 9/16M-3/4Morb-9/16M
12	14564	GAUGE

Item	Part Number	Description
13	HYF-1888	HYDRAULIC TEE, 9/16M-9/16M-9/16M
14	15630	HYD HOSE, 1/4(9/16F-3/4ORB),204
15	15028	HYDRA GRIP,SUPPLY,GRAY
16	15641	HYD DISCONNECT,MALE,3/4ORB
17	14946	HYDRAULIC ADAPTER, 9/16 Morb - 1/4 Fpipe
18	14919	RELIEF VALVE BRACKET
19	14526	PLATE,CLAMP,8"
20	BH-2525	BOLT, HEX, 1/4-20 X 2.5, GD5
21	NLT-2520	NUT, LOCK, TOP, 1/4-20
22	NLT-5013	NUT, LOCK, TOP, 1/2-13
23	15029	HYDRA GRIP,RETURN,GRAY
24	BH-5045	BOLT,HEX,1/2-13X4.5,GD5
25	HYF-2880	HYD ELBOW,9/16M-9/16Morb
26	LW-0031	WASHER,LOCK 5/16,GD2

# Shank Layout Diagram for FN-6024

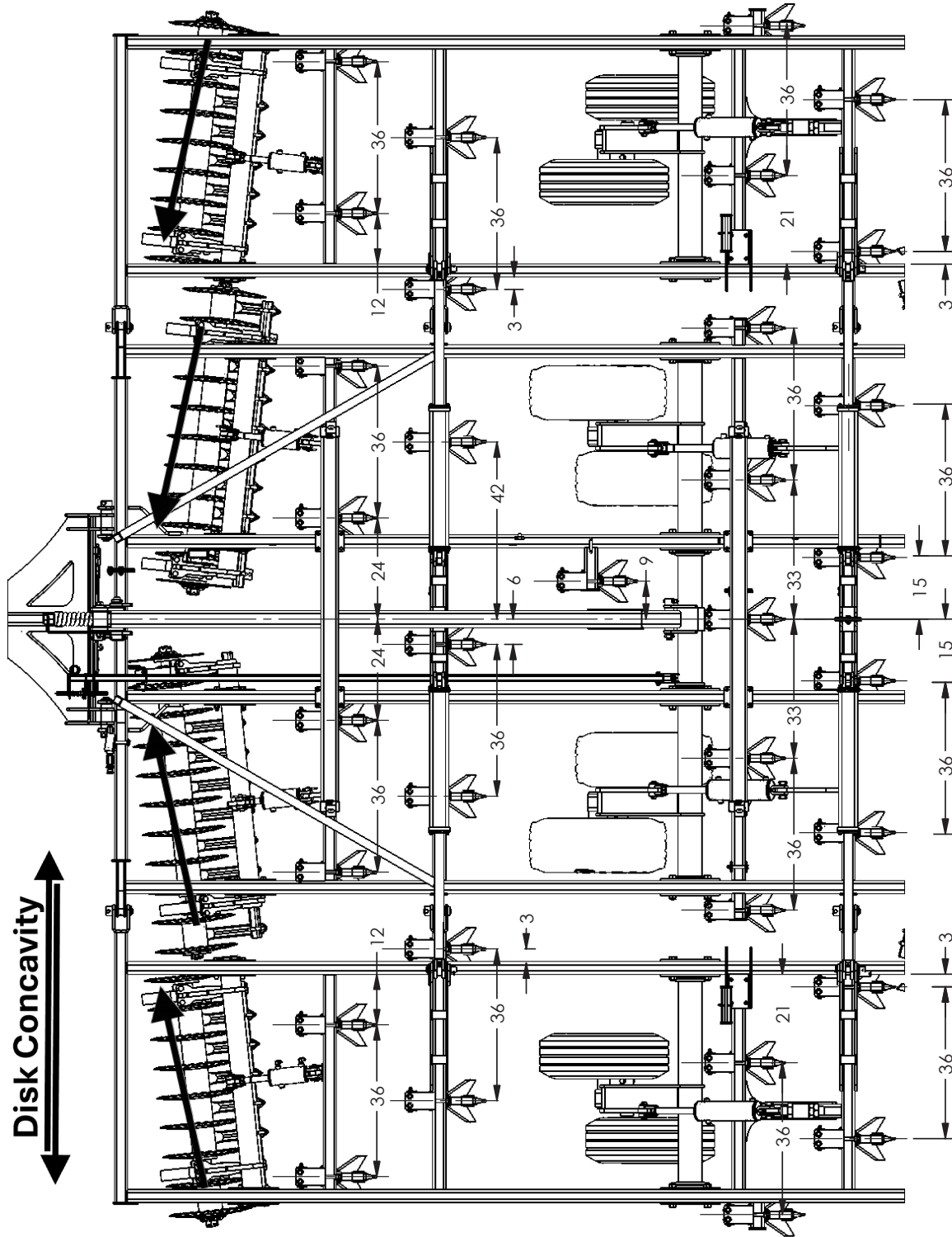

# Spur-Till Layout Diagram for FN-6024

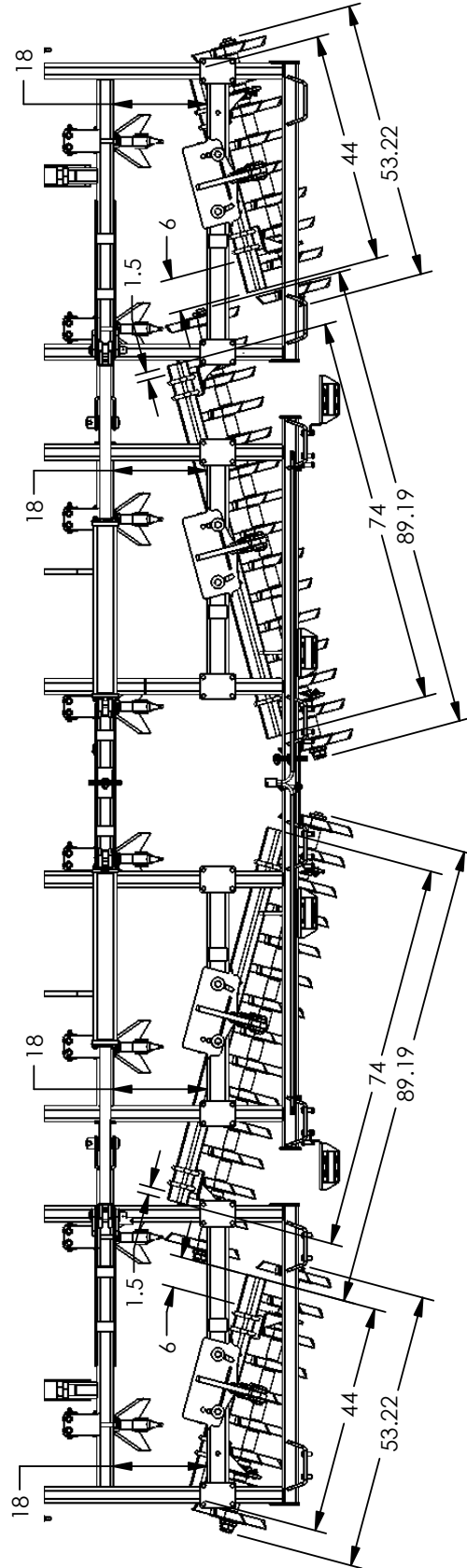

### 3 Bar with Rolling Basket Layout Diagram for FN-6024

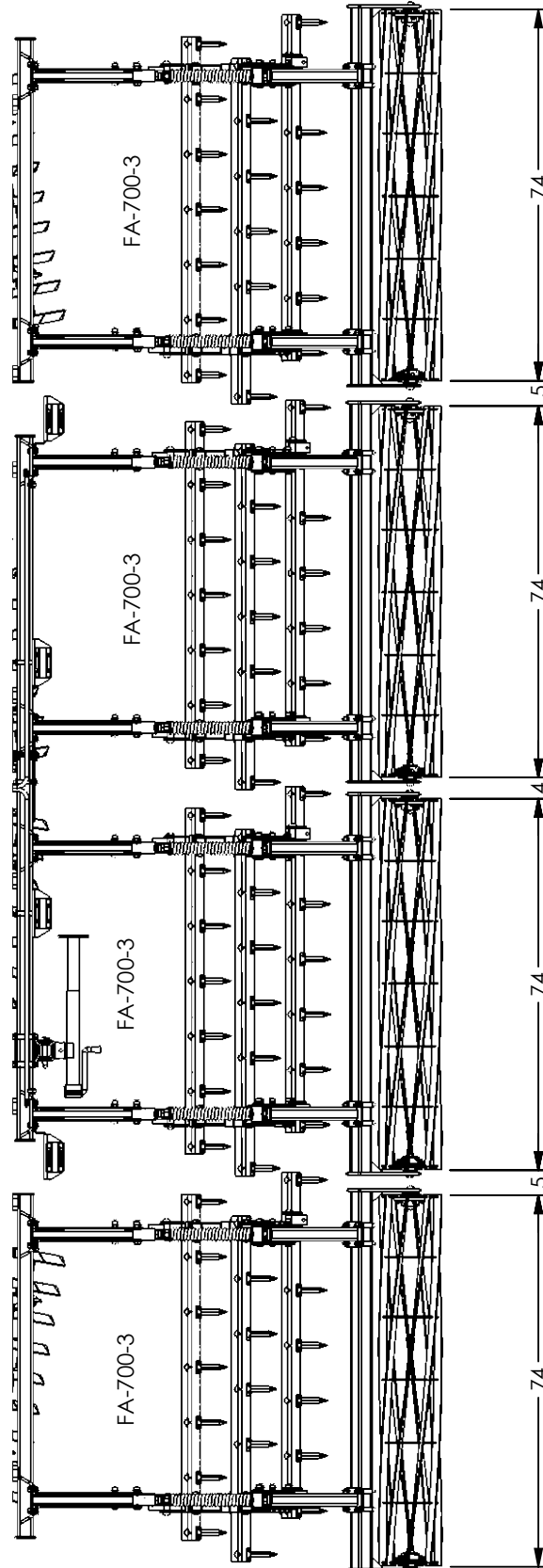

# Shank Layout Diagram for FN-6029

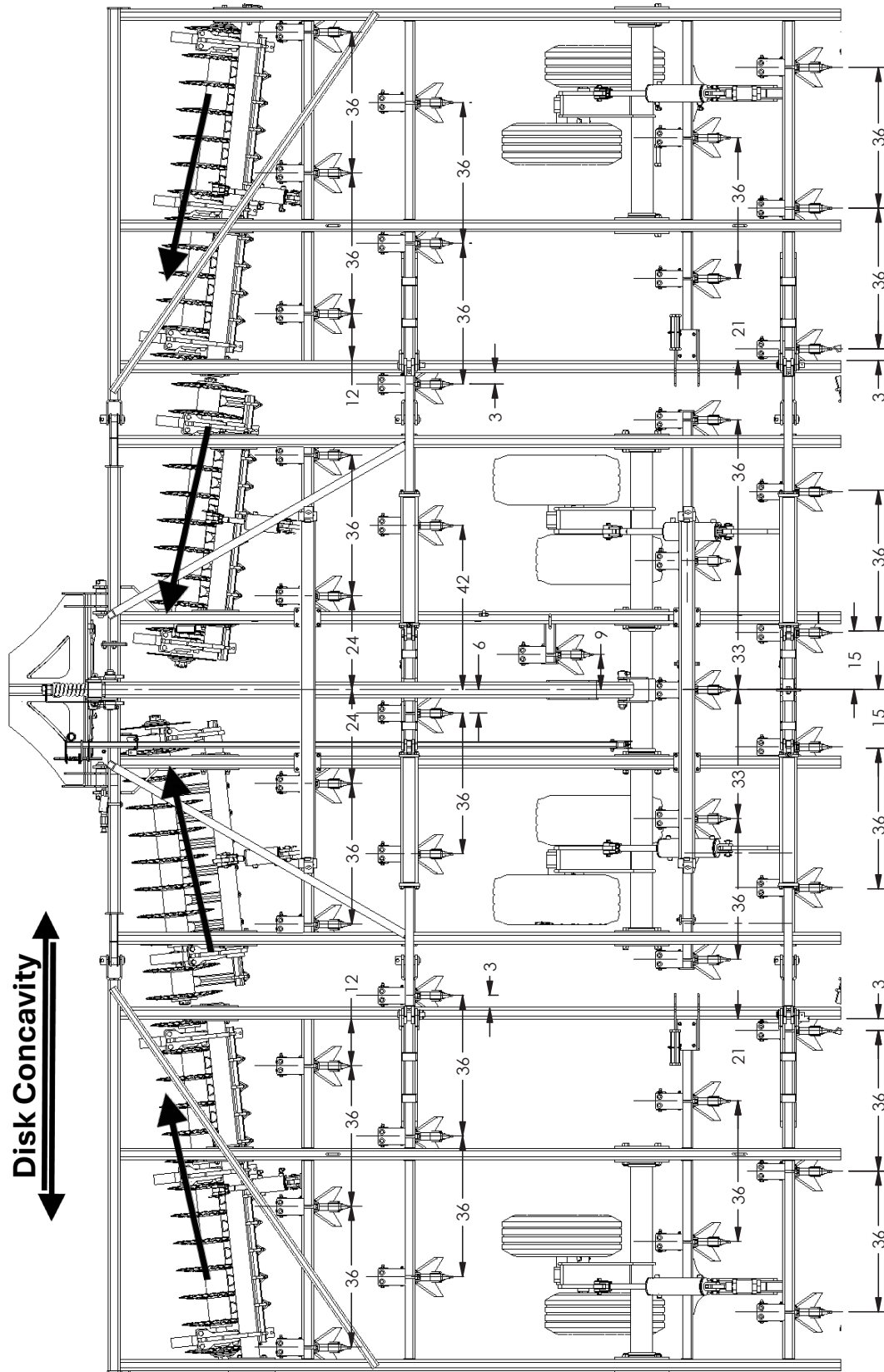

# Spur-Till Layout Diagram for FN-6029

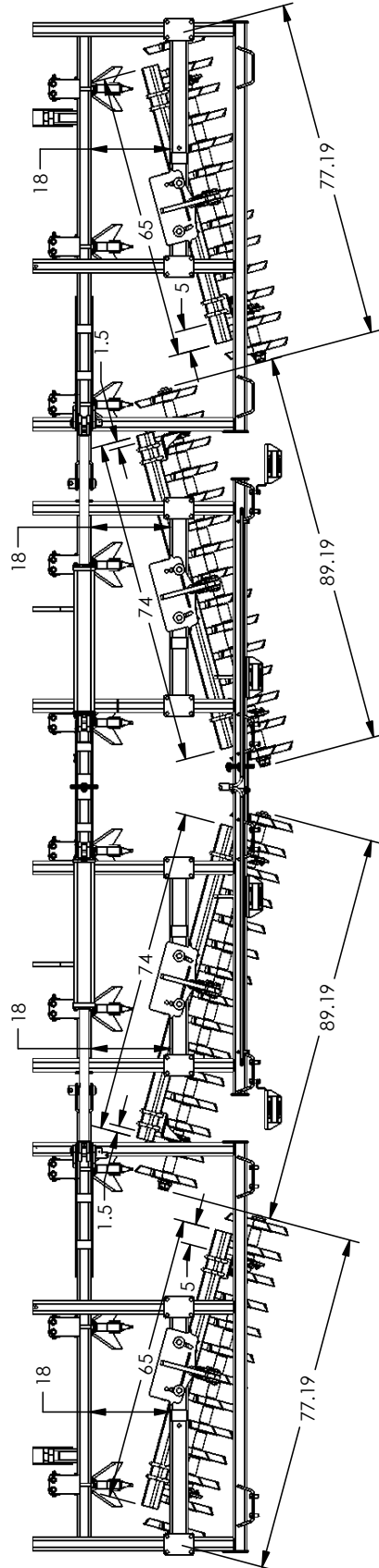

### 3 Bar with Rolling Basket Layout Diagram for FN-6029

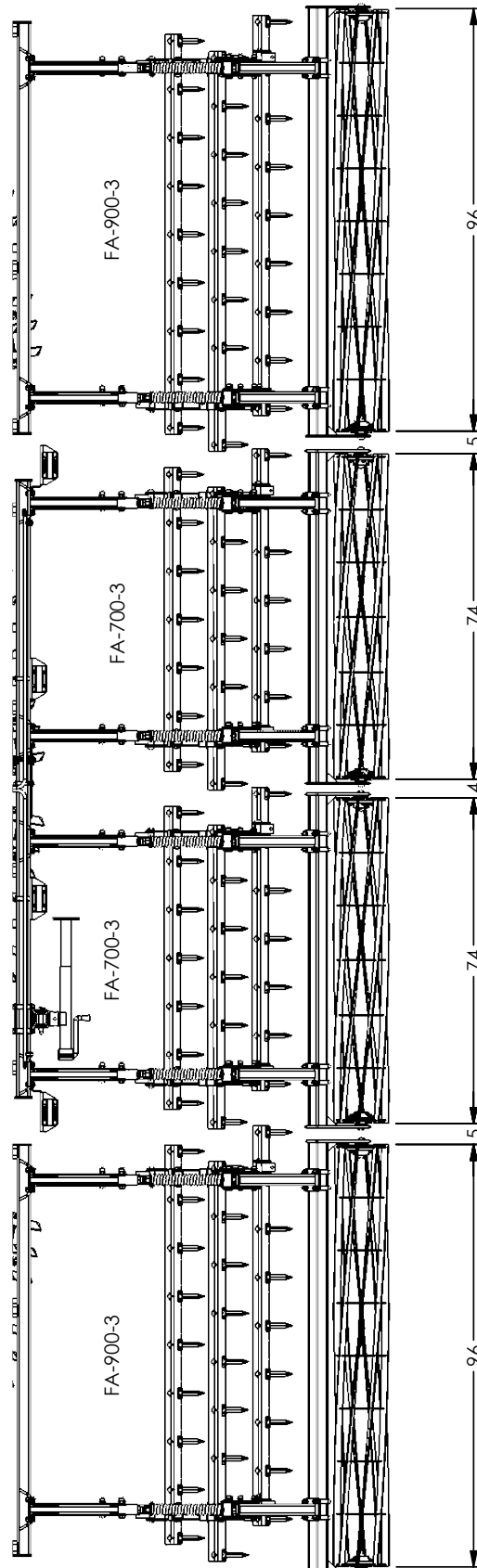



# Spur-Till Layout Diagram for FN-6032

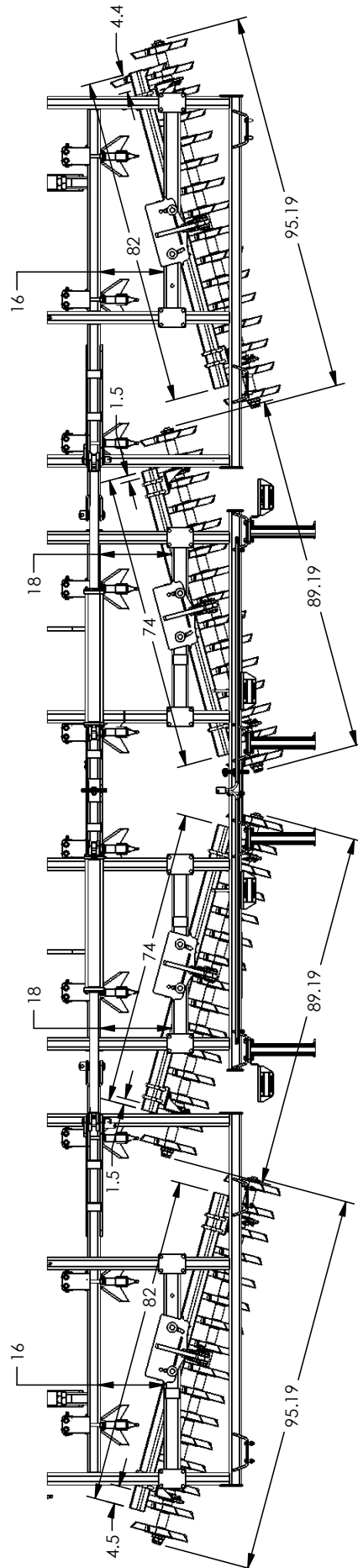

### 3 Bar with Rolling Basket Layout Diagram for FN-6032

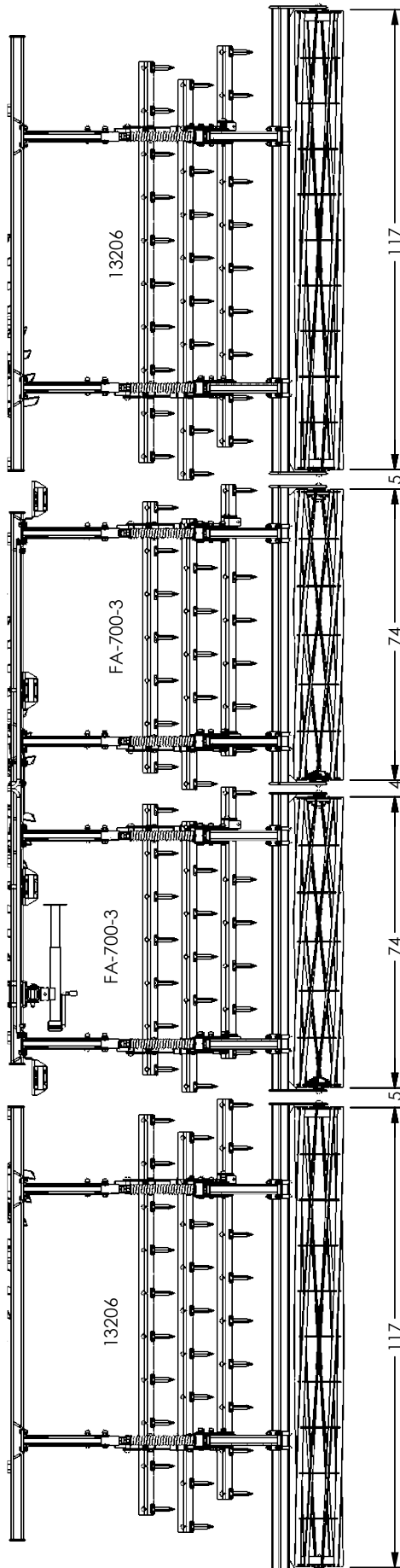

Scan the QR code for a  
digital version of this  
manual



1330 Dallas St  
PO box 100  
Sauk City, WI 53583

Phone: (608) 643.3322  
Toll Free: (888) 627.8569

[mcfarlaneag.com](http://mcfarlaneag.com)

For more information email:  
[info@mcfarlanemfg.com](mailto:info@mcfarlanemfg.com)

Member of:

**FARM EQUIPMENT  
MANUFACTURERS  
ASSOCIATION**

Copyright 2026 McFarlane Mfg.

Last revised: 03/06/2026

