



# kirei

## DIAMOND TILES

### Acoustic Tiles

Minimize noise reflection from hard surfaces with the sophisticated style of Diamond Tiles. A beautiful fusion of acoustics and aesthetics, Diamond Tile's 187 in<sup>3</sup> of airspace provides superior sound absorption at lower frequencies. Comes in single, 2-, 5- and 10-diamond clusters for more on-wall placement versatility. Easy to install using construction adhesive and is available in a variety of colors from neutral to vibrant tones. Customization is also available for your unique design concepts.

Product shown: Diamond Tiles in Frost, Ochre, Ivy, Jade, Navy, Smoke, Pacific, and Coronet

# Specs

Style	Standard (LxH)	Depth	Weight/Unit	SF/Unit
Single Diamond	13.9" x 12"	6.5"	1 lb	0.87
2-Diamond Cluster	13.9" x 24.1"	6.5"	2 lbs	1.74
5-Diamond Cluster	24.4" x 36.1"	6.5"	5 lbs	4.36
10-Diamond Cluster	45.2" x 36.1"	6.5"	10 lbs	8.74

All specs refer to singular products and not multiples unless specified. Due to the nature of the material, cutting and fabrication process, minor dimensional variances may occur.

Designer Kirei

Material Thickness 12mm

Material 100% PET (60% post-consumer recycled content)

Fire Rating ASTM E84 Class A

Custom Options Available upon request

Lead Time Please refer to [kireiusa.com](http://kireiusa.com) for updated lead times.

VOC Emissions CDPH (CA 01350) Compliant  
TVOC: <0.5 mg/m3



\*Actual lead times are determined when the project goes into production and can change based on production schedule and all quantities, color and thicknesses being in stock at time of order. See [Kirei's Product Lead Time Disclosure](#) for more information.



# Acoustic Data

## Sound Absorption

Frequency	250Hz	500Hz	800Hz	1000Hz	2000Hz	4000Hz	NRC
m <sup>2</sup> /Object	5.27	6.22	5.49	5.72	5.77	6.11	1.05

Acoustic data is measured in Sabins per Diamond Tile.

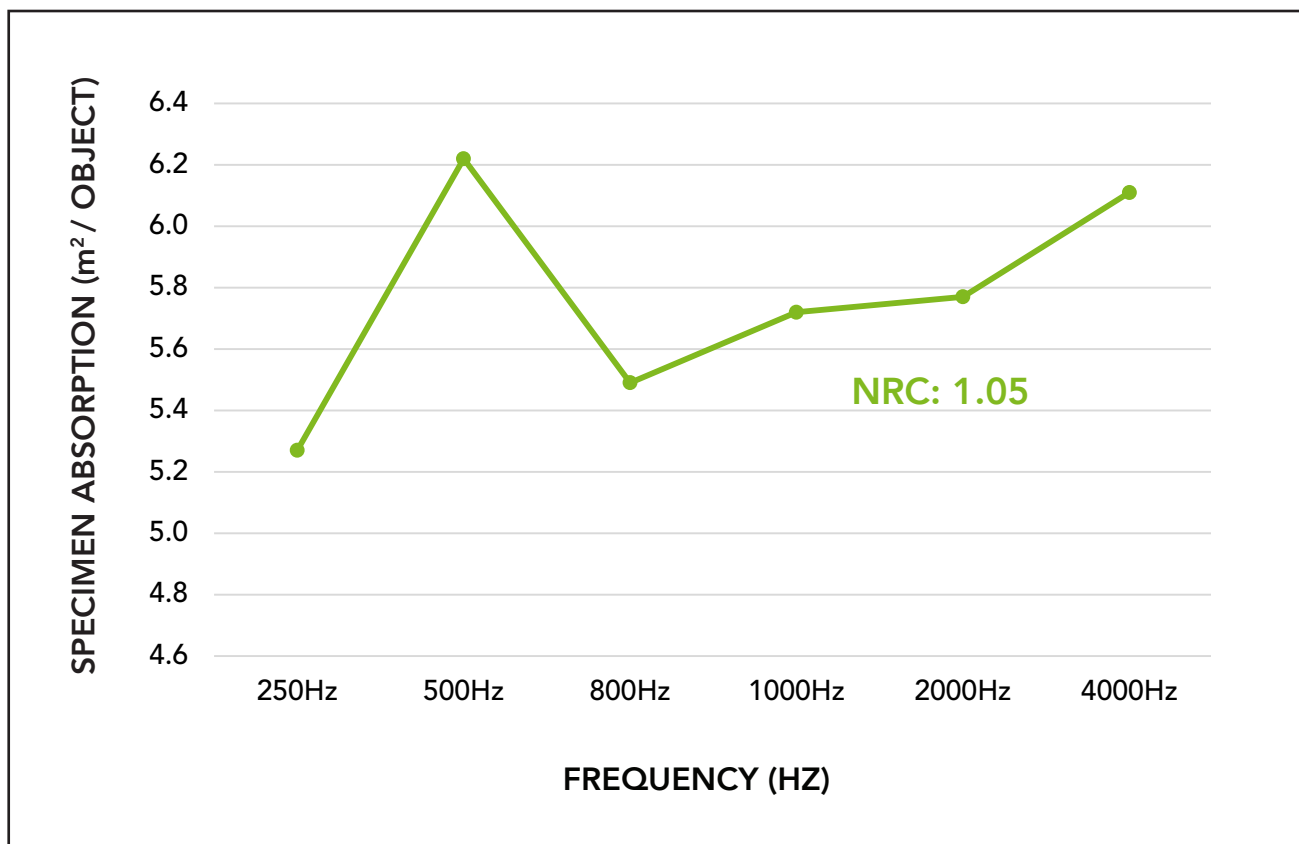

# Product Dimensions

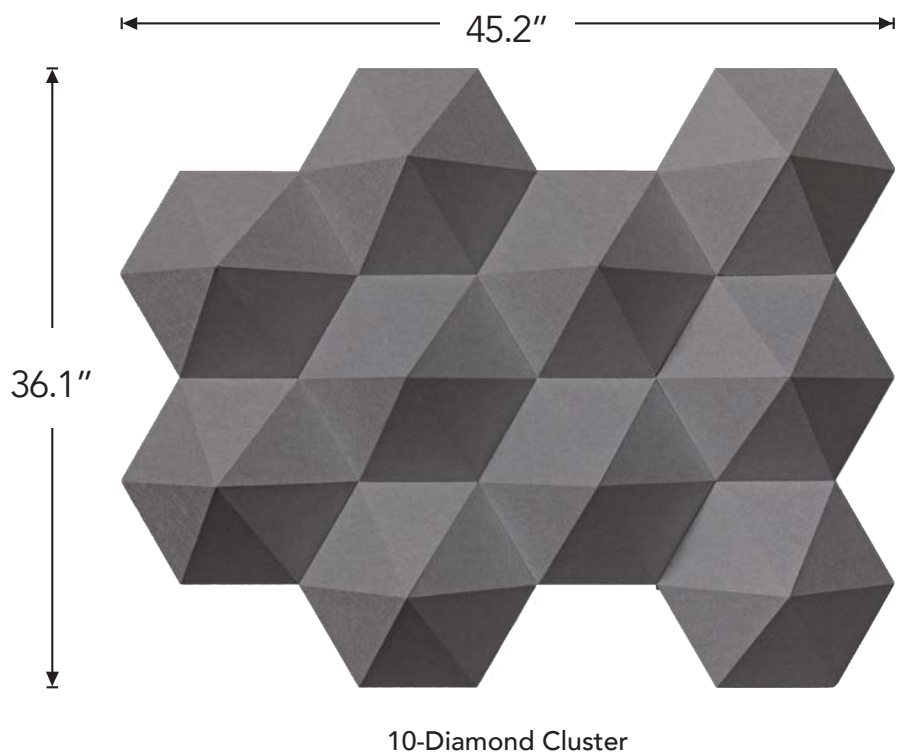
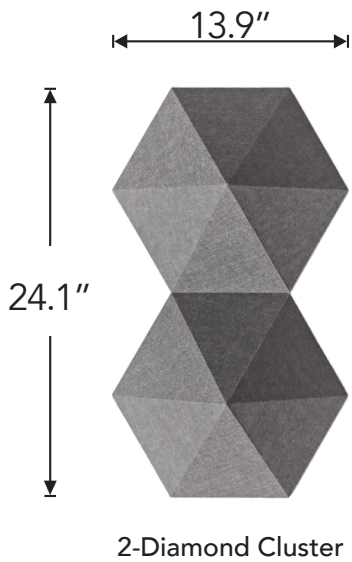
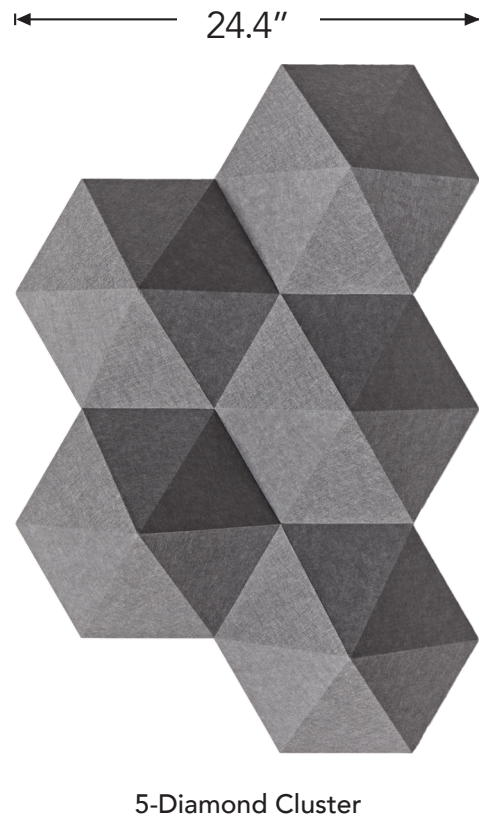
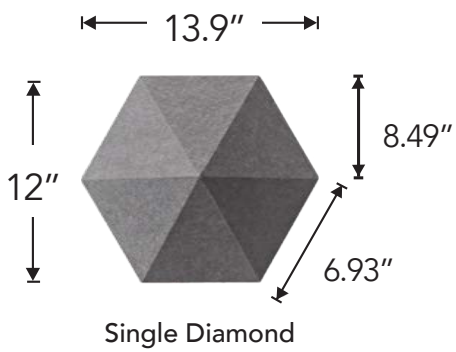
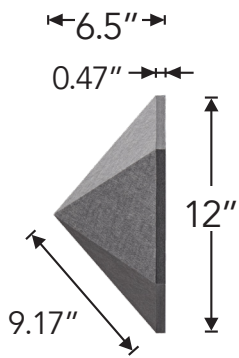

# Product Side View

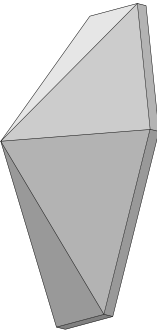

Single Diamond

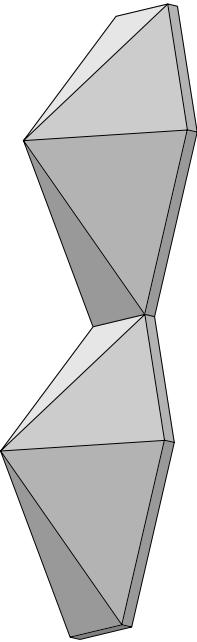

2-Diamond Cluster

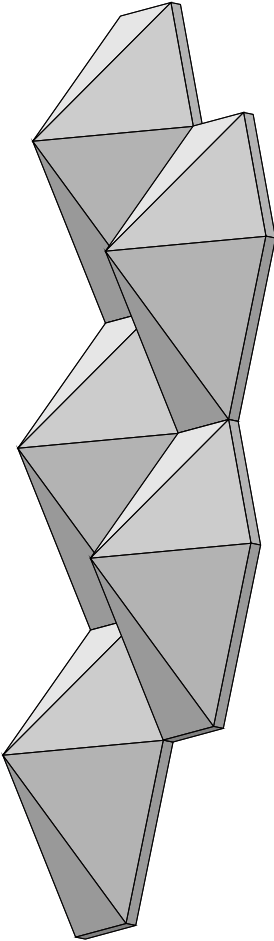

5-Diamond Cluster

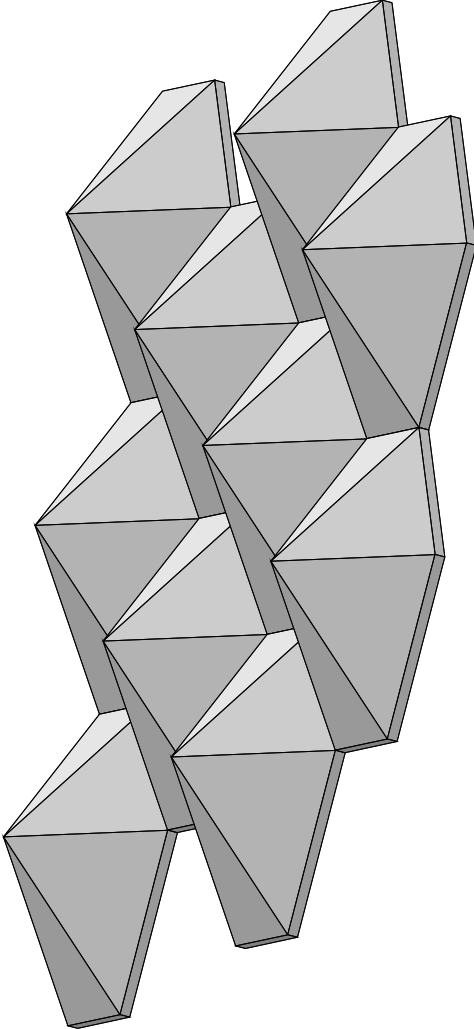

10-Diamond Cluster

# Available Colors



Color variation between dye lots is a natural characteristic of recycled PET felt due to the manufacturing process. Slight differences between samples and finished product may occur.

# Installation

When mounting, use standard construction adhesives (e.g. Liquid Nails/Titebond - NOT PVA glue). Clean and prepare surface per adhesive guidelines. Spread adhesive evenly on panel back, leaving 2" space at edges. Adhere to wall surface, providing bracing to hold material against surface per adhesive open time/instructions. For more information, see the [Diamond Tiles Installation Guide](#).

## Custom Printing with Kirei Ink

Diamond Tiles can be custom printed in house with Kirei Ink. We would love to work with you to print your own custom color, pattern, graphic or material. Reach out and our team will be ready to assist!

Please note: Kirei requires written permission from the copyright holder in order to reproduce any copyrighted work. Professional photographs cannot be reproduced without written permission from the photographer.

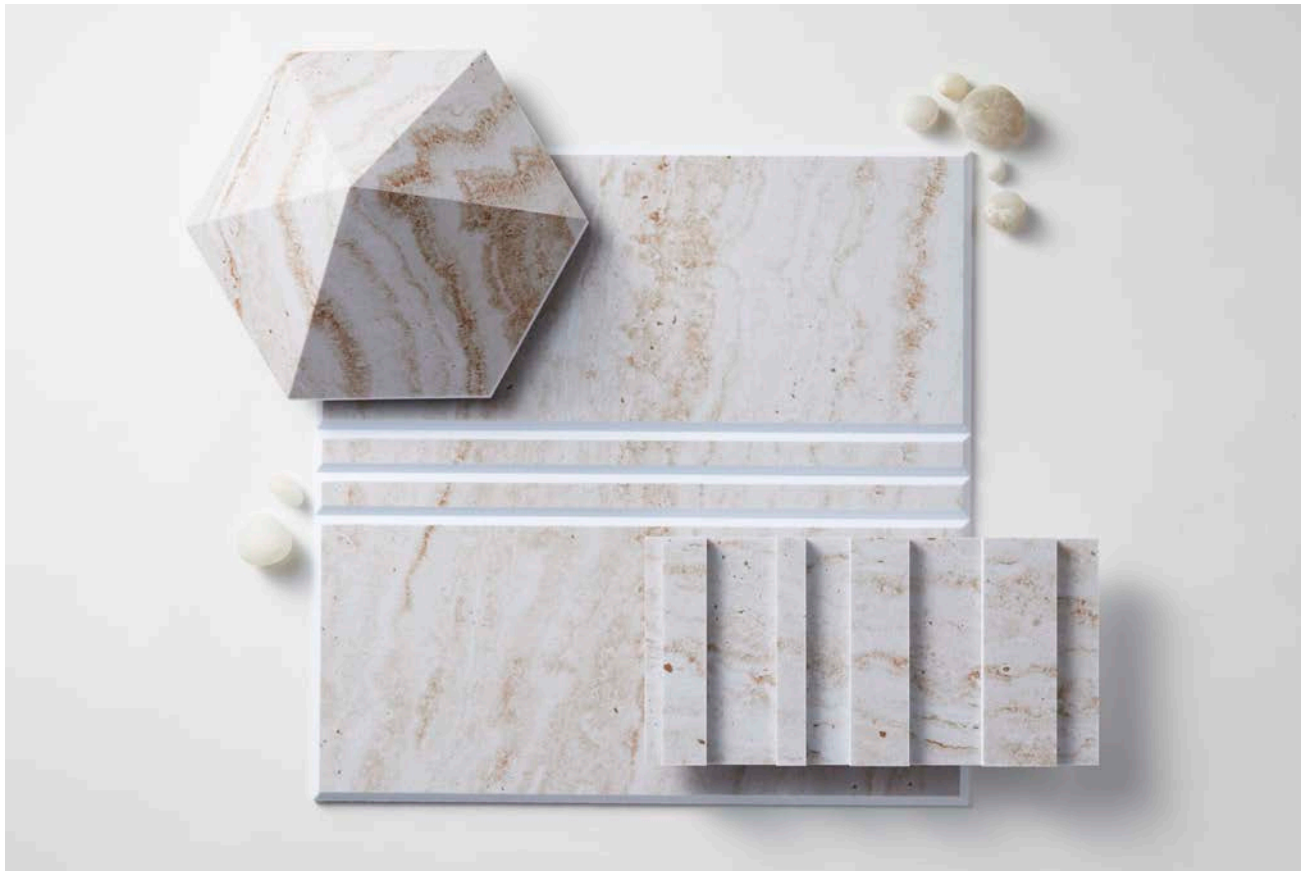

Product shown: Diamond Tile, Racetrack Path Tile, and Barcode Tile with Kirei Ink (Travertine)



Diamond Tiles in Ivy and Navy



Product shown: Diamond Tiles in Coronet



Product shown: Diamond Tiles in Smoke



Product shown: Diamond Tiles in Ochre, Navy, and Vineyard

# kirei

Learn more and request your free sample:

619.236.9924 | [sales@kireiusa.com](mailto:sales@kireiusa.com)

[kireiusa.com](http://kireiusa.com)