

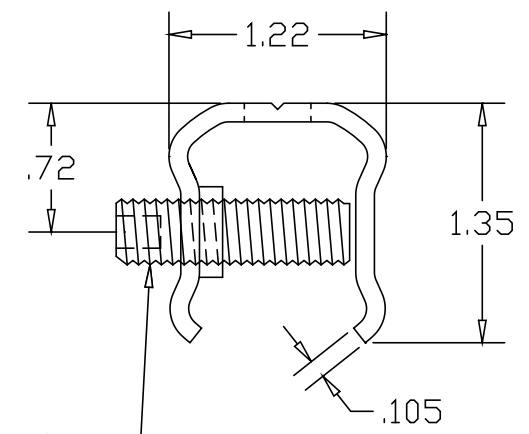

REVISIONS			
REV	DESCRIPTION	DATE	APPROVED

Ø.375 (2) PLACES
FOR MFR ONLY

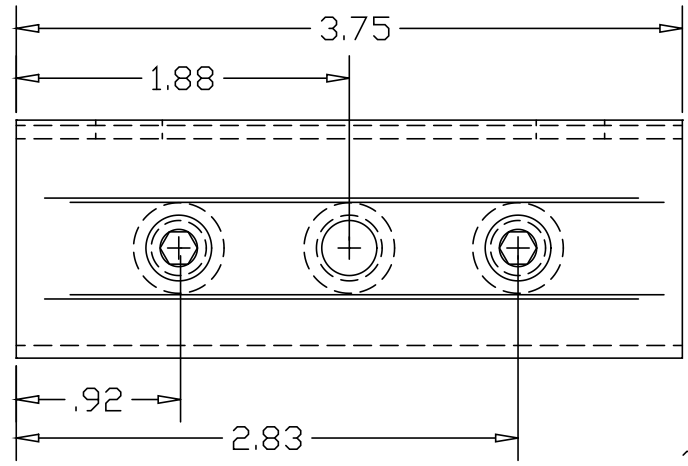
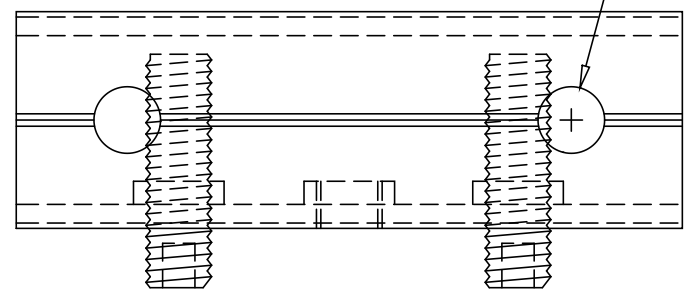

3/8-16 X 1.38
SOCKET SET-SCREW
(2) PLACES

PART NAME 1-1/2" SCH 40 DOUBLE LOCK ONE PIECE SPLICE LOCK			
MATERIAL			
DATE 08/12/09		THE WAGNER COMPANIES R & B WAGNER, INC. AND J. G. BRAUN CO.	
DRAWN BY PWH			
FINISH AS STAMPED	SIZE A	WEIGHT .36 LBS	PART NUMBER G3358S
			REV