

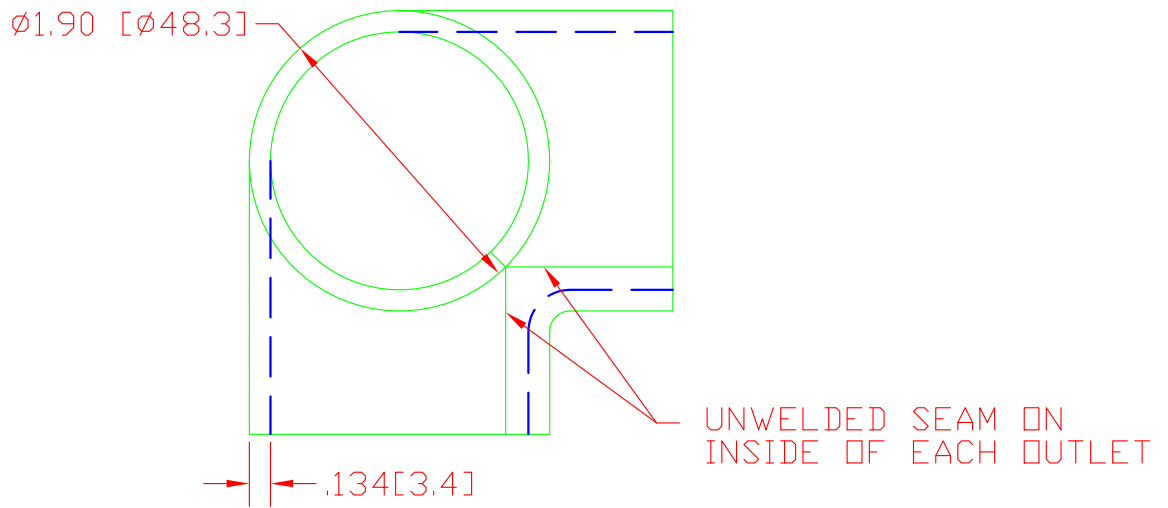

REV
SH
DWG NO
841

REVISIONS			
REV	DESCRIPTION	DATE	APPROVED

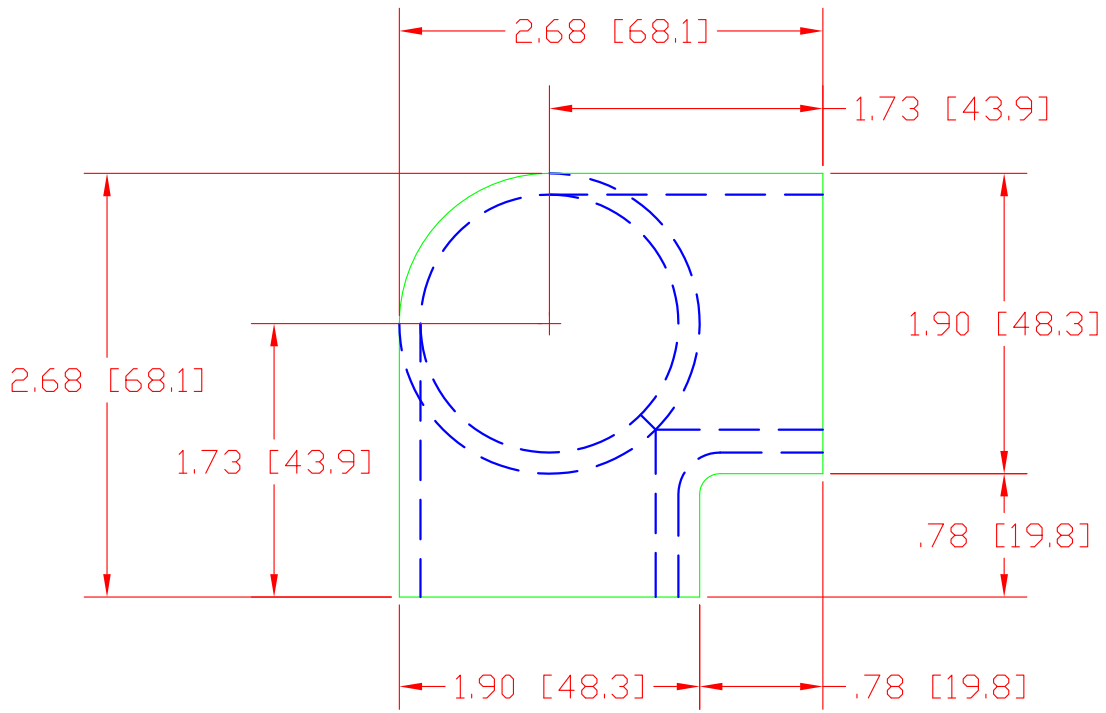

INCHES[MILLIMETERS]

ALTERNATE MATERIAL	PART NUMBER
.125 (3003) ALUMINUM ASTM B209	843
10 GA. (304) STAINLESS STEEL ASTM A240	845

PART NAME		1-1/2" PIPE SIZE SIDE OUTLET ELL	
MATERIAL		10 GA. HRP&D STEEL ASTM A569	
DATE	6/14/95	 THE WAGNER COMPANIES R & B WAGNER, INC. AND J. G. BRAUN CO.	REV
DRAWN BY	RJF		
FINISH	MILL		
SIZE	WEIGHT	PART NUMBER	REV
A	.81 LBS	841	