

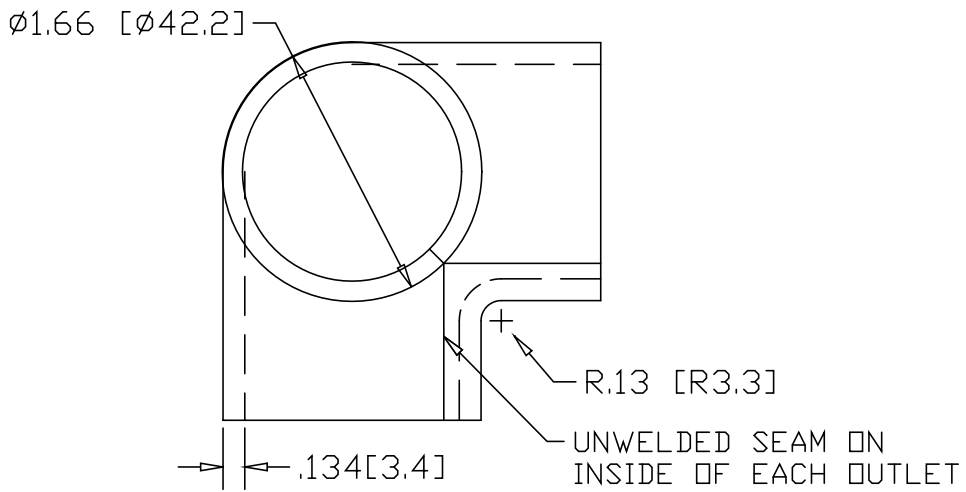

REV
SH
840
DWG NO

REVISIONS			
REV	DESCRIPTION	DATE	APPROVED

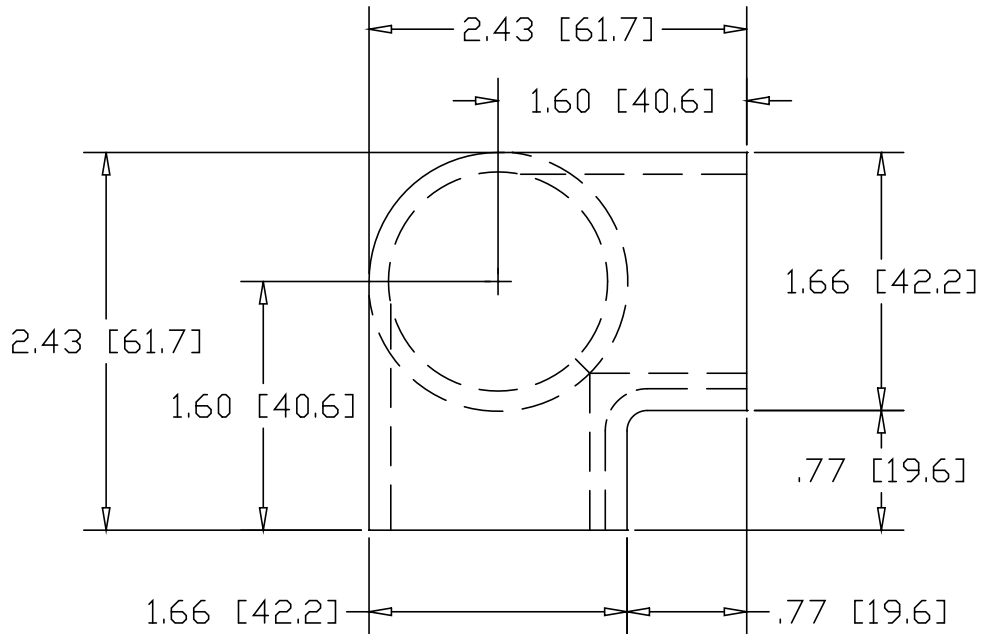

INCHES[MILLIMETERS]

ALTERNATE MATERIAL	PART NUMBER
.125 93003 ALUMINUM ASTM B209	842
10 GA. (304) STAINLESS STEEL ASTM A240	844

PART NAME		1-1/4" PIPE SIZE SIDE OUTLET ELL					
MATERIAL		10 GA. HRP&D STEEL ASTM A569					
DATE	6/14/95	 THE WAGNER COMPANIES R & B WAGNER, INC. AND J. G. BRAUN CO.					
DRAWN BY	RJF						
FINISH	MILL						
SIZE	A	WEIGHT	.69 LBS	PART NUMBER	840	REV	