

# ARES ULTRA BT

## RANGE

Electromechanical automation for rack sliding gates up to 75'

### ARES 1000/1500

P926193 00001- ARES ULTRA BT A1000 120V

-Gates up to 2,200lbs.

P926191 00001 – ARES ULTRA BT A1500 120V

-Gates up to 3,300lbs.

- ARES 1000 and ARES 1500 operators widen the BFT range of sliding gate operators. Rated with the “medium-heavy” weight range, they integrate with existing products to obtain an operator that is perfectly suited to the gate every time.

## LOW VOLTAGE MOTOR

- The 24V electrical motor guarantees maximum accuracy in torque and speed control. It is suitable for intensive gate use. Optional battery back-up can be fitted within the operator casing. These operators are all “Ecosol” solar compatible.



24 V ee link

## TECHNICAL FEATURES

	<b>ARES 1000</b>	<b>ARES 1500</b>
Control panels	Merak (incorporated)	Merak (incorporated)
Reversible/irreversible operator	irreversible	irreversible
Power supply	120 V 60 Hz single-phase	120 V 60 Hz single-phase
Absorbed power	240W	400W
Thermal protection	integrated	integrated
Leaf Speed	5.9 ips	5.9 ips
Pinion Pitch	4 mm (18 teeth)	4 mm (18 teeth)
Impact reaction	electronic torque limiter	electronic torque limiter
Manual release	Lever-operated with key	Lever-operated with key
Operating cycle	intensive use	intensive use
Environmental conditions	-4°F to 131°F	-4°F to 131°F
Degree of protection	IP44	IP44
Operator weight	20 lbs	20 lbs
Limit switches	magnetic	magnetic



Be ahead

BFT Americas, Inc.  
6100 Broken Sound Parkway N.W.  
Boca Raton, FL 33487

T: +1 561 995 8155  
T: US. 1877 995 8155  
info.bft@bft-usa.com  
www.bftaccess.com  
www.bft-usa.com

# ARES ULTRA BT

## DIMENSIONS

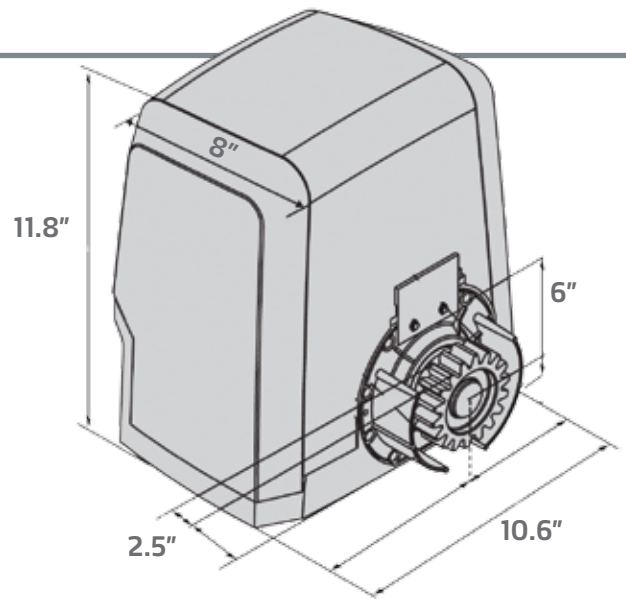

## ACCESSORIES



**PI25035- SL BAT2**  
24V DC battery backup system for DEIMOS BT A, ARES BT A, DEIMOS ULTRA BT A, ARES ULTRA BT A, it includes a charger board that activates the batteries when the power is off and charges the batteries when the power is on.



**P111468, B EBA**  
Two serial connection interfaces required for MERAK UL board master and slave connections.



**D221073- CP**  
22x22 4mm-pitch plastic rack with adjustment slots. 3' 3" length.



**D571053 - CVZ**  
30x12 4mm pitch galvanised adjustable steel rack 3' 3" length.



**D730298 - 25 TEETH PINION**  
Larger pinion for increased speed (7.9ips). Max gate weight Ares 1000 1100lb (500Kg) & Ares 1500 1650lb (750Kg).



**CELLBOX PRIME**  
3G Cellular access control system with 7 day time clock



**I700032 10001**  
Merak control board



**D111904 Mitto 2**  
**Transmitter:**  
12V Two channel 433Mhz rolling code remote control



**P121024 - Q-BOX**  
Digital keypad with 10 channels and 100 combinations. Backlit



### KED113731H - ECOSOL KIT

Includes Ecosol Interface, solar panel and 15' solar of panel cable, connection harness for easy installation, for running BFT control panels off 24V solar power. Includes two 12V 7.2Ah batteries and circuit board for management of commands to control panel and battery charge management, with built-in Rolling Code 433.92 MHz receiver with 63 stored positions.



Be ahead

BFT Americas, Inc.  
6100 Broken Sound Parkway N.W.  
Boca Raton, FL 33487

T: +1 561 995 8155  
T: US. 1877 995 8155  
info.bft@bft-usa.com  
www.bftaccess.com  
www.bft-usa.com