



RBAND

MONITORED GATE EDGE TRANSMITTER/RECEIVER

INSTALLATION INSTRUCTIONS

In partnership with
jcmotech

Model: RB-G-K10



GATE

MillerEdge®

IMPORTANT: READ AND UNDERSTAND ALL INSTRUCTIONS BEFORE BEGINNING INSTALLATION

The Miller Edge RBand Monitored Gate Edge Transmitter/Receiver system is intended to provide a wireless connection between a monitored sensing edge and a motorized operator that controls the associated gate. RBand meets the 2016 UL 325 requirements for monitored devices and has been certified as a UL 325 Recognized Component. It is designed for use with operators that comply with 2016 UL 325 using a Miller Edge 10K Sensing Edge.

1. PARTS LIST

Kit Contents:

1. RBand Edge Transmitter (RB-TX10)
2. RBand Gate Edge Receiver (RB-G-RX10)
3. Receiver antenna
4. (2) 3.6V AA lithium batteries*
5. (4) #6 pan head transmitter mounting screws

*Replacement 3.6V AA lithium batteries can be purchased at your local electronics store or via Miller Edge.

Required:

- 1/8" flat blade screwdriver
- 1/4" flat blade screwdriver
- Miller Edge 10K (T2/blue band) Sensing Edge
- Coaxial cable for exterior mounted antenna
- Coaxial bulkhead adapter, female/female

Recommended:

- Multi-meter capable of reading 10KΩ
- Mounting screws as required for receiver

2. RECEIVER: INSTALLATION

- 2-1. Remove operator cover and turn off the power to the gate operator.
- 2-2. Determine where to place the external mounted antenna so it is in line of sight with the Transmitter for the entire range of travel [IMAGE 1]. Prepare the antenna coax as necessary.
- 2-3. Remove Receiver cover and mount the base inside the operator, positioning it for optimum ease of wiring.
- 2-4. Connect power to the terminals marked **12/24 AC/DC** (polarity sensitive) on the **removable 8-pin connector** [IMAGE 2].
- 2-5. Determine which monitored interface your operator uses. Connect the **COM (C1/C2)** and the correct output connections (**N.C. = CS1/CS2** or **10K = BS1/BS2**) to your operator. There are 2 separate relays (channels): **R1** and **R2**. The **A Test** terminals must be used for operators requiring N.C. inputs. Enable with **DIP switch 4** [TABLE 1].
- 2-6. Replace the Receiver cover and turn on power to the operator. Note: it takes ~5 seconds for the Receiver to initialize.

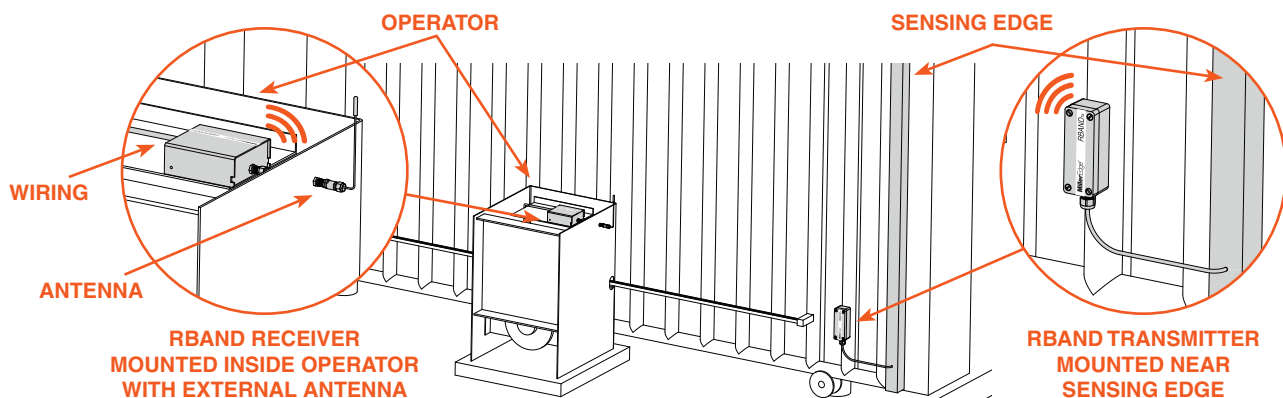
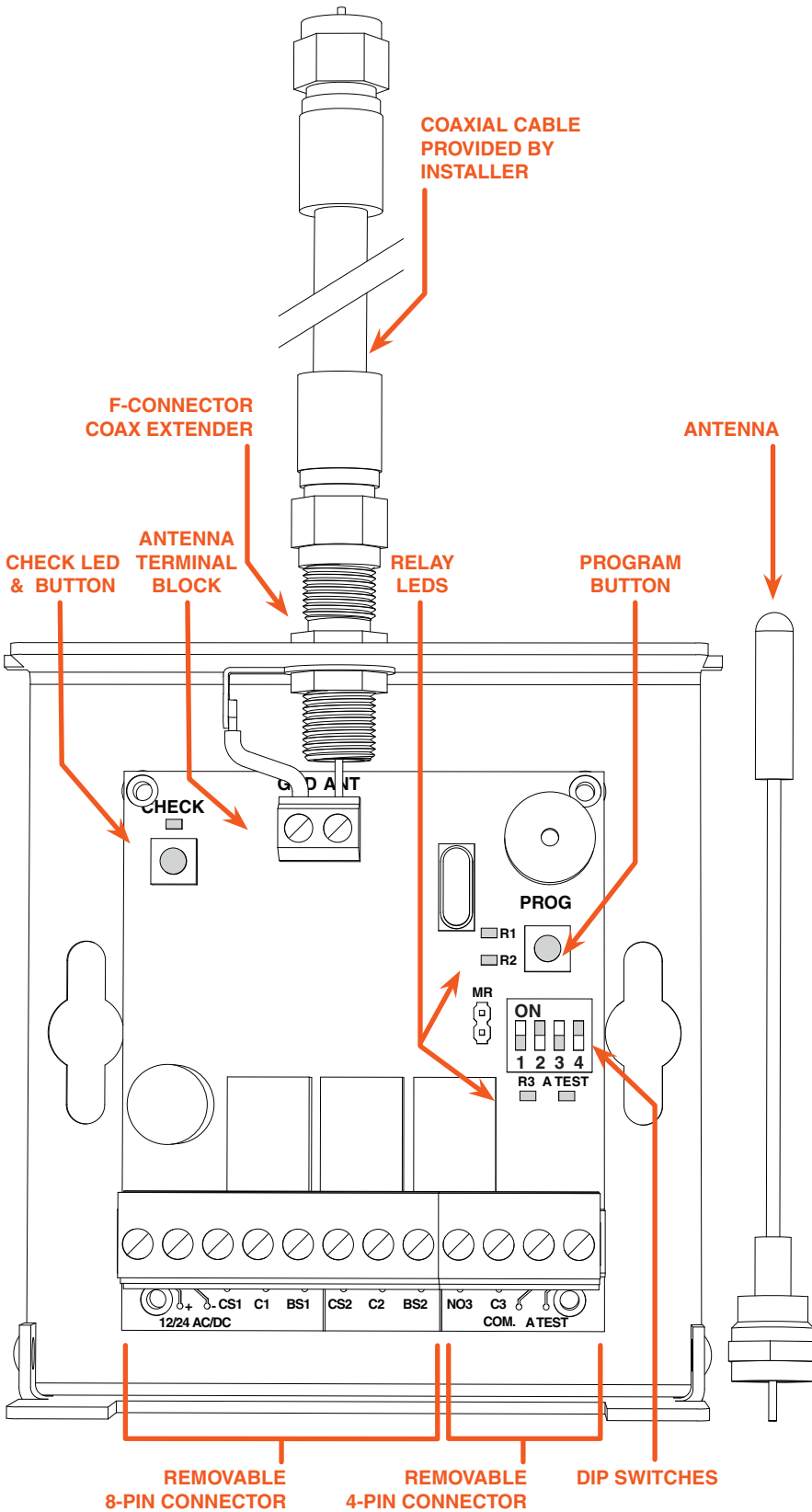

IMAGE 1. RBand Transmitter Installation with Gate Edge

RB-G-K10_Install_20170328



LED INDICATORS

Initial Power

- No Transmitters Programmed: R1 & R2 LEDs on

R1 or R2 LED

- Programmed: **Off**
- Fault Condition: **On**

R3 LED

- On** when battery is low

A TEST LED

- On** when in test mode

CHECK LED

(both channels programed)

- Programmed: Check LED flashes every 5 seconds

DIP SWITCH SETTINGS

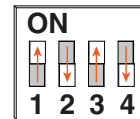

Switch 1-3: Leave switches in factory default settings

Switch 4: Used to enable Normally Closed cycle testing:

- N.C. Operator: Set to **on** and connect the switched power to the **A Test** and **Common** pins shown above
- 10K Operator: Set to **off**

TABLE 1. REMOVABLE CONNECTORS

For Normally Closed gate operators, please reference page 5.

8-PIN CONNECTOR

Power

- +12/24 AC/DC ▶ Constant power source
- 12/24 AC/DC ▶ Constant power source (ground)

Relay Output 1

- CS1 ▶ N.C. monitored input
- C1 ▶ Monitored input Common
- BS1 ▶ 10K monitored input

Relay Output 2

- CS2 ▶ N.C. monitored input
- C2 ▶ Monitored input Common
- BS2 ▶ 10K monitored input

4-PIN CONNECTOR

Relay Output 3

- NO3 ▶ Low battery alarm (optional)
- C3 ▶ Low battery alarm (optional)

N.C. Power Cycling

- COM. ▶ COM: Switched power Common
- A TEST ▶ +12/24VDC: Switched power source

IMAGE 2. R BAND GATE EDGE RECEIVER PCB & CONNECTIONS

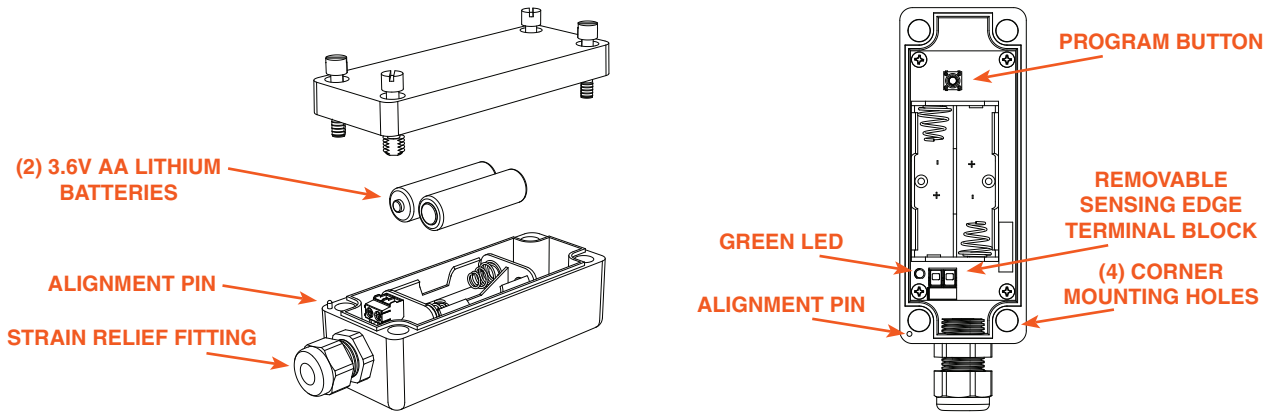

Note: RBand 10K Gate Edge Receiver is compatible with up to 3 RBand Transmitters on 2 channels (6 total).

IMAGE 3. RBand Edge Transmitter PCB & Connections

3. TRANSMITTER: PROGRAM MODE

- 3-1. Confirm the Receiver is powered up. Prior to mounting the Transmitter, remove the cover and insert the batteries, noting their polarity. The **green LED** on the Transmitter should blink to indicate that it has not been associated with the Receiver yet [IMAGE 3].
- 3-2. To enter **learn** mode, press and hold the Receiver **program button** for ~2 seconds until the **R1 LED** turns on, then release the button [IMAGE 2].
- 3-3. Press the Transmitter **program button** for ~2 seconds [IMAGE 3]. The Receiver should **beep**. Wait 10 seconds for an additional **beep** to indicate that programming is complete.
- 3-4. To program a Transmitter to Channel 2, press and hold the Receiver **program button** until the second **beep**, then release the button. The **R2 LED** should be on [IMAGE 2]. Repeat 3-3.

4. TRANSMITTER: INSTALL & TEST

- 4-1. Strip back approximately 2 inches of outer covering of sensing edge cable, then feed through Transmitter **strain relief fitting**. Connect the two sensing edge wires to the removable terminal. Dress the wires with a small service loop and tighten the strain relief. Mount unit utilizing the mounting holes at the 4 corners of the Transmitter box. Affix lid to Transmitter, noting the **alignment pin** [IMAGE 3].
- 4-2. Test the sensing edge for functionality.

5. TROUBLESHOOTING

If the Receiver does not react to the Transmitter, you can check the RF signal strength:

- 5-1. Press the **check button** on the Receiver for ~2 seconds [IMAGE 2]; 4 beeps will be heard. You then will hear a beep every 1-1/2 seconds during the **check** process. Wait about 30 seconds; if no other beeps occur, your system is functioning. 3 quick beeps indicates a communication error.
- 5-2. Activate the sensing edge and observe the **check LED**; 3-5 flashes is ideal. Less than 3 flashes means there is a weak signal.
- 5-3. To exit **check** function, press the **check button**, or system will time-out after 5 minutes. There will be a series of beeps heard upon exiting.

6. ERASING THE RECEIVER

If you need to replace a Transmitter or you have any other programming issues, you may need to erase the Receiver.

- 6-1. To erase any Transmitters programmed into the Receiver, use a screwdriver to short the two pins marked **MR** next to the **DIP switches** [IMAGE 2].
- 6-2. While shorting the pins, press and hold the **program button** for several seconds; you will hear a series of 10 beeps followed by a rapid chirping sound.
- 6-3. When the chirping stops, release the **program button**. Wait ~10 seconds and you will hear 2 beeps. The Receiver is now ready to be reprogrammed.

7. RECEIVER: SPECIFICATIONS & CONTROLS

Power: 12-24 VAC/DC nominal (11-30 V max); 100 mA max current draw. Power may be supplied from the operator or alternatively from an external supply.

Dimensions: 4.12”L x 3.65”W x 1.65”H

7. RECEIVER: SPECIFICATIONS & CONTROLS (cont.)

Cable Connections: Screw clamp type terminal blocks for 18-26 AWG wire

Operator Wiring: Screw clamp type terminal blocks for 18-26 AWG wire

External Antenna: F-connector coax extender for antenna

Program Button: Used to associate a Transmitter with the desired receiver channel

Check Button: Used to determine signal strength

RX Indicator Lights:

- Check LED:
 1. Blinks every ~5 seconds to indicate working properly if both channels are programmed
 2. After **check** button is pressed, blinks to indicate signal strength; 4 or 5 blinks is ideal
- R1 and R2 LEDs:
 1. Off when the associated edge is **learned** and has no faults
 2. On solid: No Transmitters **learned** or edge activated
- R3 LED: **On** when low battery relay is active
- A TEST LED: **On** when in **test** mode

Connections:

- Power (2): Positive and ground, or AC
- Relay Output 1:
 1. CS1: Normally Closed
 2. C1: Common
 3. BS1: 10K termination
- Relay Output 2:
 1. CS1: Normally Closed
 2. C1: Common
 3. BS1: 10K termination
- Relay Output 3 (2): Relay closes when low battery is detected
- A TEST (2): Connect to switched DC power (+ and Com) for Normally Closed monitoring

8. TRANSMITTER: SPECIFICATIONS & CONTROLS

Transmitter Frequency: 916 MHz, FSK modulation

Mounting: 4 corner screws (provided)

Power Source: Batteries: 2 AA, 3.6V lithium, 2 year life expectancy

Dimensions: 1.80”L x 4.78”W x 1.75”H

Program Button: Momentary push button is used to associate the Transmitter to the Receiver

TX Indicator Lights:

- Green LED: Normally off
- Press **program button** for status

9. FCC COMPLIANCE

Transmitter

Model: RB-TX10

FCC ID: U5Z-RB-TX10

Receiver

Model: RB-G-RX10

FCC ID: U5Z-RB-G-RX10

This device complies with Part 15 of the FCC rules. Operation is subject to the following two conditions:

1. This device may not cause harmful interference and
2. This device must accept any interference received, including interference that may cause undesired operation.

This equipment has been tested and found to comply with the limits for a Class B digital device, pursuant to Part 15 of the FCC Rules:

These limits are designed to provide reasonable protection against harmful interference in a residential installation. This equipment generates, uses and can radiate radio frequency energy and, if not installed and used in accordance with the instructions, may cause harmful interference to radio communications. However, there is no guarantee that interference will not occur in a particular installation. If this equipment does cause harmful interference to radio or television reception, which may be determined by turning the equipment off and on, the user is encouraged to try to correct the interference by one or more of the following measures:

1. Re-orient or relocate the receiver antenna
2. Increase the separation between the equipment and the receiver
3. Connect the equipment into an outlet on a circuit different from that to which the receiver is connected
4. Consult the dealer or an experienced radio/TV technician for help

Changes or modifications not expressly approved by the party responsible for compliance could void the user’s authority to operate the equipment.

**NORMALLY CLOSED ADDENDUM:
Removable Connector Assignments by Manufacturer**

All-O-Matic

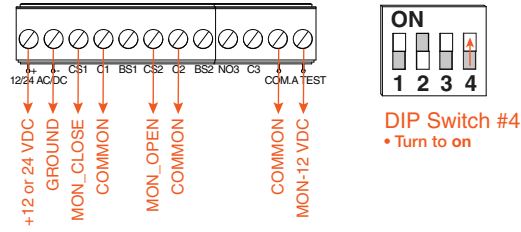

HySecurity

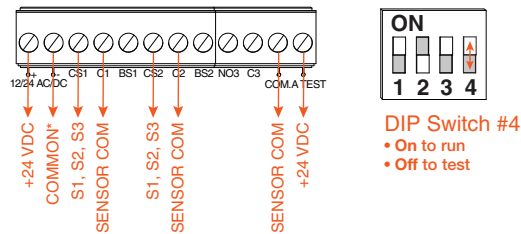

* Not "Sensor Common"

Maximum Controls

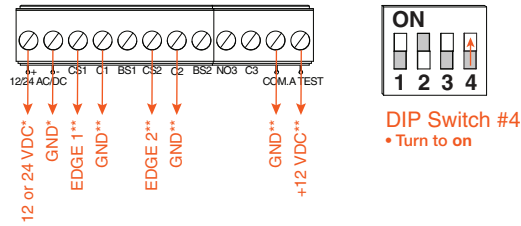

* Main board
 ** MC200 Motor Controller