

Art. RANGER

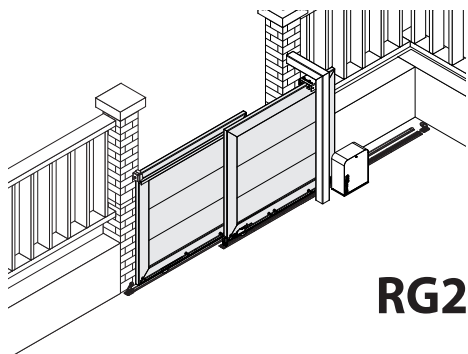

RG2

COMUNELLO
GATE DIVISION

UNI/EN ISO9001 - UNI/EN ISO14000

© 2019 - Fratelli Comunello Spa - All right reserved
Via Cassola, 64 - 36027 Rosà (VI) - Italy

04/21 Rev. 01

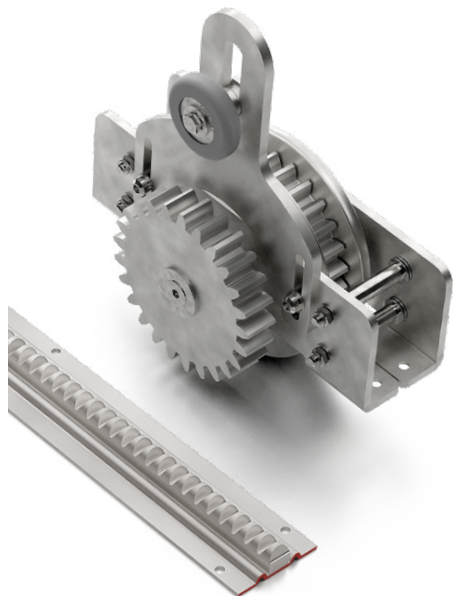

ITA

IMPIEGO: Kit per l'installazione di cancelli scorrevoli telescopici.
TIPO: Kit Ranger per cancelli telescopici.
MATERIALE: Acciaio Zincato.
RICICLO: Smaltire come materiale ferroso secondo le leggi del paese di installazione.
PARTI SOGGETTE AD USURA: Cuscinetti, ruote, ingranaggi, binario e cremagliera.
AVVERTENZE:
a) Obbligo dell'utilizzo dei battenti di fine corsa.
b) Per applicazioni dove la velocità è elevata, consigliamo di utilizzare il riduttore di velocità cod.RG40
c) Il costruttore si riserva di modificare senza preavviso le caratteristiche del prodotto secondo le proprie esigenze. Il costruttore non risponde di modifiche anche parziali del prodotto e le prestazioni dichiarate sono valide solo se si seguono le modalità di installazione eseguite da personale qualificato.

CADENZA MANUTENZIONI				
CASA PRIVATA	AZIENDA	MAGAZZINO	CONDOMINIO <20 UNITA' 6 MESI*	CONDOMINIO > 20 UNITA' 6 MESI*
2 ANNI*	2 ANNI*	1 ANNO*		
Verificare funzionalità e integrità delle ruote e cremagliera				
Verificare l'usura delle ruote, binari, ingranaggi e cremagliera				
Eseguire una manutenzione periodica per le cremagliere, ruote, ingranaggi e binari.				
*Lo schema riportato è relativo ad un ambiente di lavoro normale (non ambiente marino o aggressivo).				

DE

GEBRAUCH: Bausatz zum Einbau von Teleskopschiebetoren.
TYP: Ranger Bausatz für Teleskoptore.
MATERIAL: Verzinkter Stahl
Wiederverwendung: Als eisenhaltiges Material gemäß den Gesetzen des Installationslandes entsorgen.
Abnutzungspflichtigen Teilen: Lager, Räder, Zahnräder, Laufschiene und Zahnstange.
WICHTIGE HINWEISE:
a) Verpflichtung zur Verwendung von Torendpuffern.
b) Für Anwendungen mit hoher Geschwindigkeit empfehlen wir die Verwendung des Drehzahlminderers cod.RG40
c) Der Hersteller behält sich das Recht vor, die Produkteigenschaften nach seinem Dafürhalten ohne Vorankündigung zu ändern. Der Hersteller haftet nicht für die am Produkt durchgeführten Änderungen. Die angegebenen Leistungen haben nur dann Gültigkeit, wenn die Installation von qualifiziertem Fachpersonal ausgeführt worden ist.

WARTUNGSPLAN				
WOHNHAUS	FIRMA	LAGER	WOHNHAUS <20 WOHNUNGEN	WOHNHAUS > 20 WOHNUNGEN
2 JAHRE*	2 JAHRE*	1 JAHR*	6 MONATE*	6 MONATE*
Führen Sie regelmäßige Wartungsarbeiten an Zahnstangen, Rädern, Zahnrädern und Getrieben durch.				
Zahnrad- und Zahnstangenverschleiß prüfen				
Überprüfen Sie, ob die Befestigungsschrauben des Zahnstangen an der Einschienenbahn befestigt sind				
* Die Angaben beziehen sich auf einen Standort mit normaler Belastung (nicht in der Nähe von Salzwasser oder mit besonders aggressiven Bedingungen).				

FRA

UTILISATION: Kit pour l'installation de portes coulissantes télescopiques.
TYPE: Kit Ranger pour portes télescopiques.
MATÉRIEAU: Acier galvanisé.
RECYCLAGE: Eliminer comme matériau ferreux conformément aux lois du pays d'installation.
PIÈCES SOUMISES À L'USURE: roulements, roues, engranages, monorail and racks.
AVERTISSEMENT:
a) L'utilisation de butées mécaniques est strictement requise
b) Pour les applications où la vitesse doit être considérée comme élevée, nous vous recommandons d'utiliser le réducteur de vitesse (cod.RG40).
c) Le constructeur se réserve le droit de modifier sans préavis les caractéristiques du produit selon ses propres exigences. Le constructeur ne répond pas des modifications même partielles du produit et les performances déclarées ne sont valables que si l'on respecte les modalités d'installation effectuées par du personnel qualifié.

FREQUENCE ENTRETIENS				
MAISON PARTICULIER	ENTREPRISE	DEPOT	IMMEUBLE <20 UNITES	IMMEUBLE > 20 UNITES
2 ANS*	2 ANS*	1 AN*	6 MOIS*	6 MOIS*
Vérifier la fonctionnalité et l'intégrité de roues et crémaillère.				
Vérifier l'usage de roues, rails, engranages et crémaillère.				
Effectuer une maintenance périodique pour crémaillères, roues, engranages et rails				
* Le schéma se rapporte à un milieu de travail normal (pas un milieu marin ni particulièrement agressif).				

ESP

USO: Kit para la instalación de puertas correderas telescópicas.
TIPO: Kit Ranger para puertas telescópicas.
MATERIAL: Acero galvanizado.
RECICLAJE: Desechar como material ferroso según las leyes vigentes en el país de instalación.
PIEZAS SUJETAS A DESGASTE: Cuscinetti, ruote, ingranaggi, binario e cremagliera.
ADVERTENCIAS:
a) El uso de topes mecánicos es estrictamente requerido.
b) Para aplicaciones donde la velocidad debe considerarse alta, recomendamos utilizar el reductor de velocidad (cod.RG40).
c) El fabricante se reserva el derecho de cambiar las características del producto de acuerdo con sus necesidades sin previo aviso. El fabricante no es responsable de las modificaciones parciales del producto y los rendimientos declarados son válidos solo si se siguen los métodos de instalación indicados en las instrucciones y realizados por personal calificado.

CADENCIA MANTENIMIENTOS				
CASA PARTICULAR	EMPRESA	ALMACÉN	INMUEBLE EN CONDOMINIO <20 UNIDADES	INMUEBLE EN CONDOMINIO > 20 UNIDADES
2 AÑOS*	2 AÑOS*	1 AÑO*	6 MESES*	6 MESES*
Verificar funcionalidad e integridad de ruedas y cremalleras				
Controlar el desgaste de las ruedas, rieles, engranajes y cremallera.				
Realice un mantenimiento periódico de cremalleras, ruedas, engranajes y monorrails				
*El presente esquema es relativo a un ambiente normal de trabajo (no ambiente marino o agresivo).				

EN











USE: Kit for the installation of telescopic sliding gates.
TYPE: Ranger Kit for telescopic gates.
MATERIAL: Galvanized steel
RECYCLING: Dispose of as ferrous material in accordance with the laws of the country of installation.
PARTS SUBJECT TO WEAR: Bearings wheels, gears, monorails and racks.
WARNINGS:
a) The use of mechanical end-stops is strictly required.
b) For applications where the speed is to be considered high, we recommend using the speed reducer (cod.RG40).
c) The manufacturer reserves the right to change the characteristics of the product according to their needs without prior notice. The manufacturer is not liable for even partial modifications of the product and the declared performances are valid only if the installation methods indicated in the instructions and performed by qualified personnel are followed.

MAINTENANCE FREQUENCY				
PRIVATE HOME	BUSINESS	WAREHOUSE	CONDOMINIUM <20 UNITS	CONDOMINIUM > 20 UNITS
2 YEAR*	2 YEAR*	1 YEAR*	6 MONTHS*	6 MONTHS*
Check the functionality and integrity of wheels.				
Check for wear of wheels, bearings, monorails, gears and racks.				
Carry out a periodic maintenance of racks, wheels, gears and monorails.				
*The scheme refers to a normal workplace (not marine or particularly aggressive environments).				

RUS

ИСПОЛЬЗОВАНИЕ: Комплект для установки раздвижных телескопических ворот.
ТИП: Комплект Ranger для телескопических ворот.
МАТЕРИАЛ: Оцинкованная сталь.
ПЕРЕРАБОТКА: Утилизировать как железный материал в соответствии с действующим законодательством страны установки.
ДЕТАЛИ, ПРЕДМЕТНЫЕ ДЛЯ ИЗНОСА: Подшипники, колеса, шестерни, рельс, зубчатая рейка
ПРЕДУПРЕЖДЕНИЯ:
a) Обязательство использовать стопоры
b) Для приложений с высокой скоростью мы рекомендуем использовать редуктор скорости сг.RG40
c) Производитель оставляет за собой право изменять характеристики продукта в соответствии с его потребностями без предварительного уведомления. Производитель не несет ответственности даже за частичные модификации продукта, и заявленные характеристики действительны только при соблюдении методов установки, указанных в инструкциях и выполненных квалифицированным персоналом.

ПЕРИОДИЧНОСТЬ ТЕХОБСЛУЖИВАНИЯ				
ЧАСТНЫЙ ДОМ	ПРЕДПРИЯТИЕ	СКЛАД	ЖИЛОЙ ДОМ 20 КВАРТИР	ЖИЛОЙ ДОМ 20 КВАРТИР
2 ГОДА*	2 ГОДА*	1 ГОД*	6 МЕСЯЦЕВ*	6 МЕСЯЦЕВ*
Проверьте работоспособность и целостность зубчатой рейки				
Проверьте износ колесов, шестерни, рельса у зубчатой рейки				
Проводите периодическое техническое обслуживание на зубчатых рейках, колесах, шестернях и рельсов.				
*Параметры данной таблицы предусмотрены для нормального рабочего помещения (не для объектов вблизи моря или с другими агрессивными факторами).				

CODE CODICE	ART.	DESCRIPTION DESCRIZIONE	Tubular frame width Larghezza tubolare	Minimum tube height H minima tubolare	Max leaf weight Peso massimo anta kg	KIT ELEMENTS / Composizione kit			Kit per pack	Kg
						Drive wheel Ruota motrice	Free wheel Ruota condotta	Standard wheel with half-rounded groove Ruota standard gola semitonda		
* USA Item 11500440 001	RG2-100.50	Kit Ranger for telescopic door with 2 leaves, ø100 mm wheels for 50 mm tubular <i>Kit Ranger per cancello telescopico a due ante, ruote ø 100 mm per tubolare da 50 mm</i> <i>Kit Ranger pour porte télescopique avec deux vantaux, galets ø 100 mm pour tubulaire de 50 mm</i> <i>Kit Ranger für teleskopisches Schiebetores mit 2 Flügeln, ø100 mm Rädern für 50 mm Schlauchreifen</i> <i>Kit Ranger para puerta telescópica con dos hojas, ruedas de ø 100 mm para tubular de 50 mm</i> <i>Комплект Ranger для телескопических ворот с двумя створками, ø100 мм колеса для трубы 50 мм</i>	50 	80 	250	 Ø 107	 Ø 107	 Ø 117	1	10.3
11500408 001	RG2-140.100	Kit Ranger for telescopic door with 2 leaves, ø140 mm wheels for 100 mm tubular <i>Kit Ranger per cancello telescopico a due ante, ruote ø 140 mm per tubolare da 100 mm</i> <i>Kit Ranger pour porte télescopique avec deux vantaux, galets ø 140 mm pour tubulaire de 100 mm</i> <i>Kit Ranger für teleskopisches Schiebetores mit 2 Flügeln, ø140 mm Rädern für 100 mm Schlauchreifen</i> <i>Kit Ranger para puerta telescópica con dos hojas, ruedas ø 140 mm para tubular de 100 mm</i> <i>Комплект Ranger для телескопических ворот с двумя створками, ø140 мм колеса для трубы 100 мм</i>	100 	120 	400	 Ø 147	 Ø 147	 Ø 157	1	26.7

* The RG2-100.50 is the only Ranger hardware stocked in the USA. It fits 2x4 or 2x4 rectangular tubing.

*** The RG2-140.100 fits 4x5 or 4x6 rectangular tubing and is available by SPECIAL ORDER from Italy.

Z2

Z1

C

C

A

B

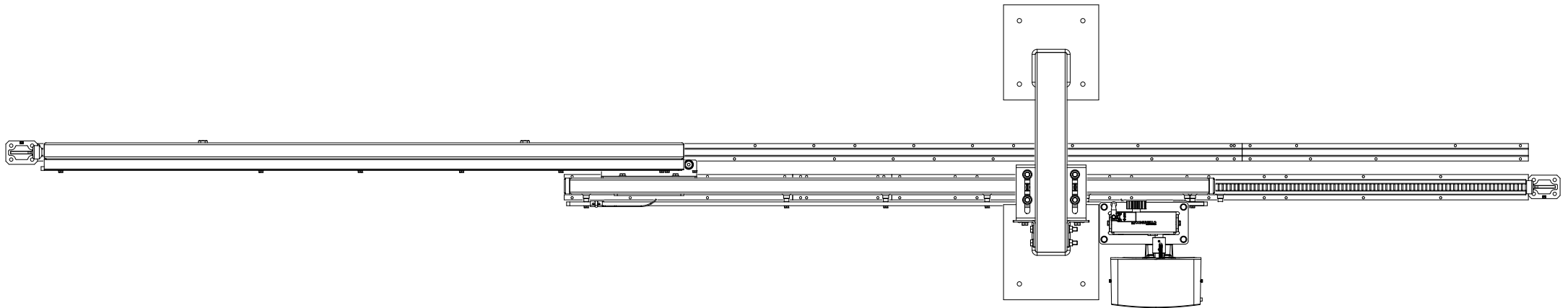
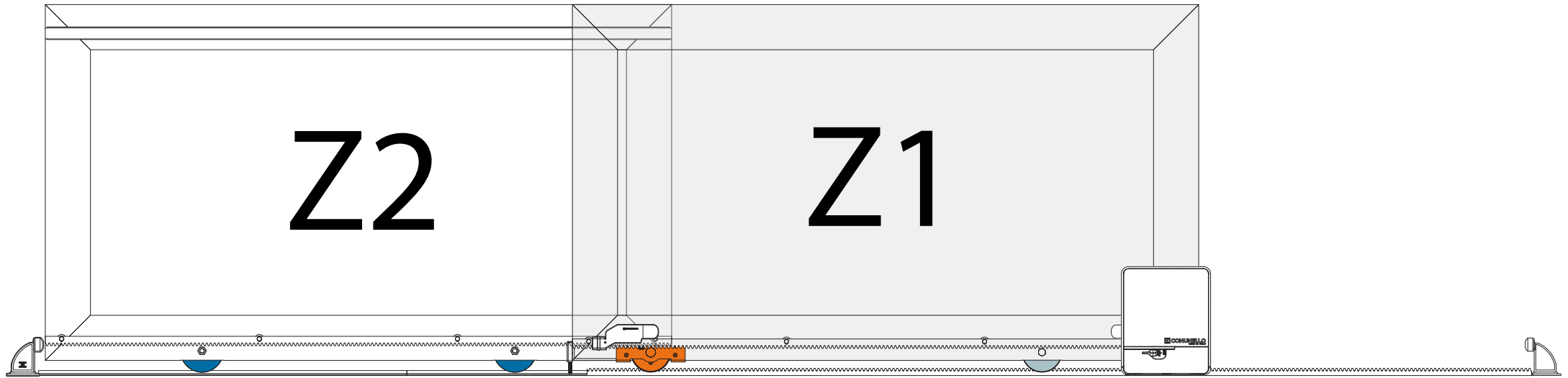

A
Principle
Drive Wheel

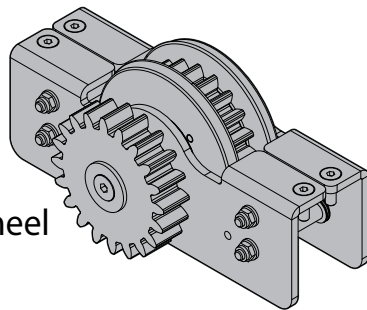

B
Free Wheel
or
Follower Wheel

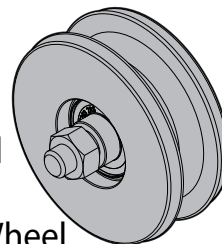

C
Standard
Wheel

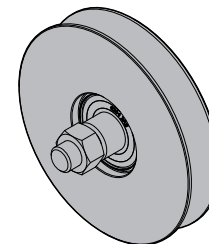

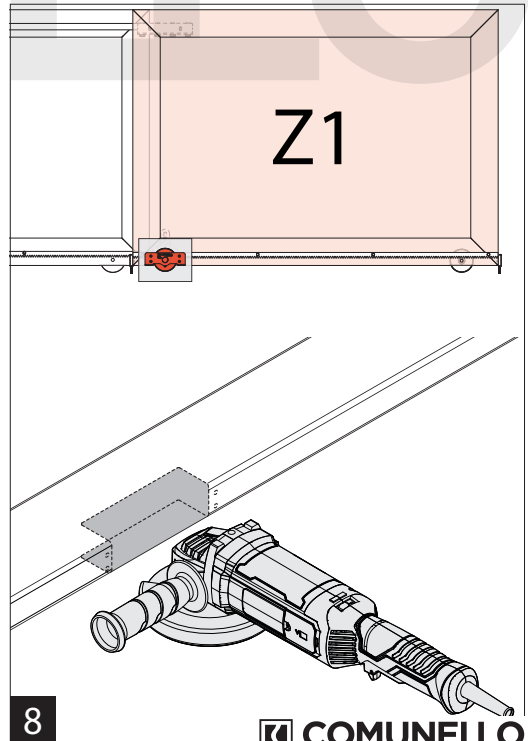
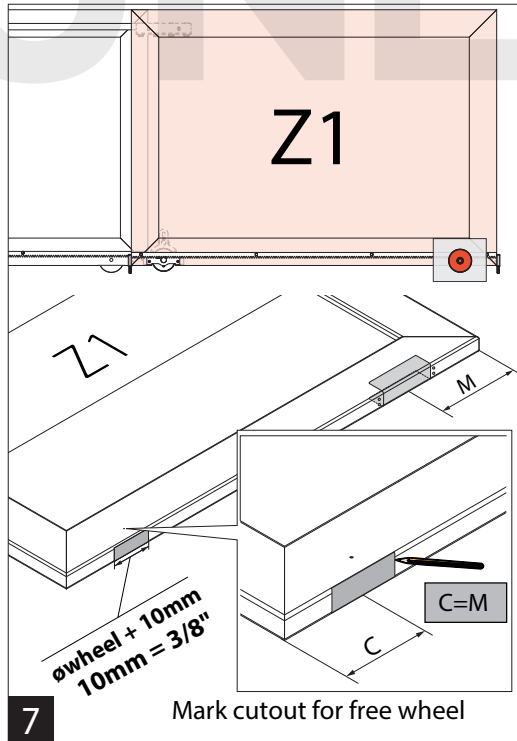
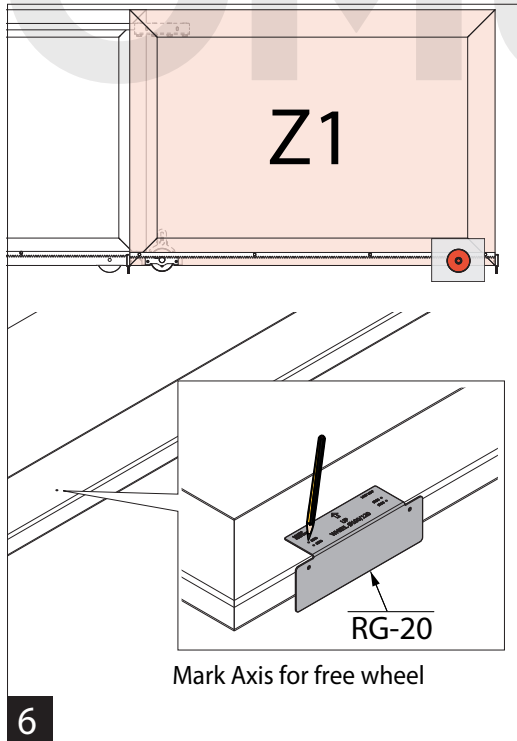
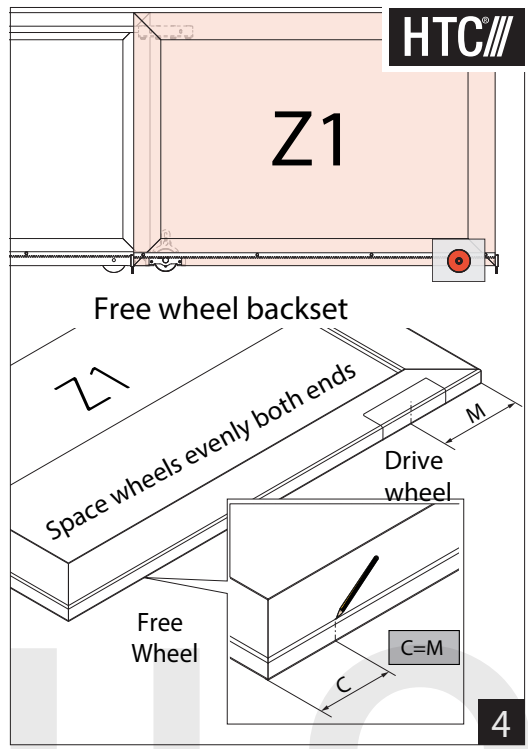
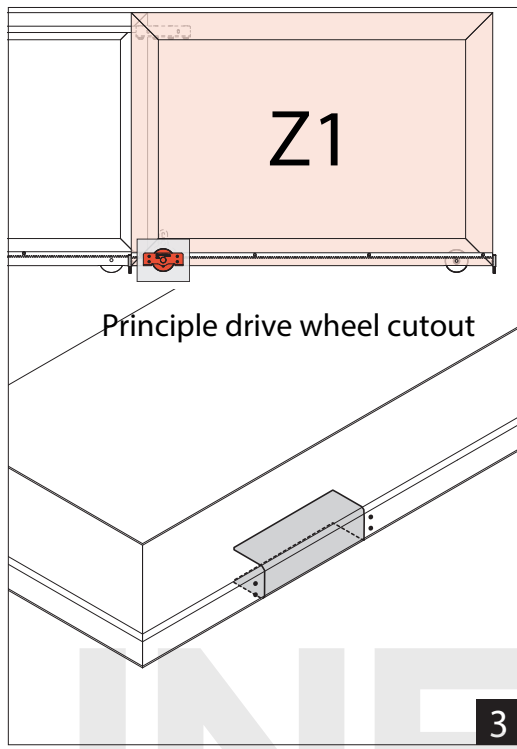
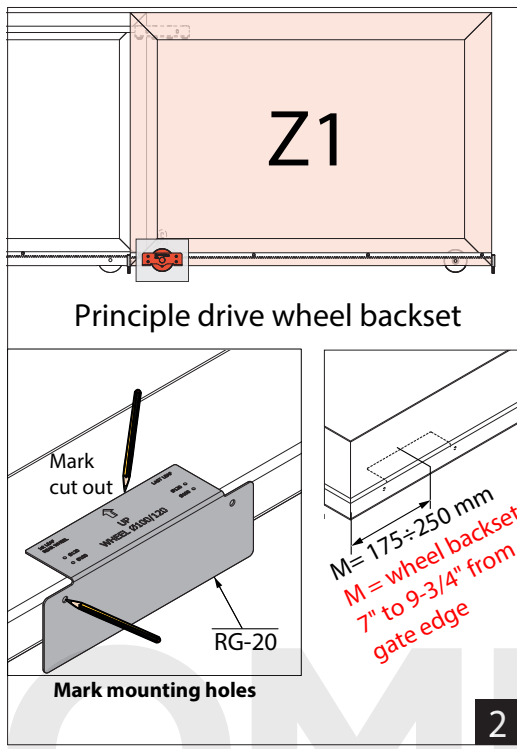
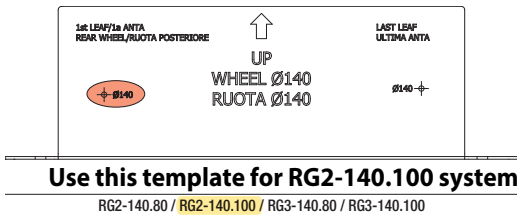
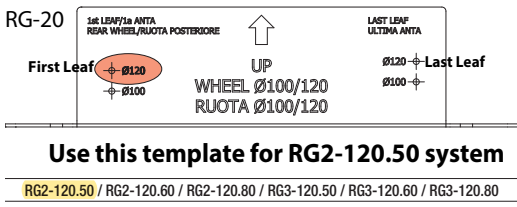
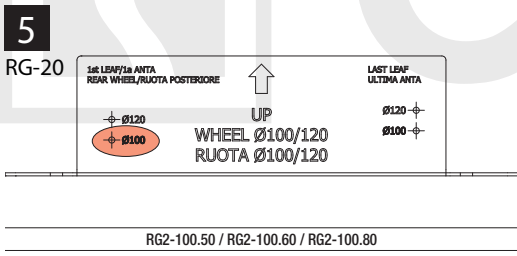
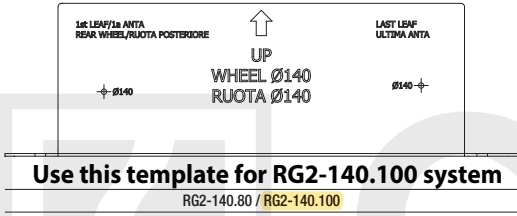
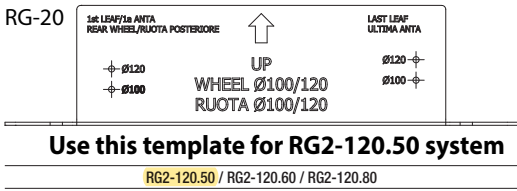
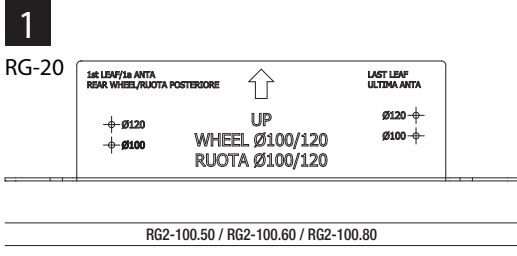

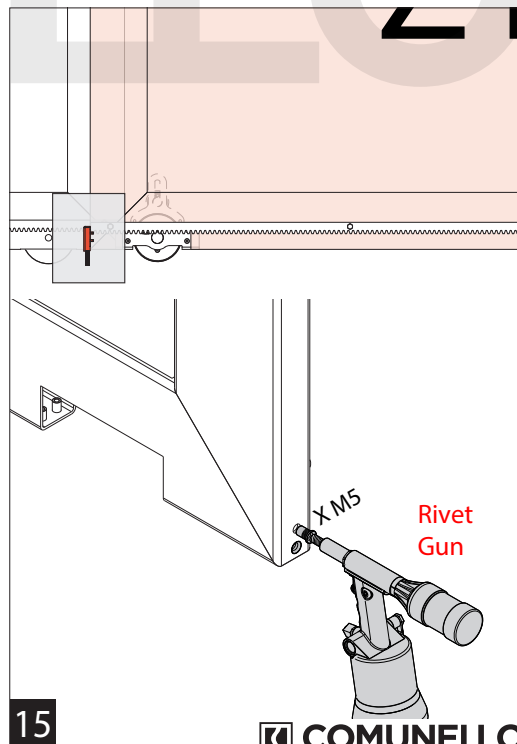
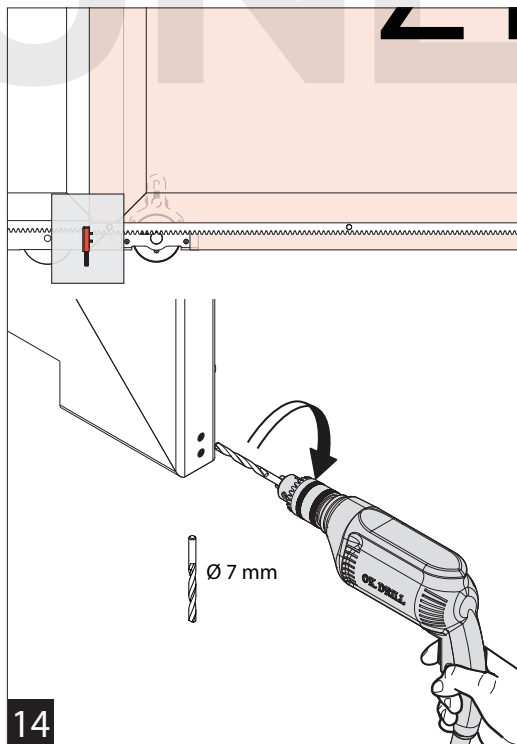
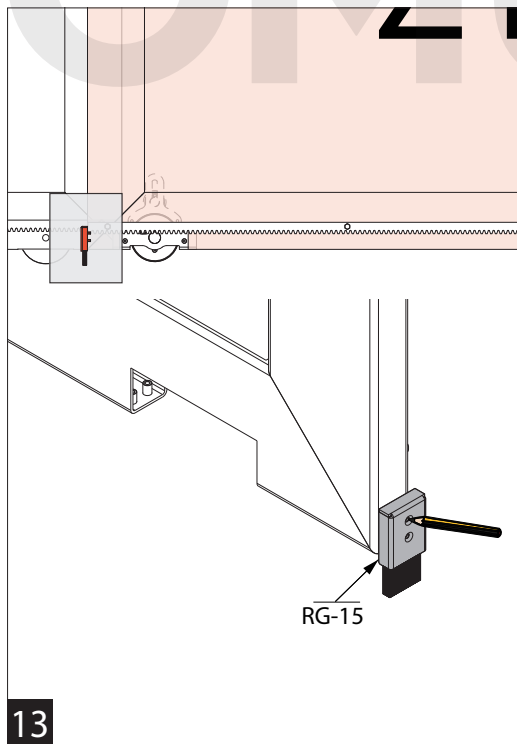
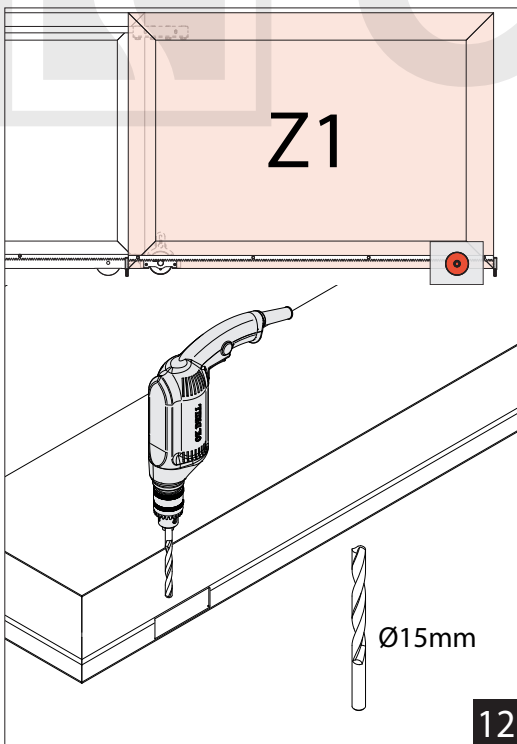
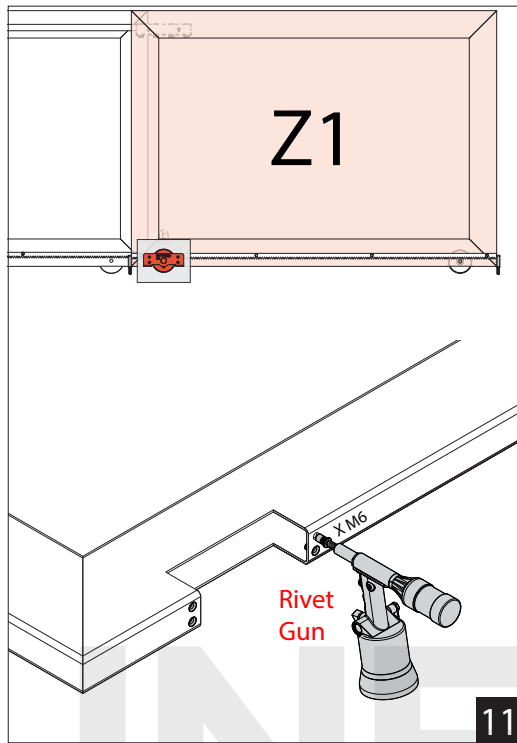
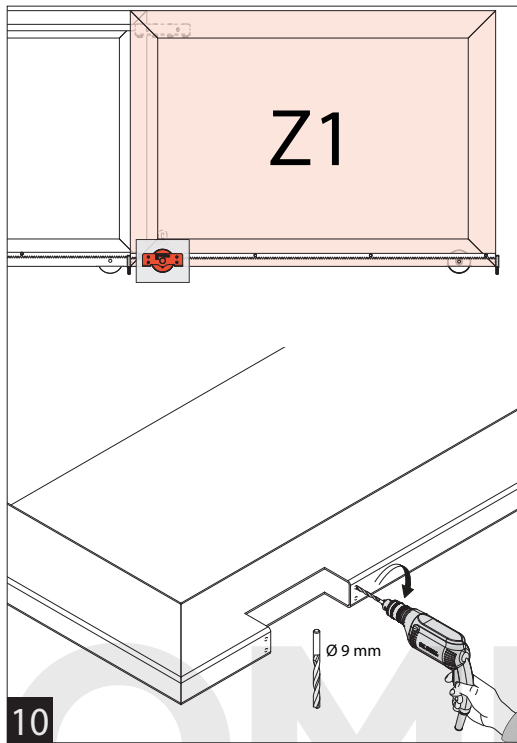
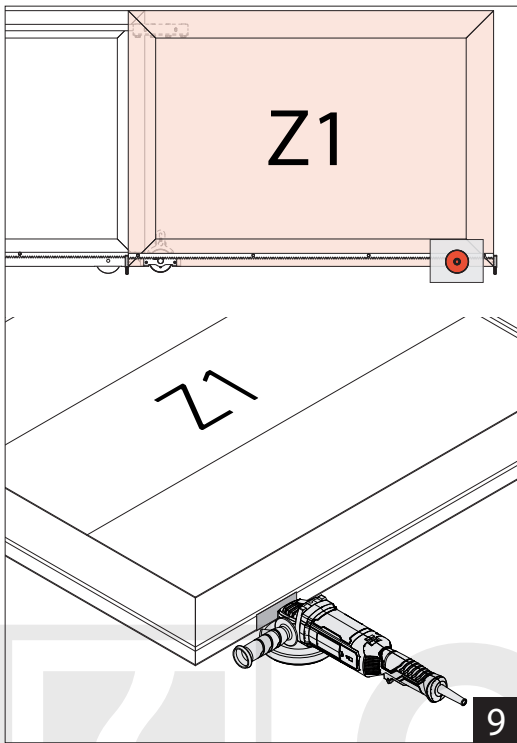

CODE ARTICLE	IMAGE	HOLE	TYPE
RG2-100.50		M14	2 LEAVES
RG2-100.60		M14	2 LEAVES
RG2-100.80		M14	2 LEAVES
RG2-120.50		M16	2 LEAVES
RG2-120.60		M14	2 LEAVES
RG2-120.80		M14	2 LEAVES
RG2-140.80		M16	2 LEAVES
RG2-140.100		M16	2 LEAVES

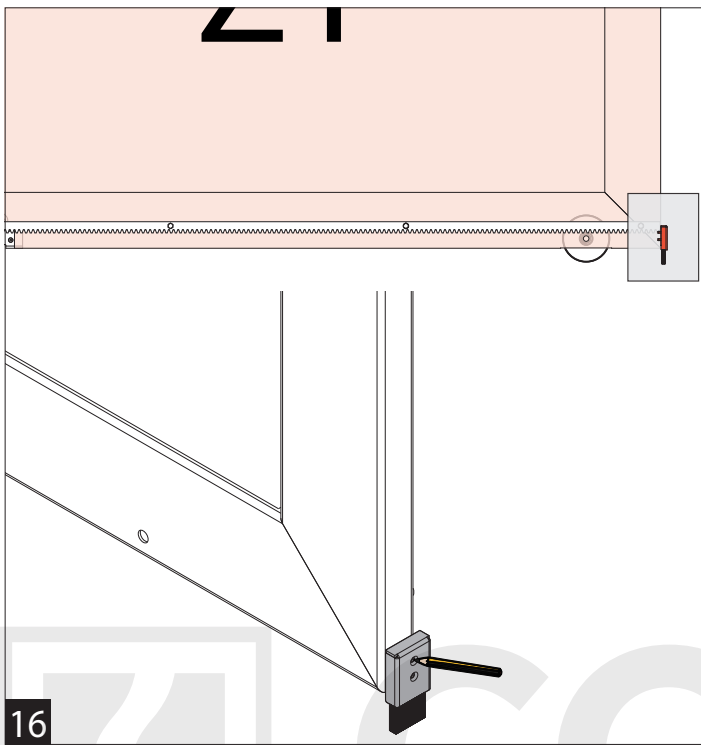

16

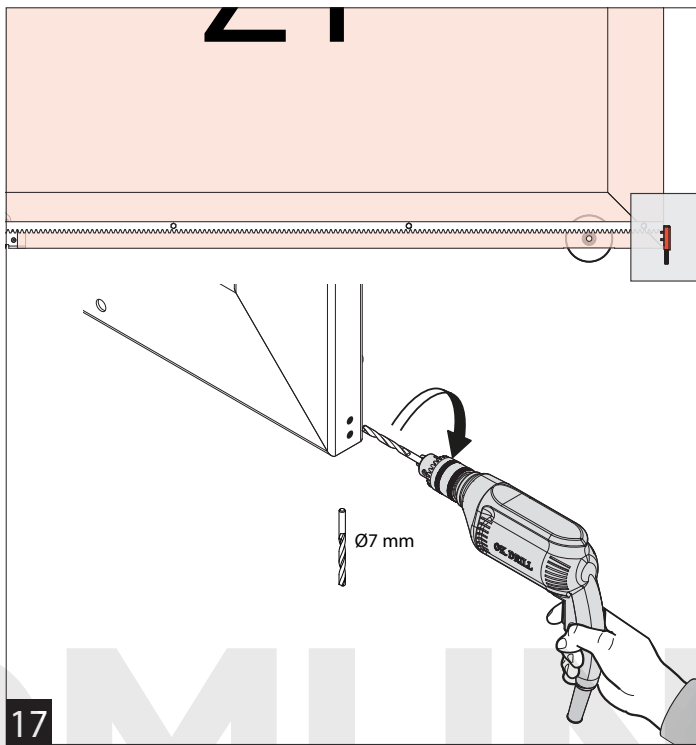

17

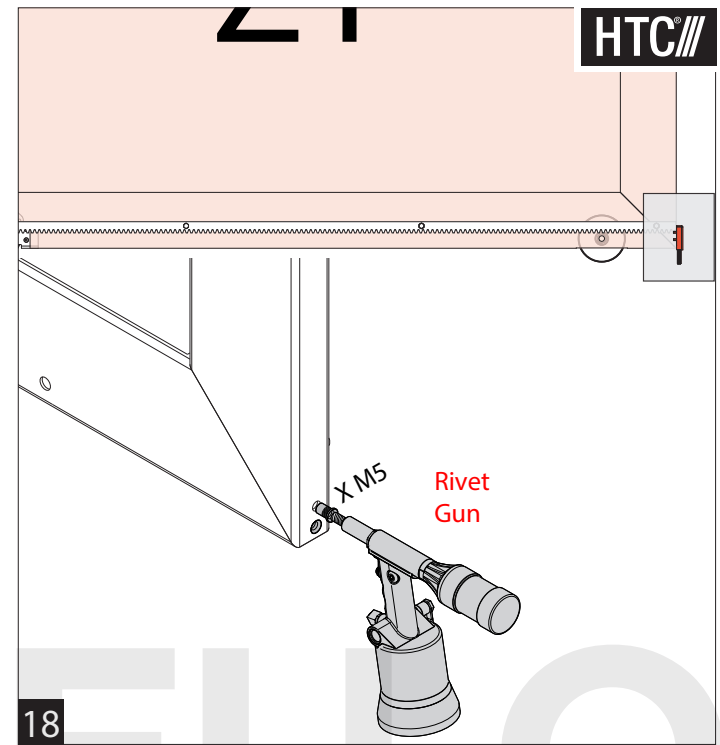

18

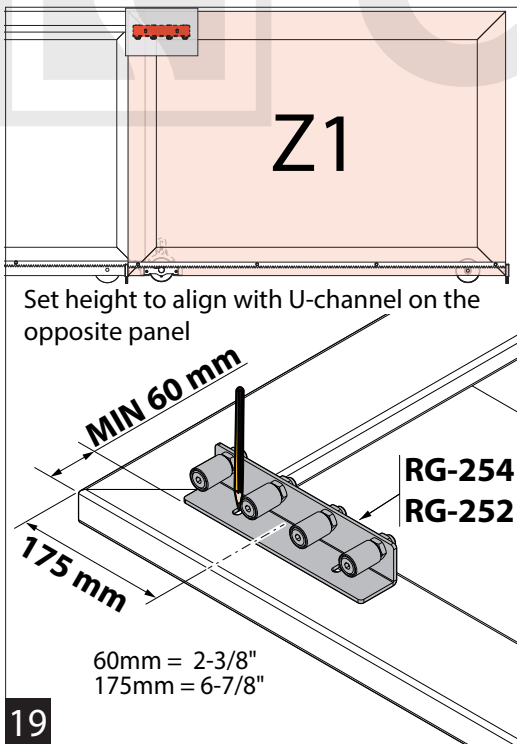

19

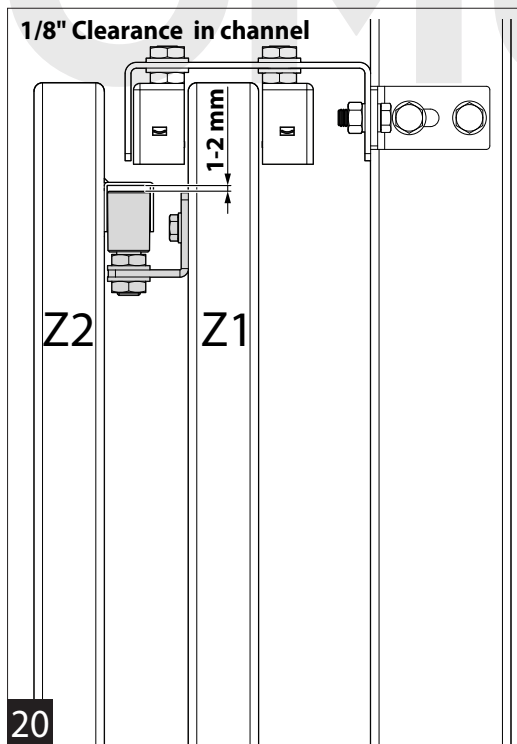

20

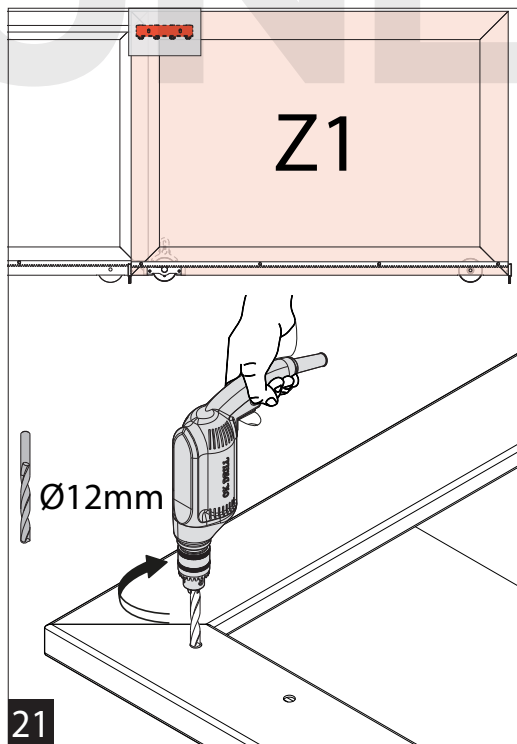

21

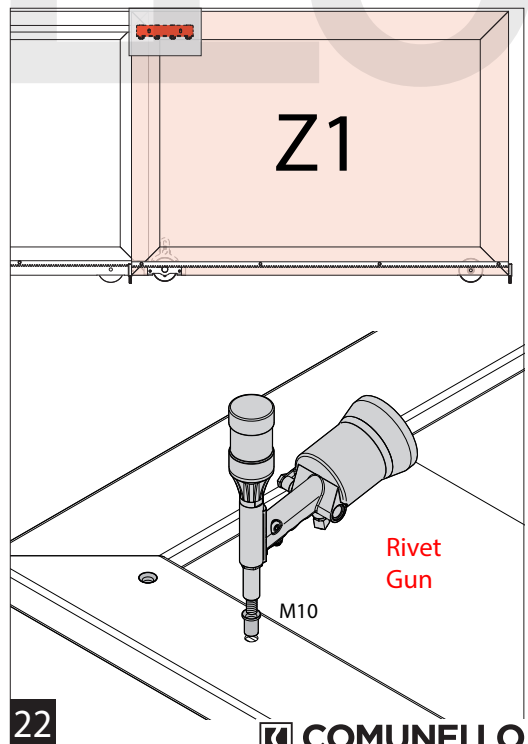

22

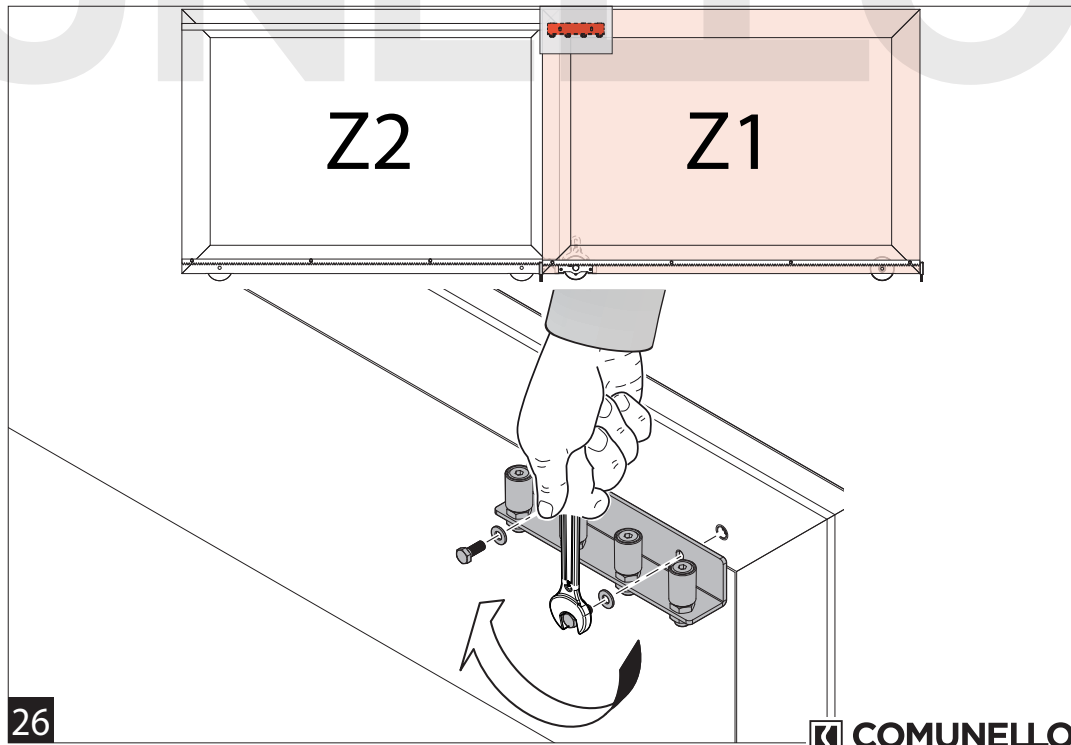
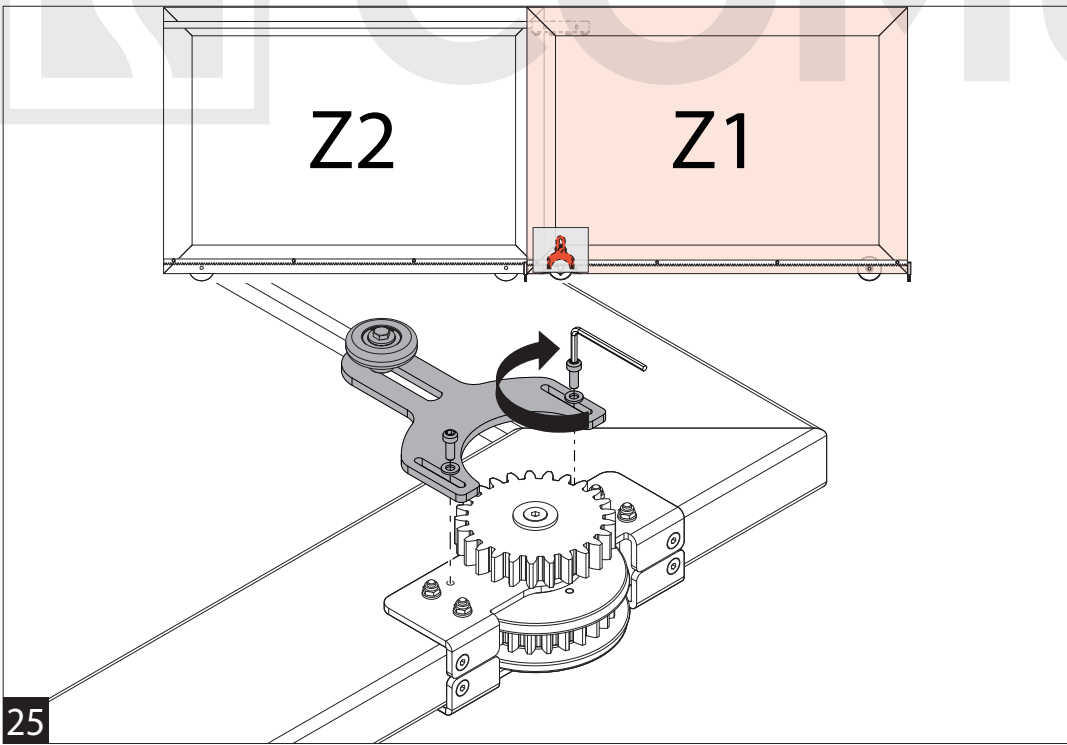
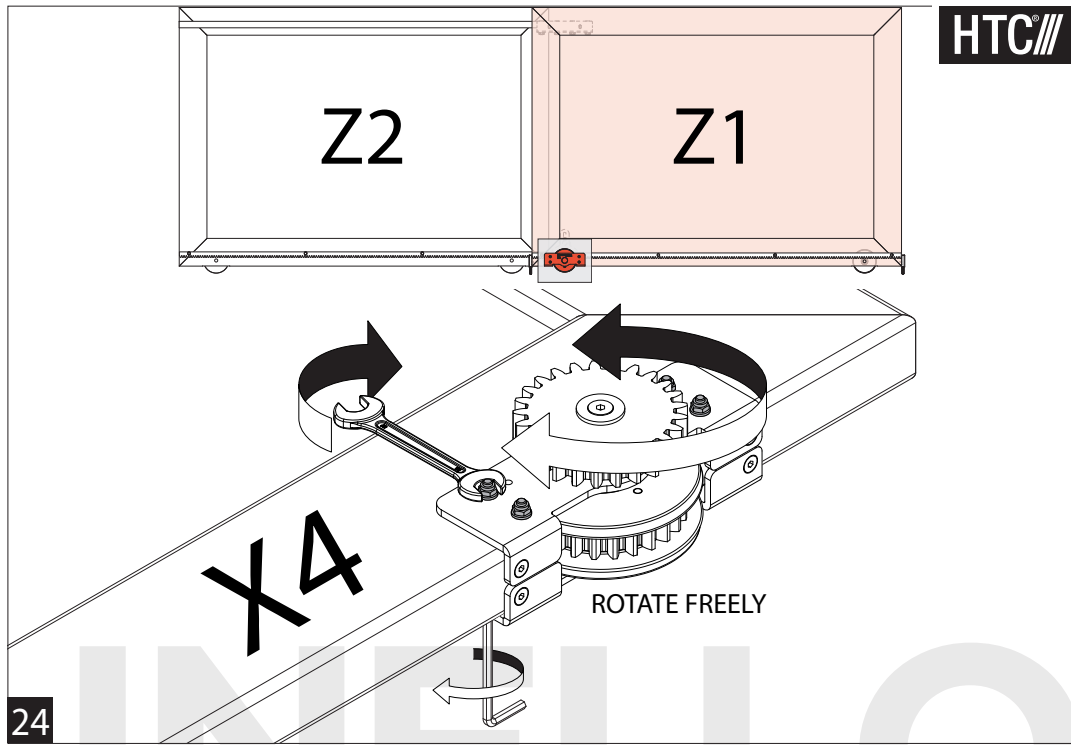
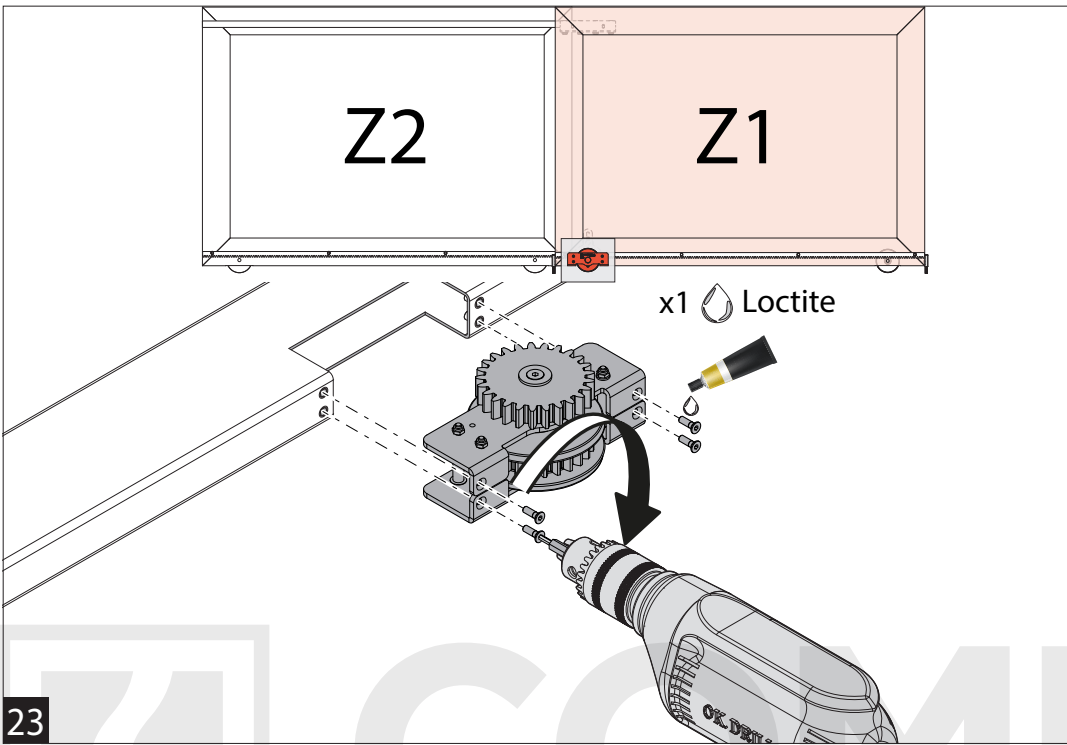

Z2

Z1

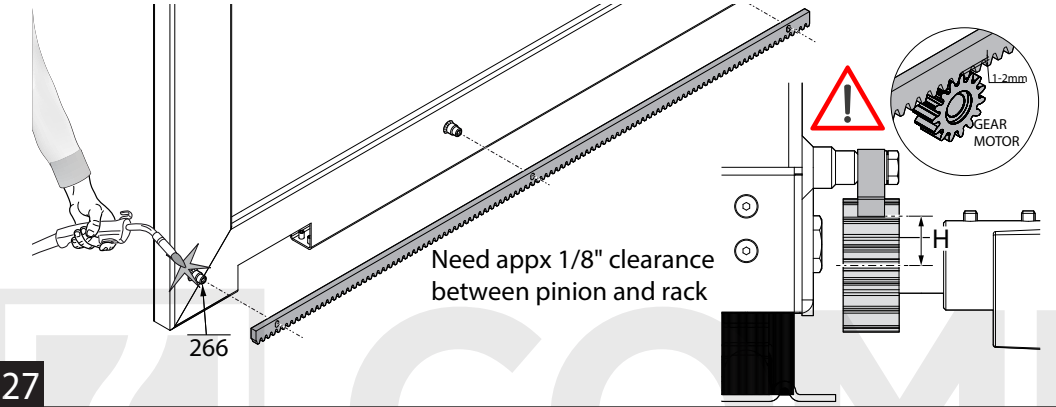

27

Z2

Z1

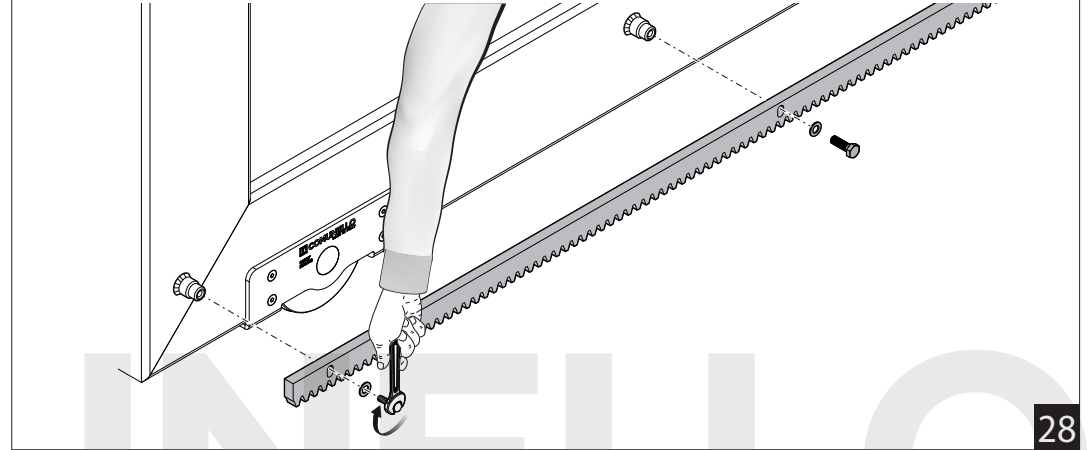

28

Z2

Z1

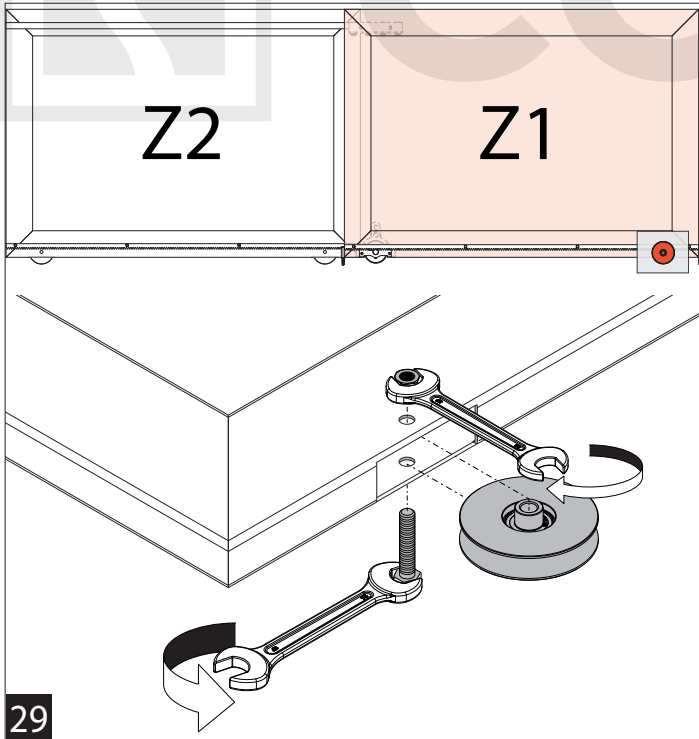

29

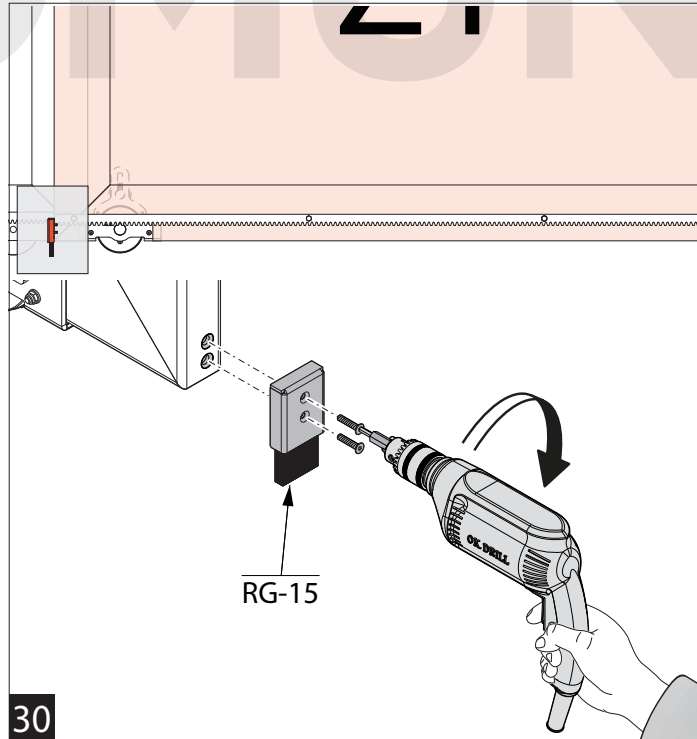

30

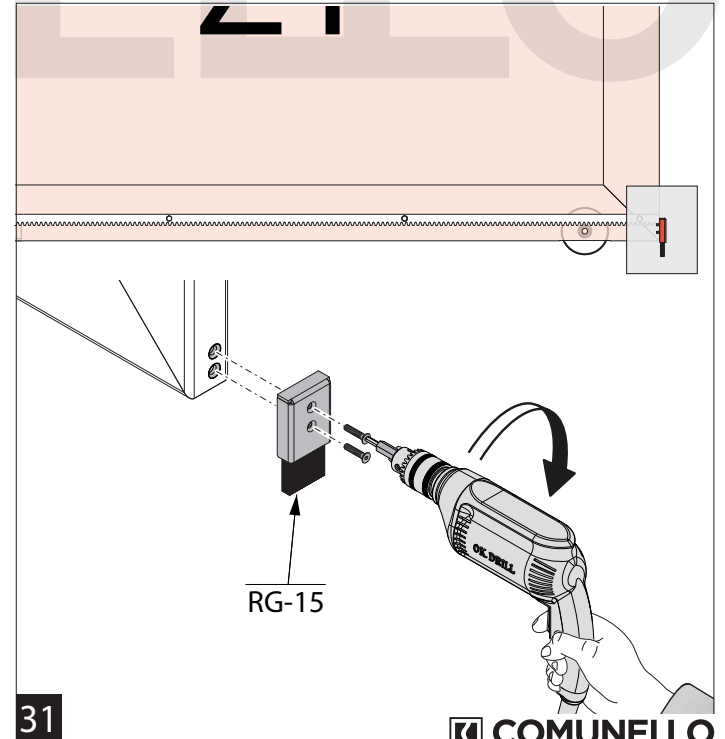

31

32

RG-20

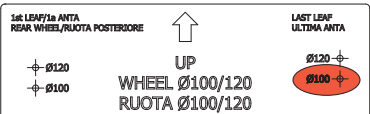

RG2-100.50 / RG2-100.60 / RG2-100.80

RG-20

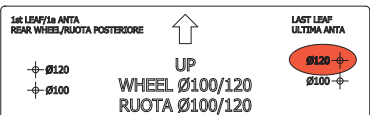

Use this template for RG2-120.50 system

RG2-120.50 / RG2-120.60 / RG2-120.80

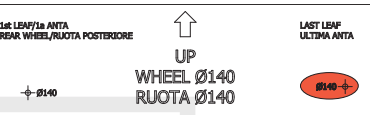

Use this template for RG2-140.100 system

RG2-140.80 / RG2-140.100

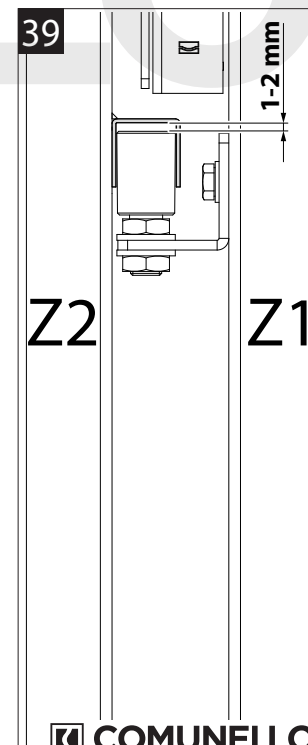
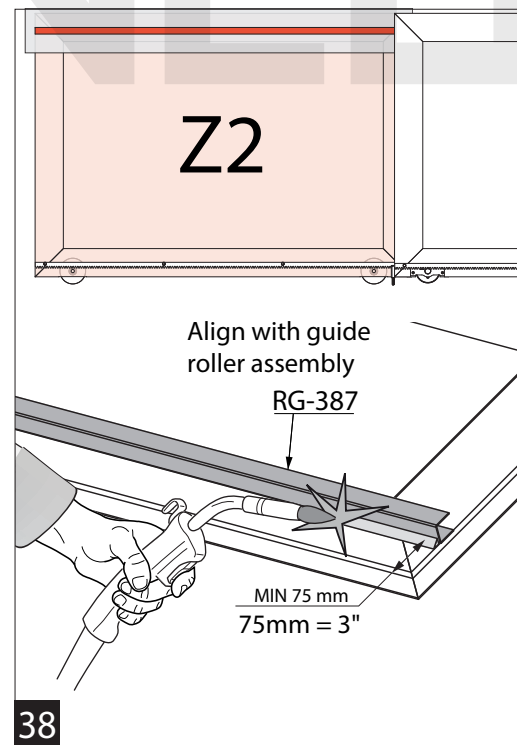
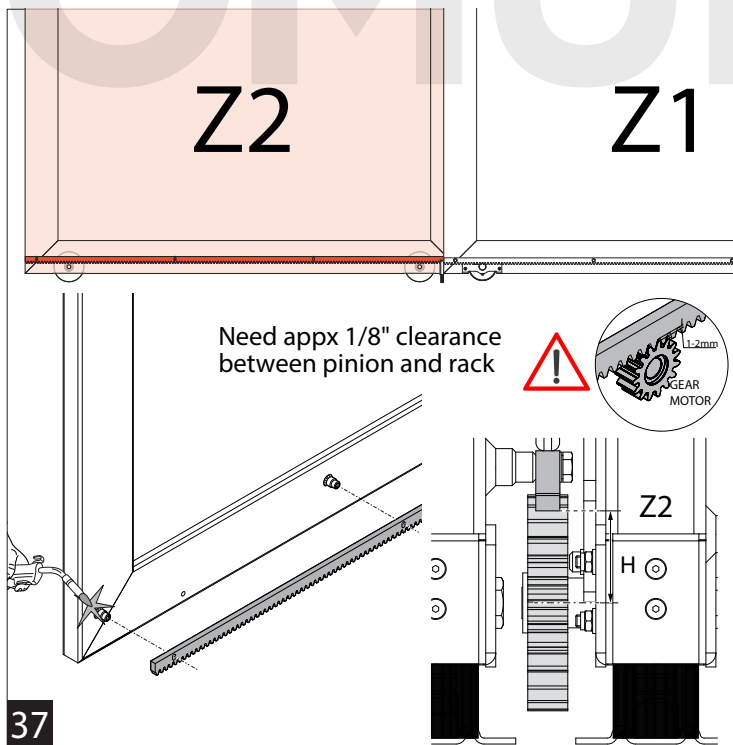
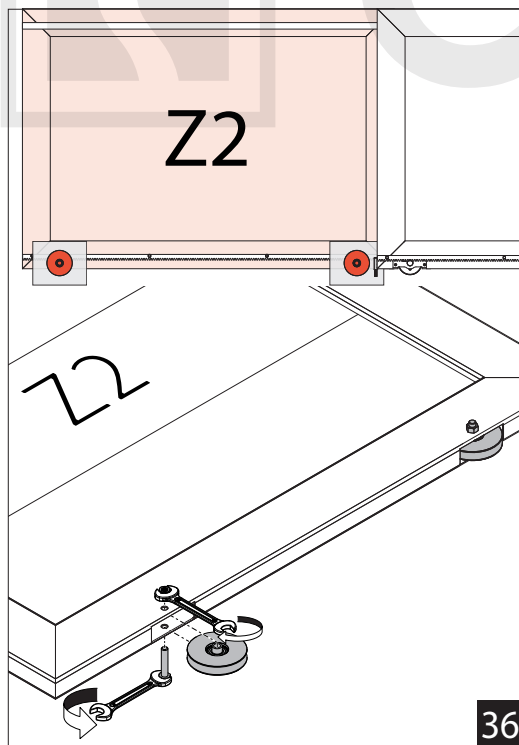
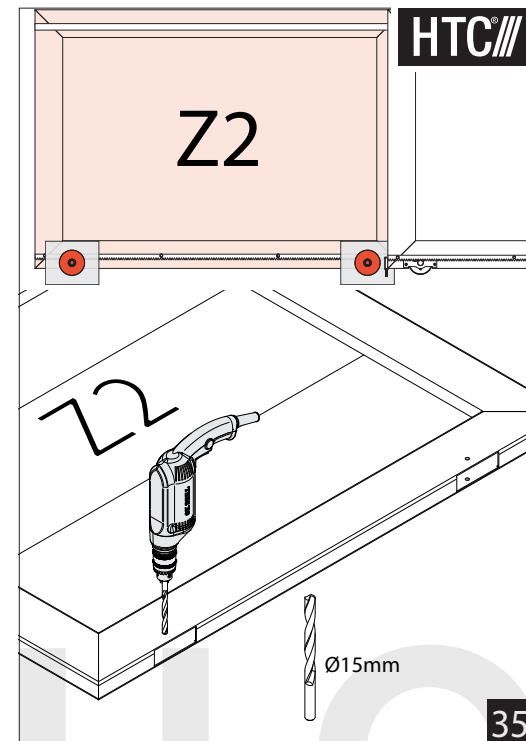
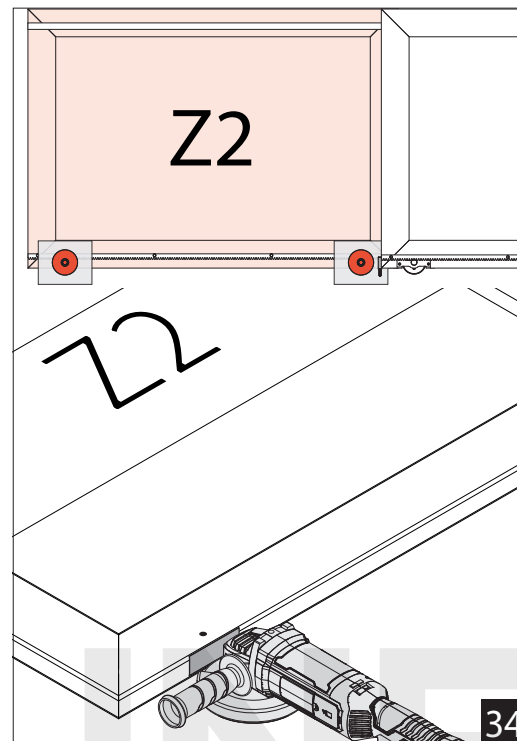
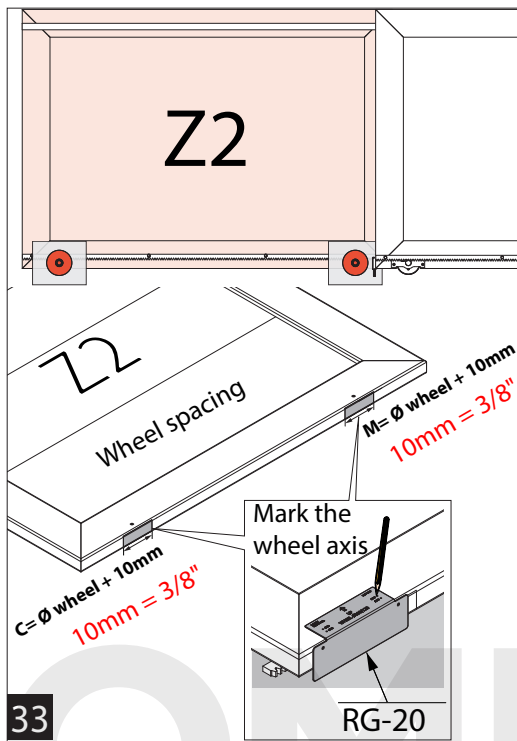

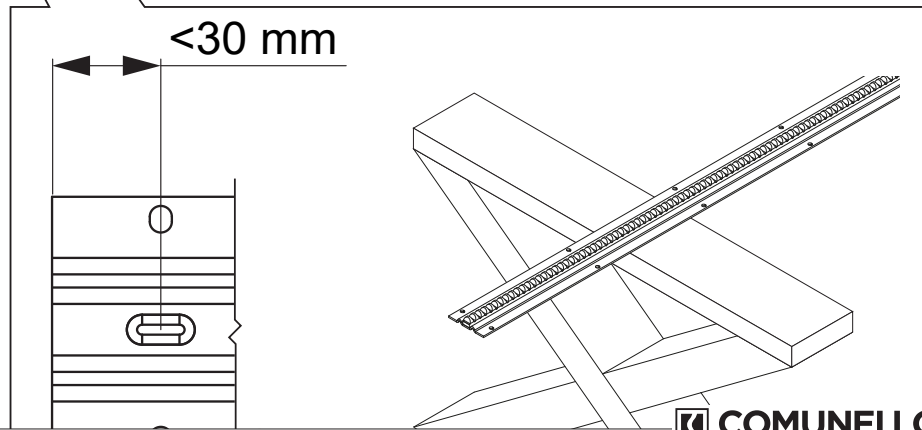
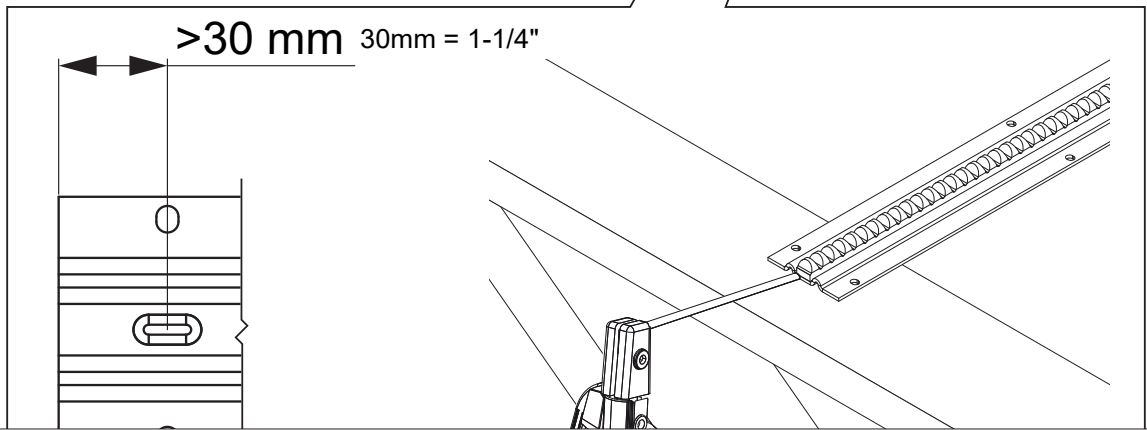
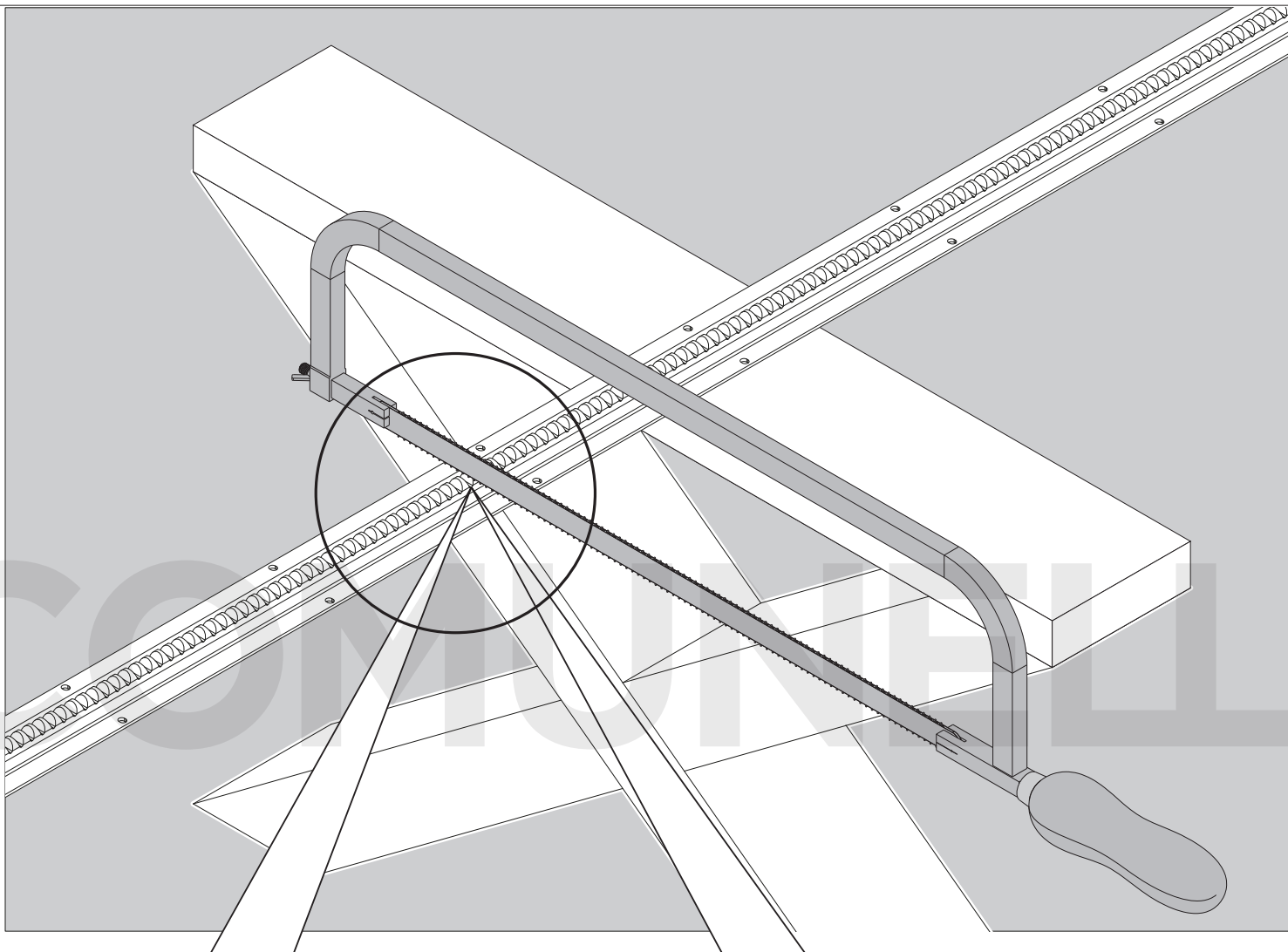

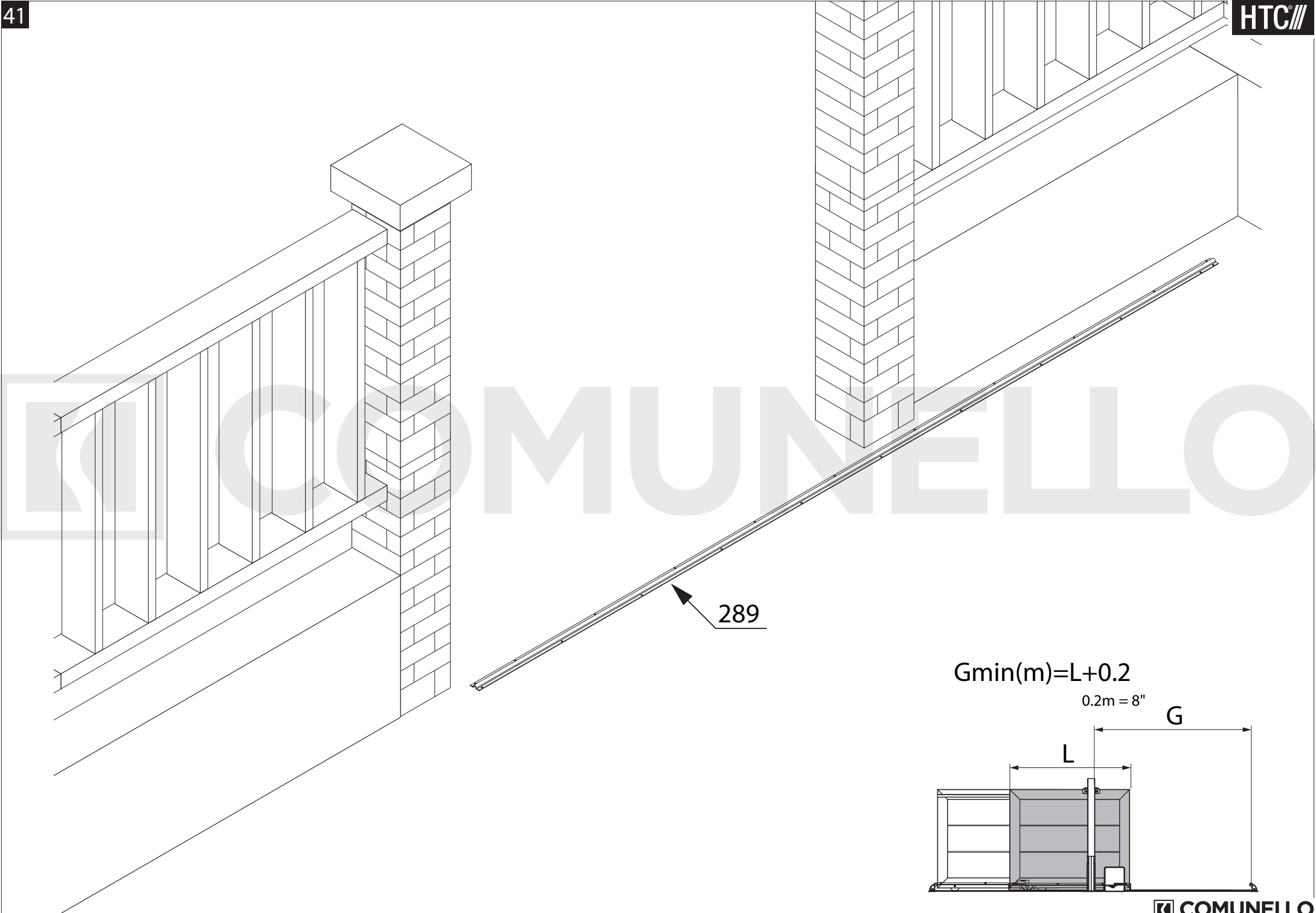

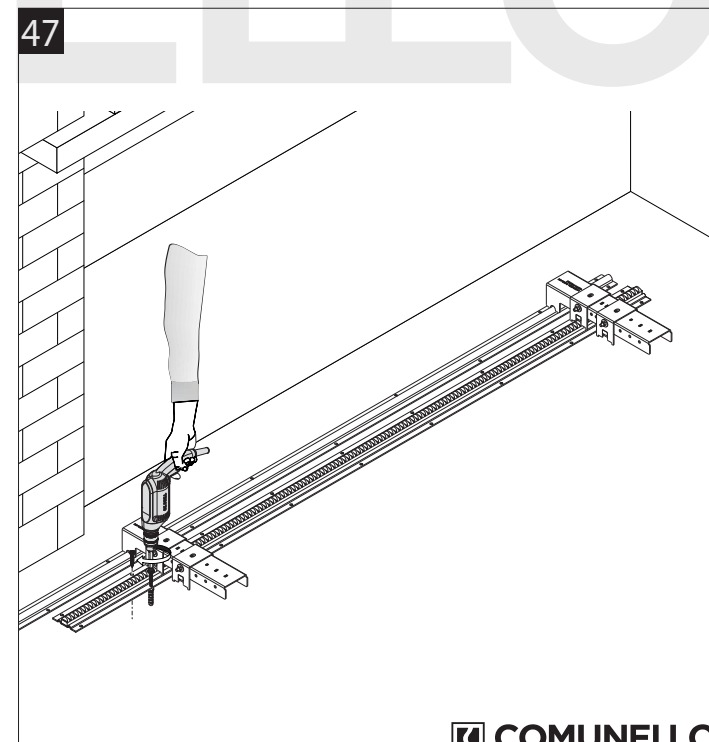
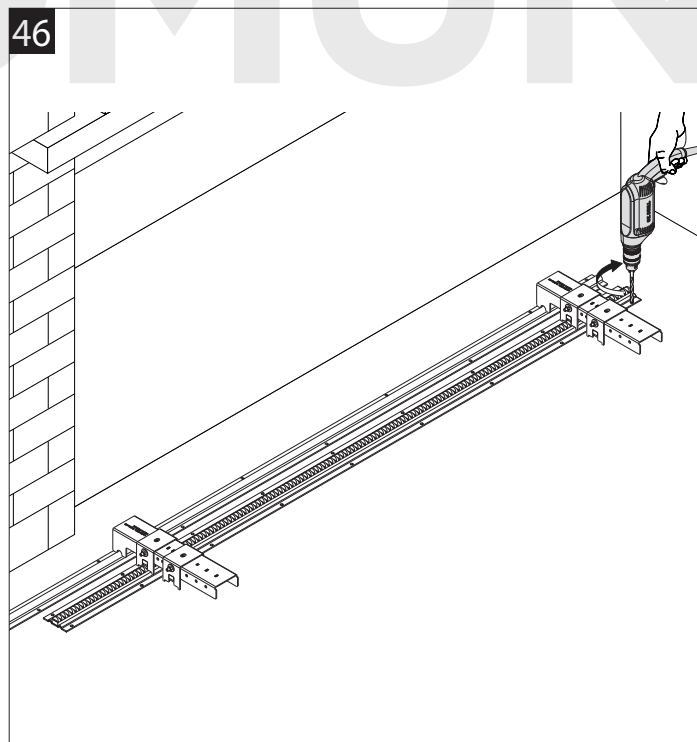
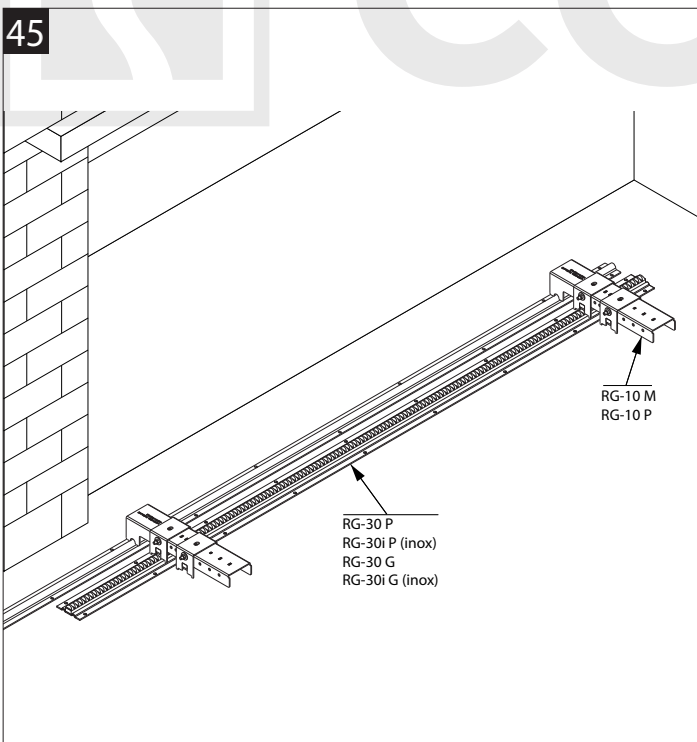
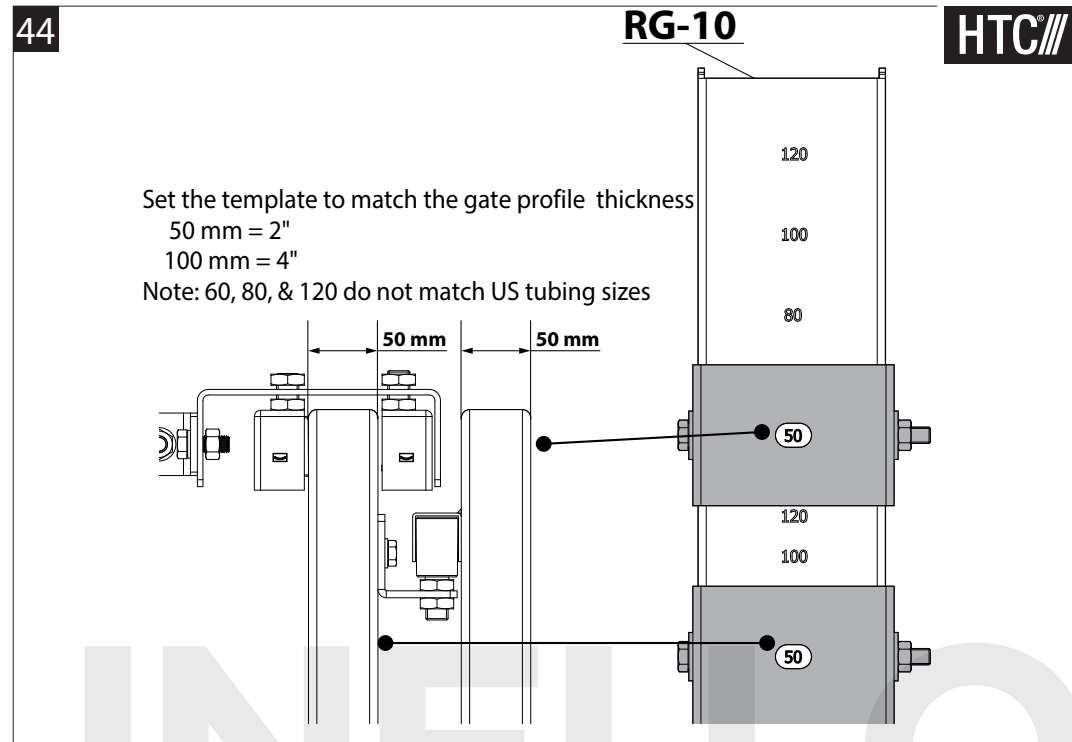
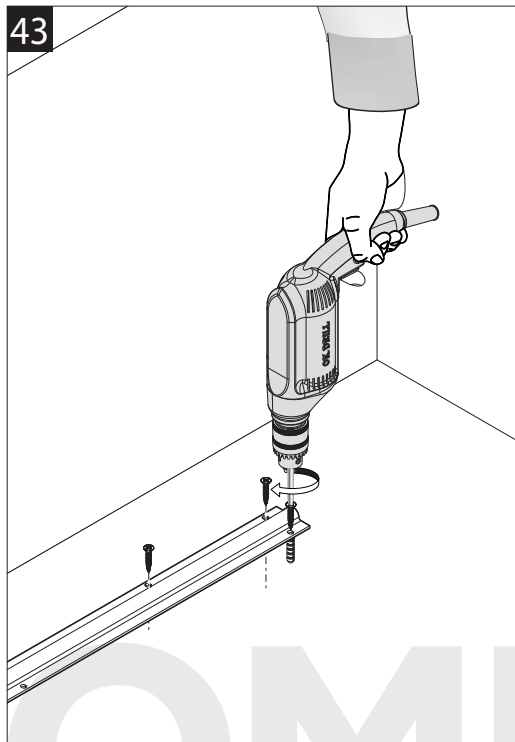
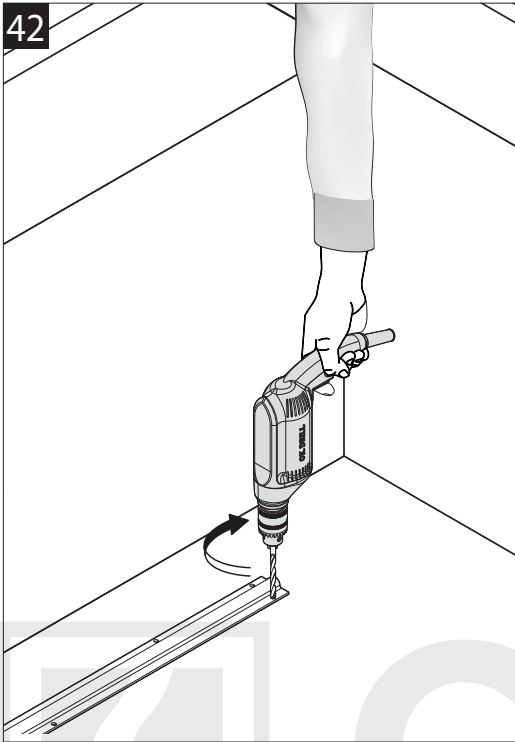

48

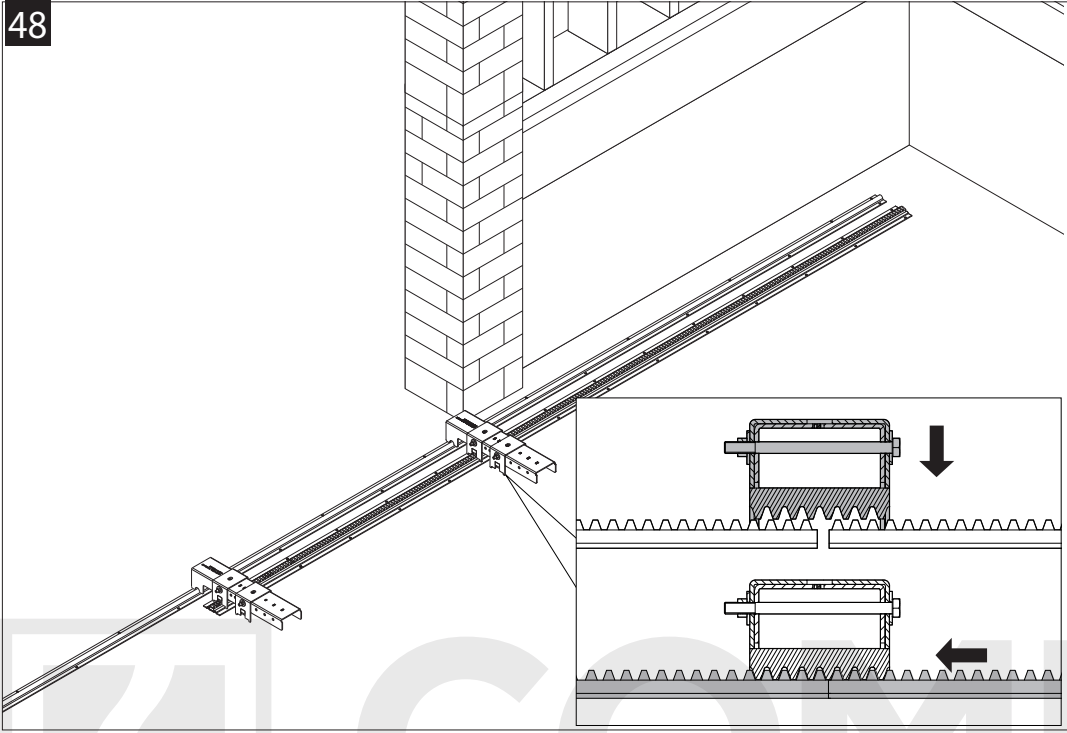

49

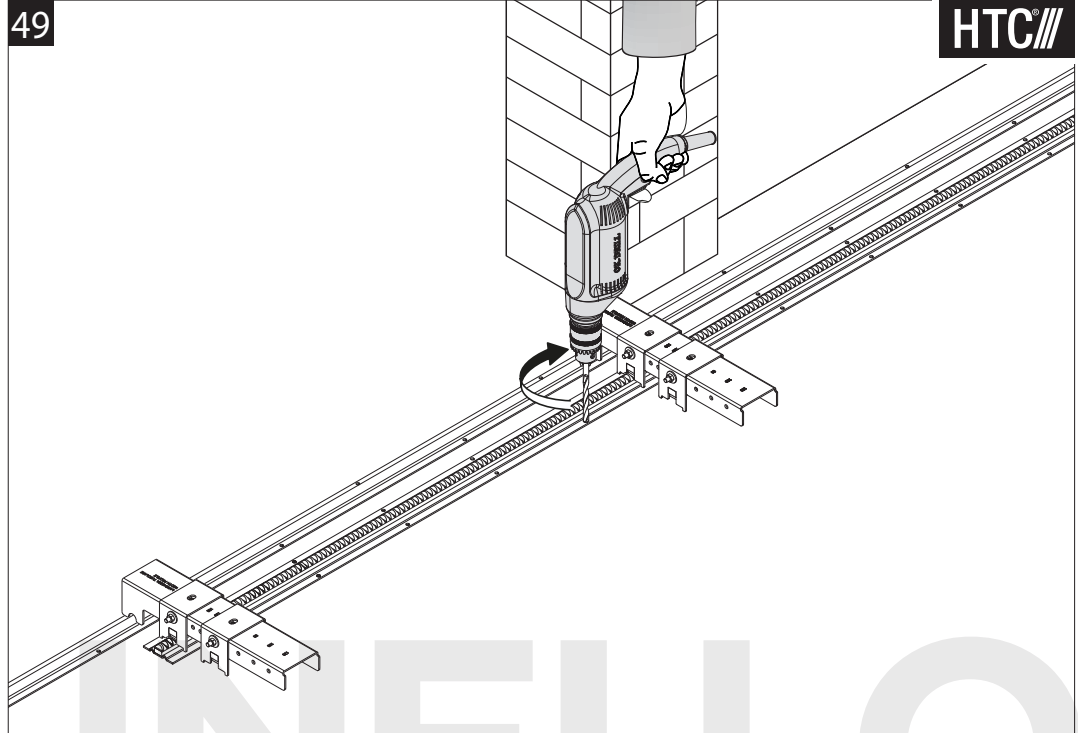

HTC

50

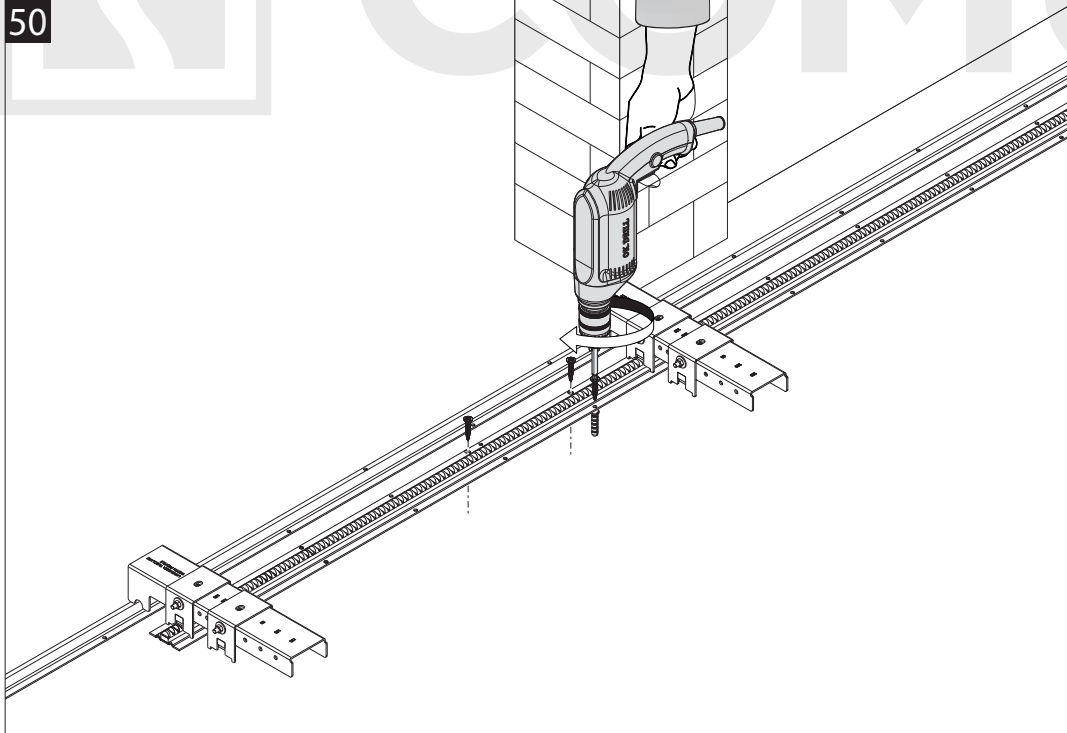

51

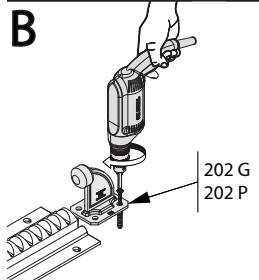
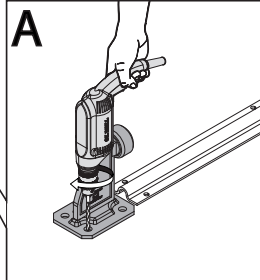
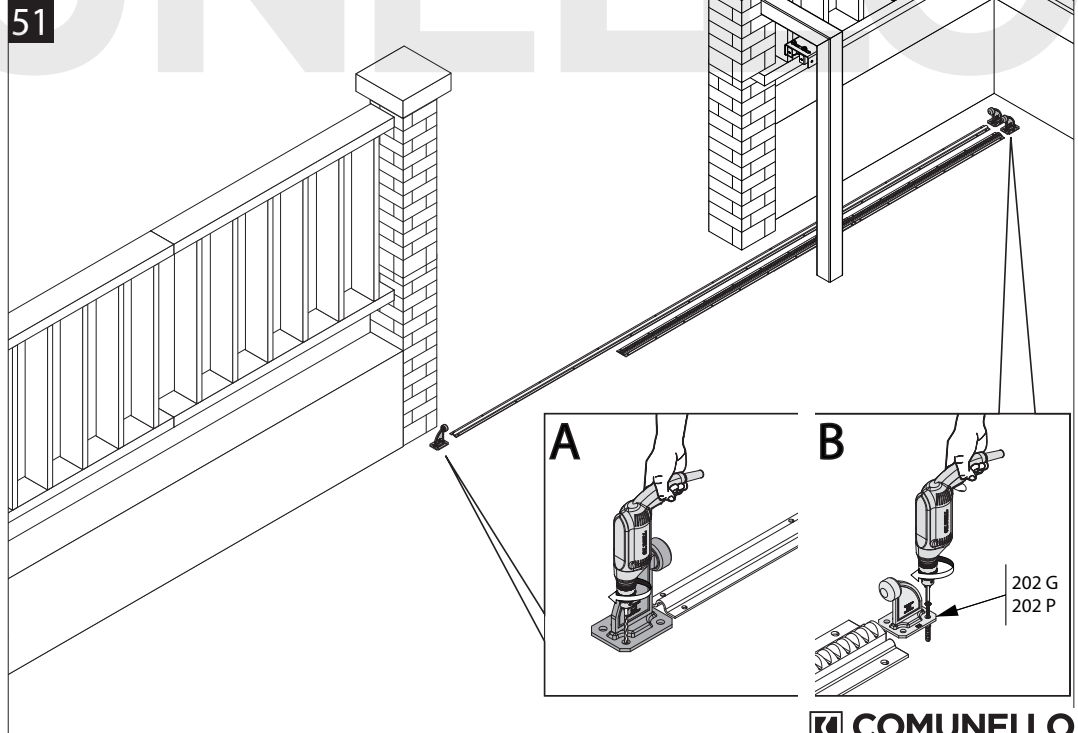

202 G
202 P

52

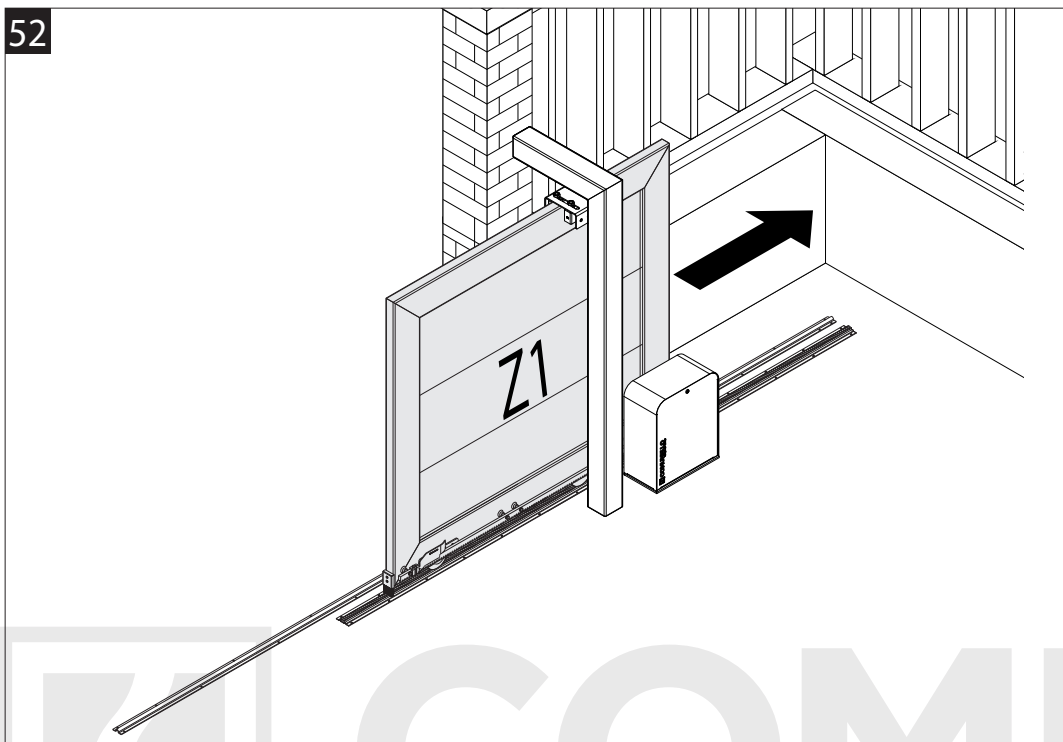

53

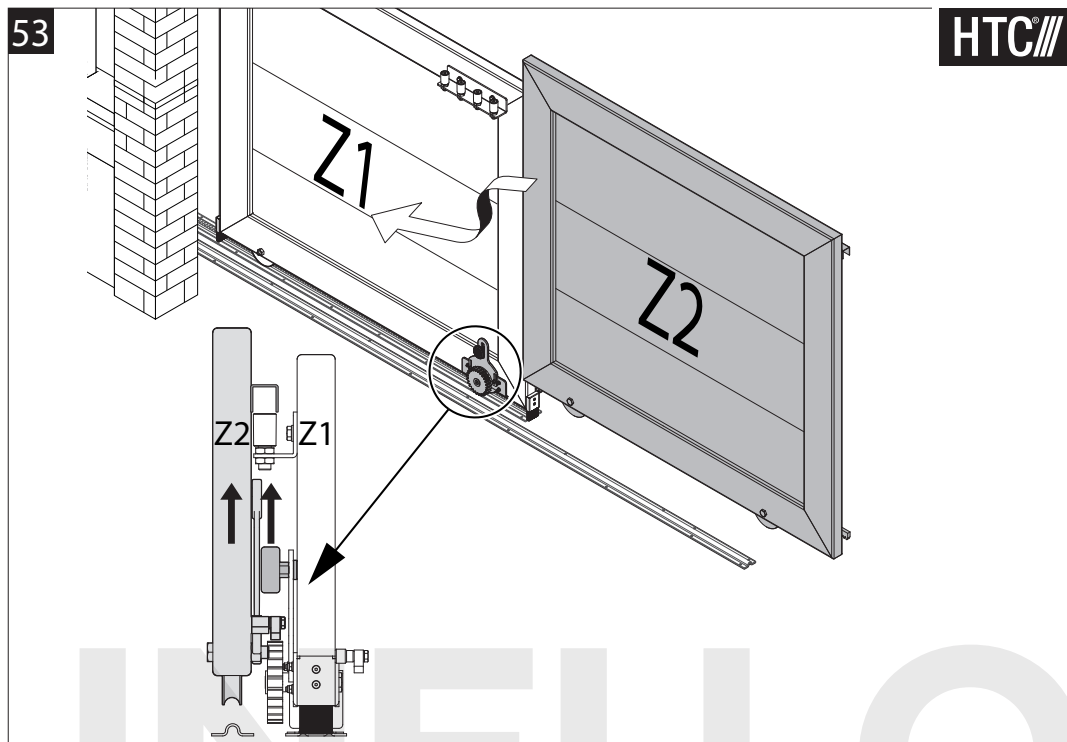

HTC

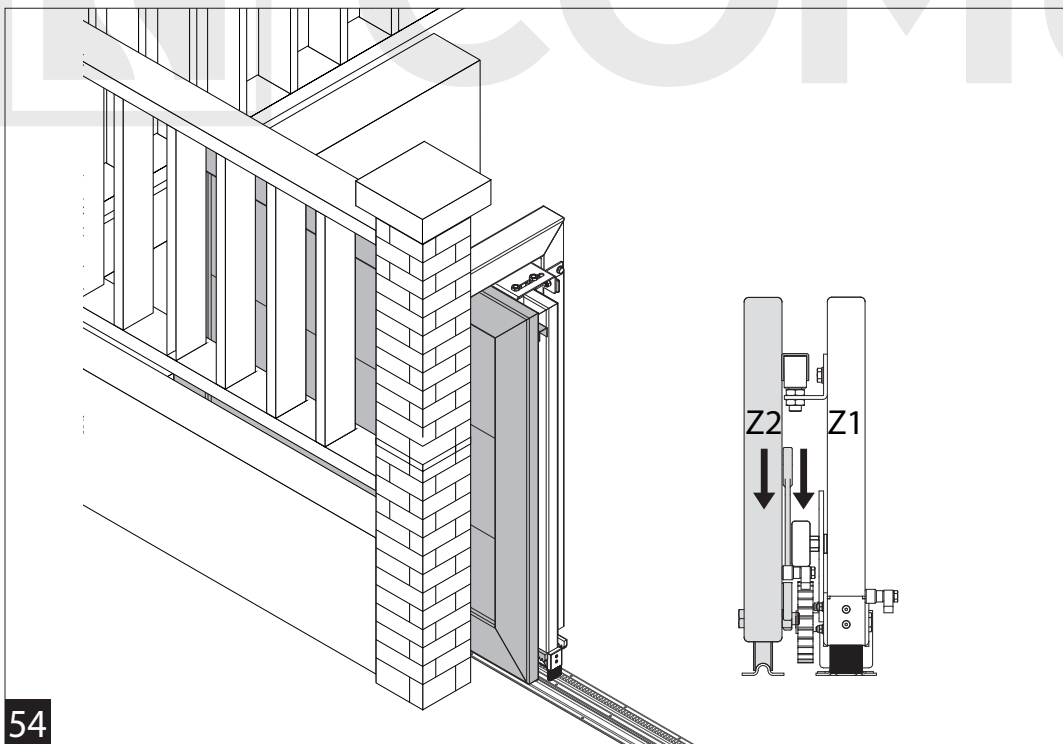

54

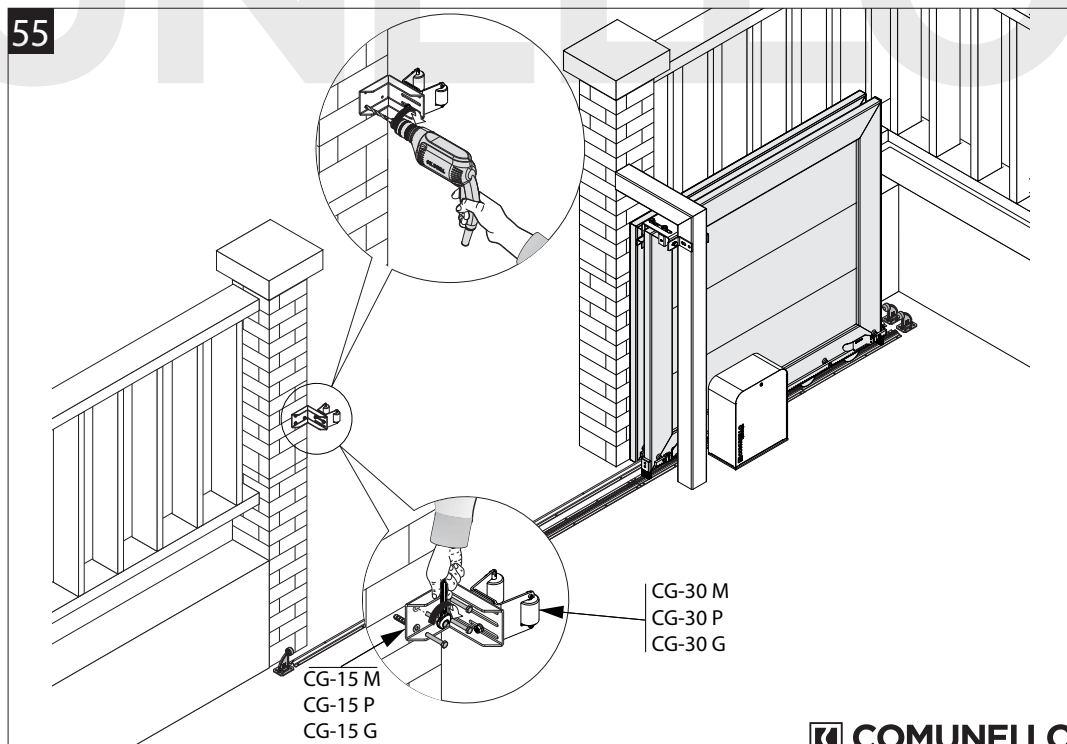

55